

Reliable®

Model EX Single Interlock Preaction Type A (LPCB)

2", 2-1/2", 76mm, 3", 4", 6", 165mm, & 8"

Features

- Redundant Solenoid Valve Release
- Externally Resettable Clapper
- One Main Drain

Product Description

Reliable Single Interlock Preaction Systems are designed for water-sensitive areas that require protection from inadvertent water flow into the sprinkler system piping. A single event, the activation of the electrical detection system, causes the valve to operate and flow water into the piping network.

Sprinkler piping in single interlock systems can effectively be supervised by means of the Reliable Model A Pressure Maintenance Device (provided) and a tank-mounted air compressor. Loss of supervising pneumatic pressure, due to a damaged sprinkler or sprinkler pipe will not cause water to flow through the Model EX Valve and into the system piping. A significant loss of pneumatic pressure will activate a trouble-annunciating device when the system pressure falls below a predetermined pressure level.

The system incorporates two normally closed solenoid valves on the releasing trim. These solenoid valves, when closed, retain sufficient AIR pressure on the pneumatic actuator, which in turn preserves sufficient WATER pressure in the push rod chamber of the Model EX Valve in order to maintain it closed. When the electrical detection system senses the presence of fire, the electrical releasing control panel activates fire alarm devices and energizes the two redundant, normally-closed solenoid valves into the open position.

Energizing the solenoid valves relieves the air pressure on the pneumatic actuator, thereby releasing the water pressure that it was retaining. This in turn relieves the pressure in the push rod chamber of the Model EX Valve. Venting the push rod chamber will open the Model EX Valve and allow water to flow into the sprinkler system.

Water flowing into the sprinkler system piping will simultaneously produce water pressure that causes the transfer of contacts in the pressure switch mounted in the trim. This pressure switch can

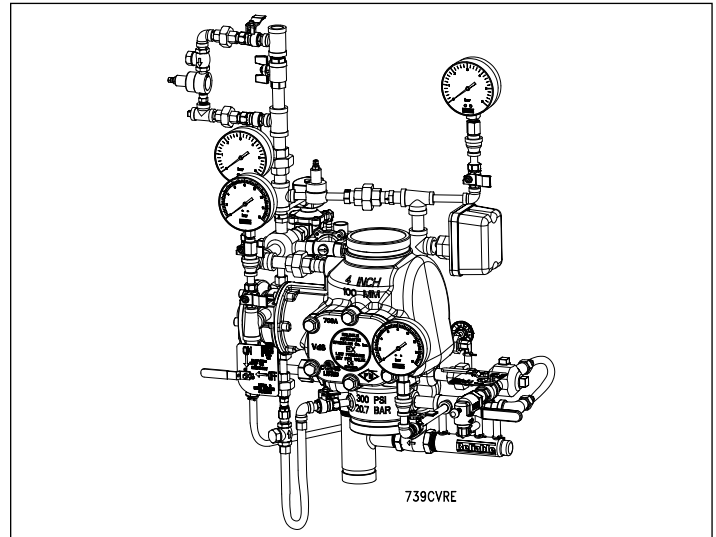

electrically initiate the shutdown or startup of equipment, such as computers or other second alarm devices. The flow of water into the sprinkler system piping effectively converts the dry system into a wet pipe system. In the event that the fire subsequently produces sufficient heat to operate a fire sprinkler, water will flow from that sprinkler, controlling or suppressing the fire.

The major benefits of a single interlock preaction system, when compared with a wet pipe (deluge) system are as follows:

1. A fire alarm sounds prior to the operation of a sprinkler, which may enable extinguishing the fire by handheld means before the actual operation of any sprinklers and subsequent water damage.
2. A trouble annunciator signals whenever the integrity of the piping or sprinklers is accidentally or intentionally disturbed; however, no water flow or water damage will occur at that time.
3. Speedy detection and an early fire alarm are provided by fire detectors, without the delay associated with water flow detection in the event of a fire. Note: with a wet pipe system, the fire alarm is delayed until after water has begun flowing from an operated sprinkler.

Table A

Valve Size	End Connection	Approx. Shipping Weight
2" (50mm), 2-1/2" (65mm), 76mm & 3" (80mm)	Groove/ Groove	44lbs (20kg)
	Groove/ Groove	
4" (100mm)	Flange/ Groove	74lbs (34kg)
	Flange/ Flange	
6" (150mm) & 165mm	Groove/ Groove	105lbs (48kg)
	Flange/ Groove	
8" (200mm)	Flange/ Flange	158lbs (72kg)
	Groove/Groove	
	Flange/Flange	

Model EX Single Interlock Preaction System Type A Technical Data

Technical Specifications

Pressure Rating:

175 psi (12,1 bar)

Minimum Water Supply Pressure:

20psi (1,4 bar)

Minimum Water Supply Temperature:

40°F (4°C)

Maximum Water Supply Temperature:

140°F (60°C)

Factory tested to hydrostatic pressure of 500 psi (34.5 bar)

Listings and Approvals

LPCB

End Connections

See Table A

Specifications

Groove: ANSI/AWWA C606

Flange: ASME B 16.5 or ISO 7005-2 PN16

Thread: ANSI B1.20.1

Model EX Type A Dimensions

Figure 1

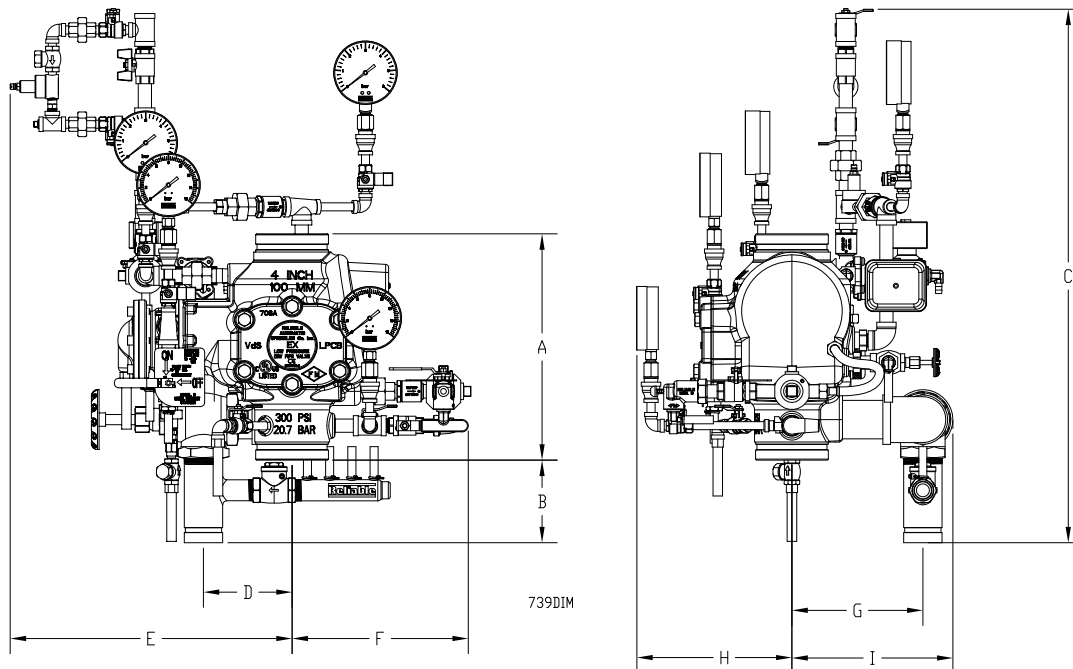

Installation Dimensions in Inches (mm)

Table B

Valve Size	End Connection	A ⁽¹⁾	A ⁽²⁾	B	C	D	E	F	G	H	I
2" (50mm)	Groove/Groove	12-1/2 (318)	NA	5-1/2 (140)	31-1/2 (800)	4-1/4 (108)	14-1/2 (368)	10-1/2 (267)	7 (178)	8-1/2 (216)	8-3/8 (213)
2-1/2" (65mm)			NA								
76mm			NA								
3" (80mm)			NA								
4" (100mm)	Groove/Groove	14 (356)	16 (406)	5-1/2 (130)	33-3/8 (848)	5-1/2 (140)	16 (406)	11-5/8 (295)	8 (203)	8-1/2 (216)	10 (254)
	Flange/Groove	16 (406)									
	Flange/Flange	16 (406)									
6" (150mm) & 165mm	Groove/Groove	16 (406)	19 (483)	4-7/8 (124)	34-5/8 (880)	5-1/2 (140)	16-1/2 (419)	12-1/4 (311)	8-5/8 (219)	8-1/2 (216)	10-1/2 (267)
	Flange/Groove	19 (483)									
	Flange/Flange	19 (483)									
8" (200mm)	Groove/Groove	19-3/8 (492)	21-1/4 (540)	4-5/8 (117)	34-1/8 (867)	5-1/2 (140)	17 (432)	14-1/4 (362)	9-1/8 (232)	8-1/2 (216)	11-3/4 (298)
	Flange/Flange	21-1/4 (540)									

Notes:

- End to end take out of Model DDX valve with grooved inlet.
- End to end take out of Model DDX valve with flanged inlet where available (see page 1, table A).

At the heart of Reliable's Single Interlock Preaction System is the Model EX Valve. This valve is a hydraulically operated, straight-through-design, differential-type valve (see Fig. 2). System maintenance is simplified since priming water is not required and the deluge valve can be reset externally without cover removal. This is accomplished by pushing in and turning the external reset knob at the rear of the valve (see Fig. 2). This feature provides a significant system-restoration time advantage.

The Reliable Single Interlock Preaction System trim set (see Fig. 2) provides all of the necessary equipment for connections to the valve's pushrod chamber inlet and outlet ports, the main drain, alarm devices, air supply, water supply, and required pressure gauges. This valve is provided fully assembled with trim.

System Operation

To fully operate a Reliable Single Interlock Preaction System, two independent events must coexist before water is discharged. One electrical detector (two detectors in a cross-zoned system) must activate and a sprinkler must open. Operation of the detection system will cause the valve to open, but no water will discharge since the sprinklers will not have opened. Opening of a sprinkler in the absence of a detection signal will result in loss of air or nitrogen pressure and activation of a low pressure alarm.

When set correctly for service, the Model EX Valve is hydraulically established to withhold the supply water from the sprinkler system piping. The Reliable Model EX Valve is shown in both closed and open positions in Fig.2. In the closed position, the supply pressure acts on the underside of the clapper and also on the push rod through the push rod chamber's inlet restriction. The resultant force due to the supply pressure acting on the push rod is multiplied by the mechanical advantage of the lever and is more than sufficient to hold the clapper closed against normal supply pressure surges.

When a fire is detected, the energized solenoid valves vent the air from the pneumatic actuator, which in turn vents the push rod chamber to atmosphere through the chamber's outlet. Since the pressure cannot be replenished through the inlet restriction as rapidly as it is vented, the pushrod chamber pressure falls instantaneously. When the pushrod chamber pressure approaches approximately one-third of the supply pressure, the upward force of the supply pressure acting beneath the clapper overcomes the lever-applied force thereby opening the clapper.

Once the clapper has opened, the lever acts as a latch, preventing the clapper from returning to the closed position. Water from the supply flows through the EX Valve into the system piping. Water also flows through the dry pipe alarm outlet to the alarm devices.

After the system is shut down and drained, the Model EX valve can be reset by pushing in and turning the reset knob at the rear of the valve (see Fig.2). The external reset feature of the Model EX Valve provides a means for simple, economical system testing, which is one essential facet of a good maintenance program.

The external reset feature does not, however, eliminate another important facet of good maintenance, namely, periodic cleaning and inspection of the internal valve parts. In the event that water builds up inside the valve due to condensate from the air supply system or water left inside from valve system testing, a drain is available for venting. After closing the main supply valve, a small valve over the drain cup can be opened slightly until the water inside the valve body and the main pipe column has drained. See the section titled "Draining Excess/Condensate Water From System" in this bulletin for the detailed procedure.

The Model B Manual Emergency Station is also included in the trim set. It consists of an aluminum nameplate mechanically attached to a ball valve. The valve handle in its OFF position is guarded against accidental turning to the ON position (and system discharge) by a nylon cable tie provided with each trim kit. The cable tie is inserted, after the system has been restored for operation. The nylon cable tie is designed to allow, in case of an emergency, forceful turning of the valve handle to the ON position. As an alternative to the Model B Hydraulic Manual Emergency Station, the Model A Hydraulic Manual Emergency Pull Box (see Reliable Bulletin 506) is also available and can be provided as an option.

Whenever ambient temperature conditions are high, the water temperature in the Model EX Valve's pushrod chamber could possibly increase, thereby increasing the pressure in the chamber to values exceeding the rated pressure of the system. In an installation where standard temperatures are exceeded, a pressure relief kit may be needed. Pressure relief kit, P/N 6503050001, can be installed into the pushrod chamber's releasing line to limit the pressure to 175 psi (12,1 bar).

Model EX Type A Section and Rear Views

Figure 2

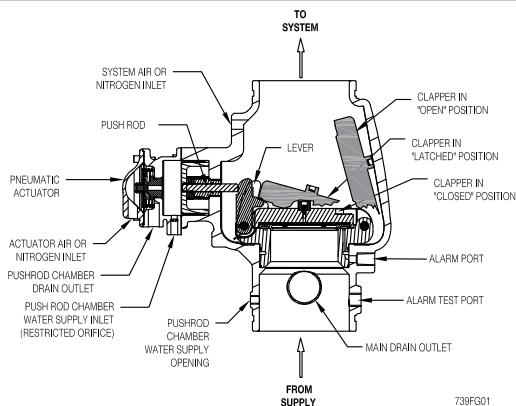

SECTION VIEW OF MODEL EX VALVE WITH CLAPPER IN OPEN, CLOSED, AND LATCHED POSITIONS

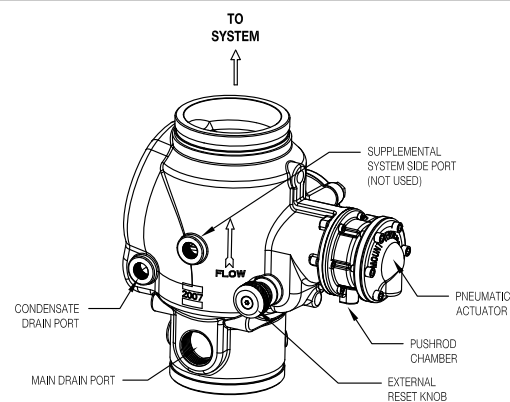

PUSH INWARD AND ROTATE EXTERNAL RESET KNOB CLOCKWISE (WHEN VIEWED FROM REAR) TO RESET CLAPPER. RESET KNOB CAN ONLY BE OPERATED WHEN PUSH-ROD CHAMBER IS FULLY VENTED (0 PSIG)

REAR VIEW OF MODEL EX VALVE

System Design Considerations

The automatic sprinklers, air compressor, releasing devices, electric releasing control equipment, fire detection devices, manual pull stations, and signaling devices which are utilized with this Reliable Single Interlock Preaction System must be Loss Prevention Certification Board (LPCB) approved, as applicable.

The system valve and all interconnecting piping must be located in a readily visible and accessible location and in an area that can be maintained at a minimum temperature of 40°F (4°C). **Note:** Heat tracing is not permitted.

The redundant solenoid valves are operated and supervised by an electrical releasing/control panel.

System Air Pressure Requirements

When a Reliable Single Interlock Preaction System is utilized, the sprinkler system piping requires a minimum of 7 psi (0,5 bar) supervisory pneumatic pressure. The Model A Pressure Maintenance Device, along with an additional air pressure regulator, are used to maintain the system pneumatic pressure between 7 and 10 psi (0,5 and 0,7 bar) where a dry nitrogen gas supply or a clean, dependable, and continuous (24 hours per day, 7 days per week) compressed air source is available.

The section of the preaction trim that contains the two redundant normally-closed solenoid valves, and the supply to the pneumatic actuator require pneumatic pressure settings per Table C. When establishing the preaction system for service, refer to Table C of this bulletin for the correct pneumatic pressure settings for a corresponding water supply pressure.

Note: During the initial system set-up, a higher pneumatic pressure may be required in order to properly seat the internal diaphragm of the pneumatic actuator.

Refer to Reliable Bulletin 251 for instructions on how to modify these pressure settings.

System Pressure

Table C

Water Pressure psi (bar)	Pneumatic Pressure to be Pumped into Sprinkler System, psi (bar)
Maximum	Minimum
20 (1.4)	8 (0.6)
30 (2.1)	10 (0.7)
50 (3.4)	12 (0.8)
75 (5.2)	13 (0.9)
100 (6.9)	15 (1.0)
125 (8.6)	16 (1.1)
150 (10.3)	17 (1.2)
175 (12.1)	18 (1.2)

Notes:

- Supervisory air or nitrogen pressure should not exceed 30 psi (2.1 bar). Excess pressure may result in damage to the actuator.
- Fastest valve operation is achieved with lower supervisory air or nitrogen pressure; however, the supervisory air or nitrogen pressure must be at least the minimum specified in Table F.

System Electrical Requirements

All releasing, alarm and detection devices in this Reliable Single Interlock Preaction System are supervised by the Preaction Panel Series 1000 MK4. The power supply, the standby emergency power supply, battery charger, and the rectifier circuitry are all contained within this panel. For additional and detailed wiring information, refer to the manufacturer's literature included with the Releasing Control Panel.

Note: In order for the solenoid valve to maintain Reliable warranty it must remain sealed as it came from the factory. If there are concerns about the valve's internal components, immediate replacement is recommended.

Friction Loss

Table D

Valve Size:	Equivalent Length:		Cv
	C = 120	C = 100	
2" (50mm)	4.4 ft (1,3 m)	3.1 ft (1,0 m)	101
2-1/2" (65mm)	6.0 ft (1,8 m)	4.3 ft (1,3 m)	236
76mm	7.7 ft (2,3 m)	5.5 ft (1,7 m)	241
3" (80mm)	12.6 ft (3,8 m)	9.0 ft (2,7 m)	254
4" (100mm)	14 ft (4,3 m)	10 ft (3,0 m)	469
165mm	29.4 ft (9,0 m)	20.9 ft (6,4 m)	886
6" (150mm)	29.4 ft (9,0 m)	20.9 ft (6,4 m)	886
8" (200mm)	53.5 ft (16,3 m)	38.1 ft (11,6 m)	1516

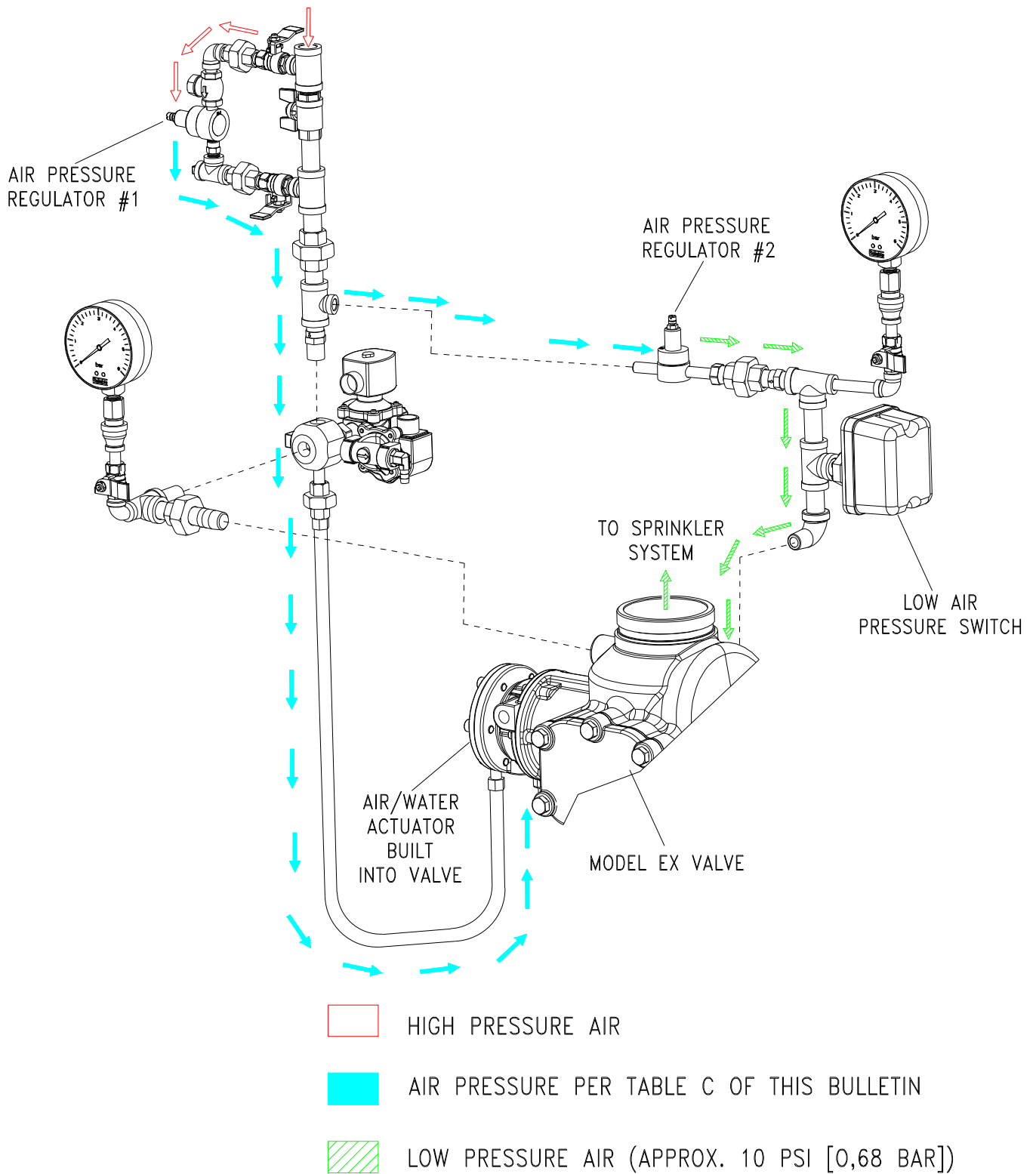

739FG04D

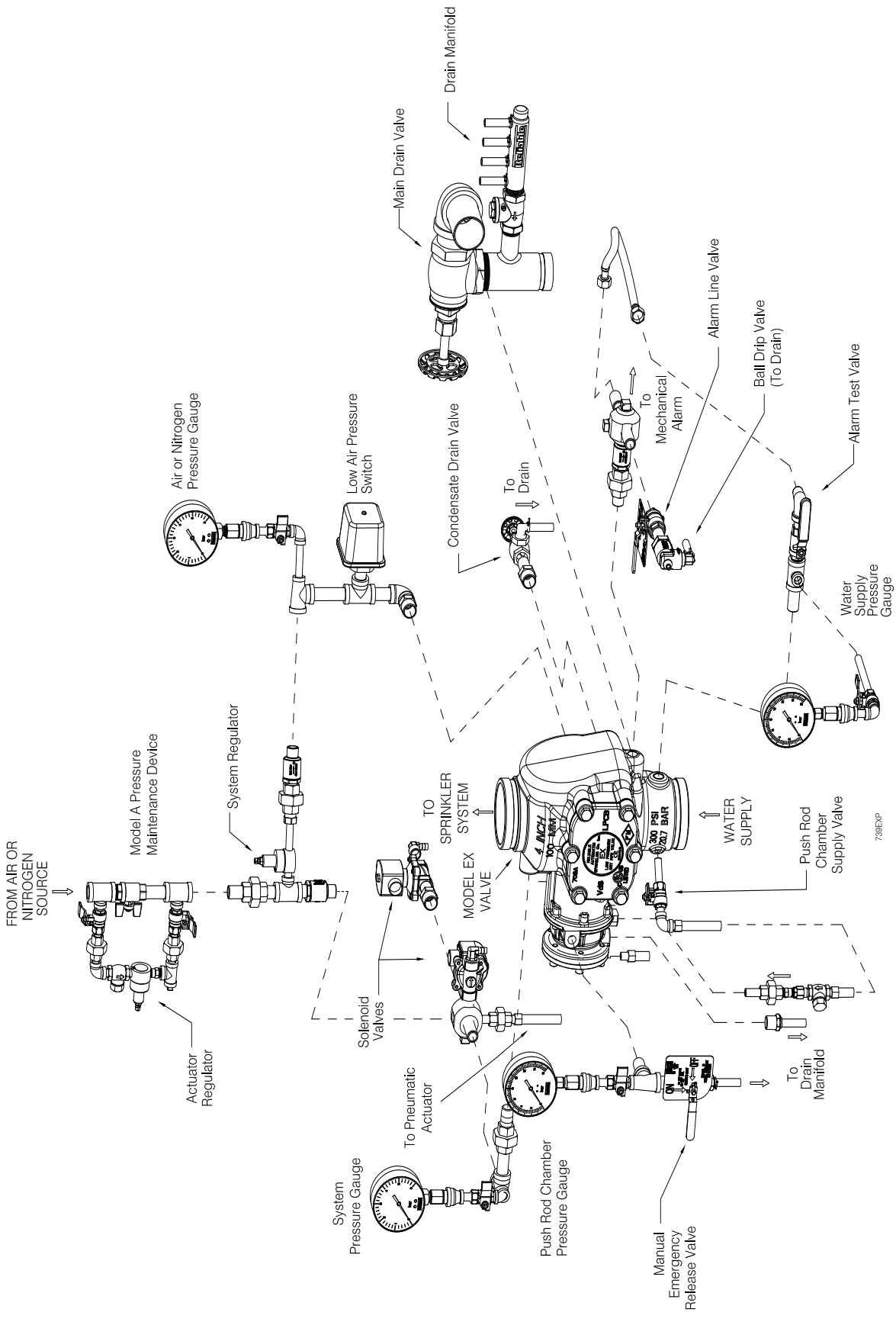

Resetting the Model EX Single Interlock System (Ref. Fig. 5)

1. Close the valve controlling water supply to the Model EX Valve and close the air or nitrogen supply to the sprinkler system.
2. Close the pushrod chamber supply valve.
3. Open main drain valve and drain system. Close main drain valve.
4. Open all drain valves and vents at low points throughout the system, closing them when flow of water has stopped.
5. Open the Manual Emergency Station to relieve pressure in the pushrod chamber of the Model EX Valve.
6. With the alarm line valve open, push in the plunger of ball drip valve, forcing the ball from its seat, and drain the alarm line. Close the alarm line valve.
7. With the Manual Emergency Station open, push in and rotate the Model EX Valve external reset knob counterclockwise (when facing the valve), until you hear a distinct noise indicating that the clapper has reset. Note: The reset knob can be rotated only while pressure in the pushrod chamber is vented to atmospheric condition (0 psig) in step 5.
8. Inspect and replace any portion of the detection system and/or sprinkler system subjected to fire conditions.
9. Confirm that solenoid valves are de-energized and closed.
10. Open the air or nitrogen supply quick fill valve to restore supervisory pressure in the sprinkler system and close the pneumatic actuator. Allow the pressure to build to the level specified in Table A, then set the pneumatic supply to automatic operation.
11. Open the main drain approximately two turns.
12. Open the pushrod chamber supply valve.
13. Slightly open the main control valve until water can just be heard running out the main drain.
14. Slowly close the main drain, directing water to the Manual Emergency Release. Allow water to flow through the Manual Emergency release to purge air from the pushrod chamber. Note: Venting of air from the pushrod chamber is very important to ensure proper system operation and avoid false tripping of the Model EX Valve.
15. Upon seeing a solid flow of water from the drain tubing, close the Manual Emergency Release valve. Allow pressure to build below the Model EX Valve clapper.
16. Open the alarm line valve. If no leak occurs, the Model EX Valve clapper is sealed.
17. Slowly open the main valve controlling water supply until fully open and verify that it is properly monitored.
18. Verify that the pushrod chamber supply valve and alarm line valve are open. The pushrod chamber supply valve must remain open when the Model EX Valve has been reset to maintain water pressure in the pushrod chamber.
19. Verify that the Manual Emergency Station is secured in the OFF position with the appropriate nylon tie.

Inspection and Testing

1. Water supply — Confirm that valves controlling water supply to the EX Valve are opened fully and properly monitored.
2. Alarm line — Confirm that the alarm line valve is open and remains in this position.
3. Other trim valves — Confirm that the pushrod chamber supply valve is open, as well as all pressure gauge valves. The main drain valve, condensate drain valve, and alarm test valve should be closed.
4. Ball drip valve — Push in on the plunger to be sure ball check is off its seat. If no water appears, the Model EX Valve water seat is tight. Inspect the bleed hole on the underside of the pushrod chamber for leakage.
5. Supervisory pneumatic pressure — Inspect actuation piping and system air (or nitrogen) pressure for conformance to Table A.
6. Releasing device — Check outlet of the releasing devices (i.e., hydraulic manual emergency station and solenoids) for leakage. Also verify that tubing drain lines from releasing devices are not pinched or crushed which could prevent proper releasing of the EX Valve.
7. Testing alarms — Open the alarm test valve permitting water from the supply to flow to the electric sprinkler alarm switch and to the mechanical sprinkler alarm (water motor). After testing, close this valve securely. Push in on the plunger of ball drip valve until all water has drained from the alarm line.
8. Operational test — Open the Model B Manual Emergency Station. Alternatively, deplete pneumatic pressure from the sprinkler system. **Note: AN OPERATIONAL TEST WILL CAUSE THE MODEL EX VALVE TO OPEN AND FLOW WATER INTO THE SPRINKLER SYSTEM.**
9. Secure the Model B Manual Emergency Station in the OFF position with nylon tie after EX Valve is reset.

Testing Detection System Without Operating Model EX Valve

1. Close the valve controlling water supply to the system valve and open the main drain valve.
2. Verify that valve supplying hydraulic pressure to the piston/pushrod chamber is open, allowing water to enter the pushrod chamber.
3. Deplete pneumatic pressure from the sprinkler system.
4. Loss of pneumatic pressure must result in a sudden drop of water pressure in the pushrod chamber, as indicated by the pressure gauge on the hydraulic release trim.
5. Reset the valve per the reset instructions.

Maintenance

The owner is responsible for maintaining the fire protection system in proper operating condition. Any system maintenance or testing that involves placing a control valve or detection/control system out of service may eliminate the fire protection that is provided by the fire protection system.

The Reliable Model EX valve and associated equipment shall periodically be given a thorough inspection and test. NFPA 25, "Inspection, Testing, and Maintenance of Water Based Fire Protection Systems," provides minimum maintenance requirements. System components shall be tested, operated, cleaned, and inspected at least annually, and parts replaced as required. Replace any components found to be corroded, damaged, worn, or non-operable. Increase the frequency of inspections when the valve is exposed to corrosive conditions or chemicals that could impact materials or operation of the assembly.

If face plate is removed during maintenance, torque face plate bolts to the following values during re-installation:

- 35 ft-lbs. (47 N-m) for 2" through 4" valves
- 70 ft-lbs. (95 N-m) for 6"-8" valves

Draining Excess/Condensate Water from the System

1. Notify the owner and monitoring company that maintenance is being performed on the system.
2. Close the main water control valve.
3. Open the Main Drain Valve.
4. Open the Condensate Drain Valve until all water has drained.
5. Close Condensate Drain Valve.
6. Partially open the Main Water Control Valve.
7. Slowly close the Main Drain Valve.
8. Fully open the Main Water Control Valve.
9. Notify the owner and monitoring company that the system has been returned to service.

Clapper Gasket and Seat Replacement Procedure

1. Disable detection system and supervisory pneumatic supply to system.
2. Shut down the valve controlling the water supply to the system and open the main drain valve. Open the condensate drain valve. Close the pushrod chamber supply valve and open the Model B Manual Emergency Station.
3. Remove the EX Valve front (handhold) cover and inspect the seat, clapper, and seal assembly for damage. If inspection indicates damage to the seal assembly only, replace as follows:
4. Remove the bumpstop nuts and remove the seal assembly. Install a new seal assembly and thread the bumpstop nuts onto the threaded studs of the seal assembly. Tighten finger tight plus ¼ to ½ turn.
5. If inspection indicates damage to the clapper, proceed to step 6.

6. At the rear of the valve, disconnect the condensate drain trim section starting with the elbow connector. Then remove the ¼" globe valve, followed by the ¾"x¼" reducing bushing. Remove the retaining rings from the clapper hinge pin, push the hinge through the condensate drain opening and remove the clapper subassembly. Install a new clapper subassembly in the reverse order making sure the clapper spacers are in their proper position.
7. If the seat is damaged, or it is suspected that the leakage is through the seat O-rings, proceed to step 8.
8. Using Reliable P/N 6881603000 Seat Wrench for 2" (50mm), 2½" (65mm), 76mm and 3" (80mm) valve sizes, Reliable P/N 6881604000 for 4" (100mm) valve size, Reliable P/N 6881606000 for the 6" (150mm) and 165mm valve sizes or Reliable P/N 6881608000 Seat Wrench for 8" (200mm) valve size, remove the seat by unscrewing. This will loosen the seat-clapper-mounting ring subassembly.

Solenoid Valve

WARNING: The owner is responsible for maintaining the fire protection system in proper operating condition. Any system maintenance or testing that involves placing a control valve or detection system out of service may eliminate the fire protection of that system. Prior to proceeding, notify all authorities having jurisdiction. Consideration should be given to employment of a fire patrol in the affected area.

WARNING: Prior to operating the solenoid valve, be sure to close the system control valve to avoid unintentional operation of the system.

1. Inspections: It is imperative that the system be inspected and tested in accordance with NFPA 25 on a regular basis. The frequency of the inspections may vary due to contaminated water supplies, corrosive water supplies, or corrosive atmospheres. In addition, the alarm devices, detection systems, or other connected trim may require a more frequent schedule. Refer to the system description and applicable codes for minimum requirements.
2. The valve must be inspected at least monthly for cracks, corrosion, leakage, etc., cleaned and replaced as necessary.
3. If leakage is suspected through the solenoid valve, it should be replaced.

Troubleshooting

1. **Mechanical sprinkler alarm not operating:** This is most likely caused by a clogged screen in the strainer of the water motor. Proceed as follows: Remove plug from the strainer. Remove and clean the screen. Replace the screen and the plug, and then tighten securely (Ref. Bulletin 613).
2. **Water leaking from Ball Drip.** This can be caused by either a water column on top of the clapper or a supply water leakage.
 - a. **Leakage due to water column.** This condition is caused by leakage past the clapper seal assembly. Be sure the clapper seal and seat are free of any type of debris or damage. If necessary, follow steps below to replace the seal assembly and/or seat.
 - b. **Supply water leakage.** This condition is caused by leakage past the lower seat O-ring. Follow steps below for inspection and/or replacement of lower seat O-ring.
3. **Air or nitrogen leaking from Ball Drip.** This condition is caused by leakage past either the clapper seal assembly or the upper seat O-ring.
 - a. **Clapper seal leak.** Be sure the clapper seal and seat are free of any type of debris or damage. If necessary, follow steps below to replace the seal assembly and/or seat.
 - b. **Upper seat O-ring.** Follow steps below for inspection and/or replacement of upper seat O-ring.

Clapper Gasket and Seat Replacement Procedure (cont.)

- 8 (cont). Reach into the valve and grasp the seat and remove it from the valve. Then remove the clapper-mounting ring subassembly from the valve. Visually examine all components of the seat-clapper-mounting ring subassembly replacing any component that appears damaged. New O-rings should always be used for reassembly.
9. Reassembly: clean the bore of the valve body. Lubricate the bore with O-ring grease. Lubricate and install the O-rings onto the seat. Lubricate and install the mounting ring O-ring into the body (8" (200mm) valve size only). Insert the clapper-mounting ring subassembly into the handhold opening of the EX Valve using caution to not damage or dislodge the mounting ring O-ring (8" (200mm) valve size only). Align the mounting ring so that the Lever is near the pushrod and the mounting ring "ears" are between the tabs of the valve body. Insert the seat into the valve body and through the clapper-mounting ring subassembly. Start to tread the seat into the body by hand, then tighten the seat with the seat wrench until it bottoms out on the mounting ring. Verify that the seat-clapper-mounting ring subassembly is in the fully down position between the tabs of the body, and check to see that the lever lines up with the pushrod. Reassemble the handhold cover and set up the Model EX Valve as per the section "Resetting Model EX Valve Single Interlock Preaction Systems".

Pushrod Chamber Diaphragm and O-Ring Replacement Procedure

A small bleed hole is located on the underside of the pushrod chamber. If there is air or water leakage coming out of the bleed hole:

- a. Disable detection system and supervisory pneumatic supply to system.
- b. Shut down the valve controlling water supply to the system. Relieve the inlet pressure by opening the main drain valve. Close the valve that supplies water to the pushrod chamber, and open the Model B Manual Emergency Station.
- c. Remove the trim at the unions nearest to the pushrod chamber cover.
- d. Take the pushrod chamber cover off by removing the six retaining screws.

CONDITION ONE (Water coming out of the bleed hole):

Water coming out of the bleed hole is caused by a leaking diaphragm. Visually inspect the pushrod chamber cover and piston to determine what could have damaged the diaphragm and then correct. Install a new diaphragm. **NOTE: The diaphragm has two different surfaces; it is not bi-directional.** It will fail if installed backwards! Roll the diaphragm so that the smooth surface (the pressure side) conforms to the inside of the pushrod chamber cover and the fabric side engages the pushrod, and reassemble the six retaining screws with an installation torque of 15 foot-pounds in a star pattern. Set up the Model EX Valve as per the section "Resetting Model EX Valve Single Interlock Preaction Systems".

CONDITION TWO (System Air coming out of the bleed hole):

System air coming out of the bleed hole is caused by a worn O-ring assembled to the pushrod guide. Remove the piston-pushrod subassembly, pushrod spring, and pushrod guide. Installation torque for the pushrod guide is 35 inch-pounds. **CAUTION: Do not over tighten the pushrod guide.** Reassemble the components that were initially removed. Re-install the diaphragm if it appears to be in good shape, otherwise, replace it also. **NOTE: The diaphragm has two different surfaces; it is not bi-directional. It will fail if installed backwards!** Roll the diaphragm so that the smooth surface (the pressure side) conforms to the inside of the pushrod chamber cover and the fabric side engages the pushrod, and reassemble the six retaining screws with an installation torque of 15 foot-pounds in a star pattern. Set up the Model EX Valve as per the section "Resetting Model EX Valve Single Interlock Preaction Systems".

Listing & Approvals

The LPCB approval for Single Interlock Preaction systems states the system must comply with the general requirements of the "LPC Rules for Automatic Sprinkler Systems (incorporating EN12845)" and in particular Technical Bulletin 208 "Supplementary requirements for sprinkler installations which can operate in the dry mode".

Loss Prevention Certification Board (LPCB)

Installation Requirements of Preaction Systems Include:

1. The equipment must be installed, configured and maintained in accordance with the manufacturers specifications, by appropriately trained personnel.
2. The system shall be electrically monitored and be capable of indicating "ready to operate" at all times.
3. Detectors should be LPCB approved and must be compatible with the Control Panel.
4. Connecting cables shall comply with BS6387 (classification C, W, Z).
5. Two LPCB approved Solenoid Valves shall be installed in parallel, shall function in the pneumatic condition only and be protected by a strainer.
6. Clean dry air (or Nitrogen) shall be used. An air maintenance device shall be used, such that the inflow of air cannot exceed the egress of air through one sprinkler, or any other means of operating the valve.

Ordering Information

Specify:

Model EX Single Interlock Preaction System Type A

- Size
 - 2" (50mm)
 - 2-1/2" (65mm)
 - 3" (80mm)
 - 76mm
 - 4" (100mm)
 - 6" (150mm)
 - 165mm
 - 8" (200mm)
- End Configuration
 - See Table A

Service Kits

Service kits are available for routine servicing of the valve (reference assembly drawings on website). Service kits for the Model EX Single Interlock Preaction Type A valve include the following components:

- Clapper Seal Assembly (item 8)
- Cover Gasket (item 9)
- Bumpstop(s) (item 10)
- Push rod chamber diaphragm (item 18)
- Pneumatic Actuator Diaphragm Assembly (items 41, 42, 43, and 44)
- Grease (item 50)

2", 2-1/2", & 3" Model EX Service Kit: PN 6501200R09

4" Model EX Service Kit: PN 6501200R10

6" Model EX Service Kit: PN 6501200R11

8" Model EX Service Kit: PN 6501200R12