

Reliable®

Model FCA2 Floor Control Assembly

cULus Listed, FM Approved

Features

- Compact, light weight design
- Schedule 10 welded body (2" through 8")
- Schedule 40 welded body (1-1/4" and 1-1/2")
- Approved for vertical or horizontal installation
- Grooved components enable universal application

Product Description

The Model FCA2 Floor Control Assembly arrives from the factory as an assembled unit complete with butterfly valve, check valve, water flow switch, pressure gauge, and main drain as a cost-effective system riser or floor control assembly. The modular design allows all components to be independently rotated for maximum flexibility in design and installation, and the unique 90 degree orientation of the main drain and pressure gauge permits the Model FCA2 to be installed compactly in corners.

The Model FCA2 is cULus Listed (VEOY.EX5980) in all sizes and FM Approved (Standard 1626) in 2 in. to 8 in. (50 mm to 200 mm) sizes.. The main drain is available with a ball valve or Reliable TD (Test and Drain) valve available with a wide selection of test orifice K-factor choices. An optional pressure relief kit with adjustable pressure relief valve (175 - 310 psi [12.1 - 21.4 bar]) is also available.

Note: The adjustable pressure relief valve is UL Listed only and not FM Approved.



Representative Photograph (subject to change)

Model FCA2 Floor Control Assembly

Table A

Valve Size	Pressure Rating	Equivalent Length of Schedule 40 Pipe at C = 120	Material	Drain Size	K-Factor for Optional Test and Drain Valve*
1-1/4 (30mm)	300 psi (20.7 bar)	12.8	Schedule 40 Steel	1" (25mm)	2.8 (40)
1-1/2 (40mm)	300 psi (20.7 bar)	13.3	Schedule 40 Steel	1" (25mm)	4.2 (60)
2" (50mm)	300 psi (20.7 bar)	18.7	Schedule 10 Steel	1" (25mm)	5.6 (80)
2-1/2" (65mm)	250 psi (17.2 bar)	15.7	Schedule 10 Steel	1-1/4" (30mm)	2.8 (40)
3" (80mm)	250 psi (17.2 bar)	15.7	Schedule 10 Steel	1-1/4" (30mm)	4.2 (60)
					5.6 (80)
4" (100mm)	250 psi (17.2 bar)	18.8	Schedule 10 Steel	2" (50mm)	8.0 (115)
					11.2 (160)
					16.8 (240)
6" (150mm)	175 psi (12.0 bar)	27.2	Schedule 10 Steel	2" (50mm)	2.8 (40)
8" (200mm)	175 psi (12.0 bar)	26.8	Schedule 10 Steel	2" (50mm)	4.2 (60)
					5.6 (80)
					8.0 (115), 11.2 (160)

***Note:** K-factor must be equal to or less than the K-factor of the smallest K-factor installed on the sprinkler system. For sprinkler systems where the smallest K-factor sprinkler on the system is greater than the largest available valve K-factor, use any valve K-factor that will provide a minimum flow of 10gpm (38 lpm) as required to operate a UL Listed Waterflow Switch.

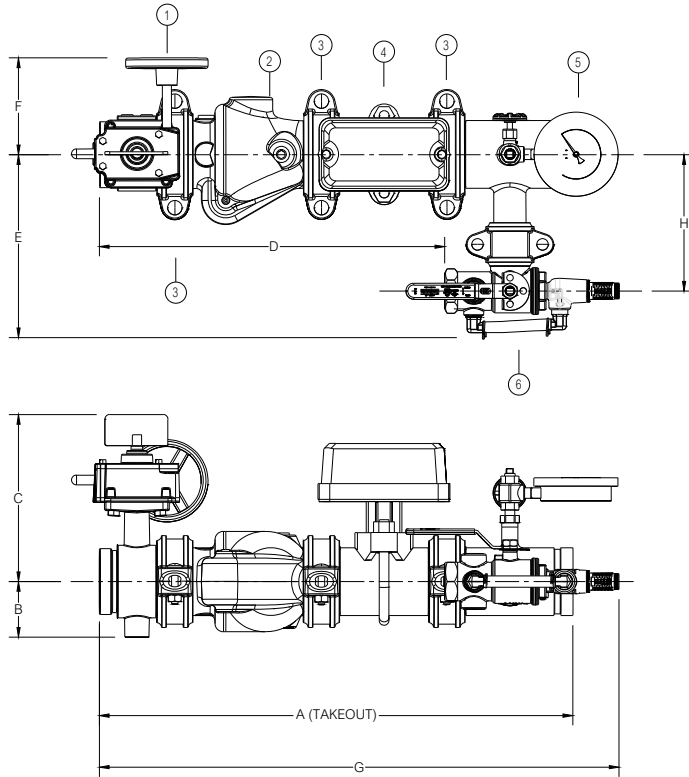

Legend	
Item	Description
1	Control Valve
2	Check Valve
3	Grooved Coupling
4	Water Flow Indicator
5	Pressure Gauge
6	Test and Drain Valve

Size	A	B	C	D	E	F	G	H	Weight (approx.)
1-1/4" (30mm)	23-1/4" (587mm)	1-3/4" (44mm)	6-1/2" (165mm)	16-1/2" (419mm)	6-7/8" (175mm)	2-1/4" (57mm)	25-3/8" (645mm)	4-3/4" (121mm)	19 lbs (8.6 kg)
1-1/2" (50mm)	23-1/4" (590mm)	1-3/4" (44mm)	6-1/2" (165mm)	16-3/4" (425mm)	7" (178mm)	2-3/8" (60mm)	25-5/8" (651mm)	4-3/4" (121mm)	23 lbs (10.4 kg)
2" (50mm)	23-5/8" (616mm)	2" (51mm)	7-1/2" (191mm)	17" (432mm)	7" (178mm)	5" (127mm)	25-3/4" (645mm)	5-3/4" (146mm)	30 lbs (13.6 kg)
2-1/2" (65mm)	24" (610)	2-5/8" (67mm)	8-1/4" (210mm)	17-3/8" (441mm)	9" (229mm)	5" (127mm)	26-3/8" (670mm)	6-3/4" (171mm)	42 lbs (19.1 kg)
3" (76mm)	24-1/2" (620mm)	2-7/8" (73mm)	8-5/8" (219mm)	17-3/4" (451mm)	9-1/4" (248mm)	5" (127mm)	26-7/8" (683mm)	7-1/8" (181mm)	49 lbs (22.3 kg)
4" (100mm)	26" (660mm)	3-3/4" (95mm)	9-3/4" (248mm)	18-3/4" (476mm)	10-3/4" (273mm)	5" (127mm)	29-1/4" (743mm)	8-1/8" (206mm)	65 lbs (29.5 kg)
6" (150mm)	29" (735mm)	4-3/4" (121mm)	11" (279mm)	21-3/4" (552mm)	11-7/8" (302mm)	6-5/8" (168mm)	32-1/4" (819mm)	9-1/4" (235mm)	112 lbs (51 kg)
8" (200mm)	30-3/4" (880mm)	5-3/4" (146mm)	12-5/8" (321mm)	23-3/8" (594mm)	12-3/4" (324mm)	6-5/8" (168mm)	33-7/8" (860mm)	10-1/4" (260mm)	165 lbs (75 kg)

Notes:

1. Dimensions will vary based on make-up tolerances.
2. Shown with grooved inlet test and drain valve for 2-1/2" through 8" models. On 1-1/4", 1-1/2", and 2" models, test and drain valve has threaded inlet.

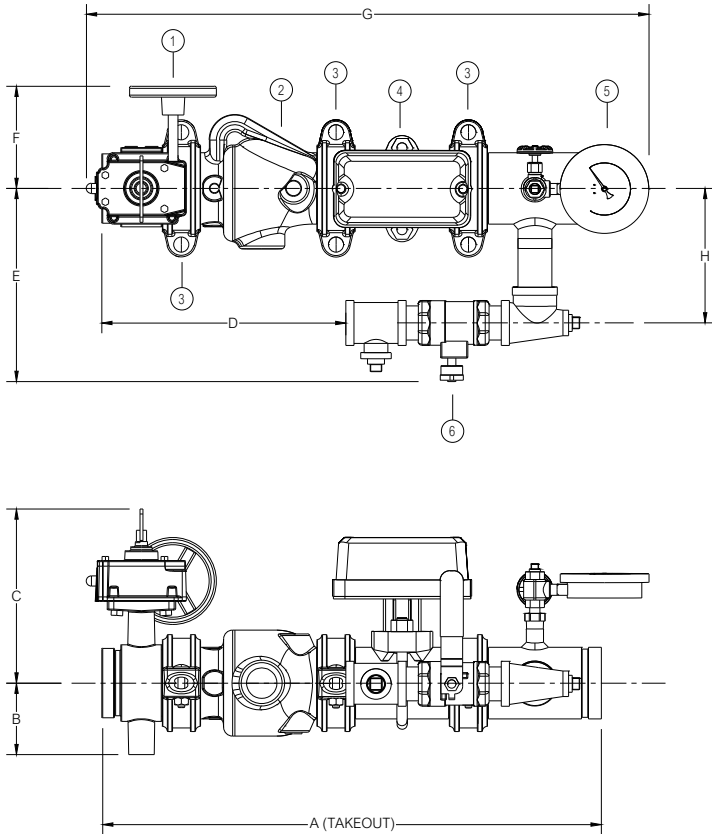

Legend	
Item	Description
1	Control Valve
2	Check Valve
3	Grooved Coupling
4	Water Flow Indicator
5	Pressure Gauge
6	Ball Valve

Size	A	B	C	D	E	F	G	H	Weight (approx.)
1-1/4" (30mm)	23-1/4" (587mm)	1-3/4" (44mm)	6-1/2" (165mm)	12-1/2" (318mm)	6-7/8" (174mm)	2-1/4" (57mm)	25-3/8" (645mm)	4-1/2" (114mm)	19 lbs (8.6 kg)
1-1/2" (50mm)	23-1/4" (590mm)	1-3/4" (44mm)	6-1/2" (165mm)	12-5/8" (321mm)	6-7/8" (174mm)	2-3/8" (60mm)	25-5/8" (651mm)	4-5/8" (117mm)	23 lbs (10.4 kg)
2" (50mm)	23-5/8" (616mm)	2" (51mm)	7-1/2" (191mm)	12-3/4" (324mm)	7" (178mm)	5" (127mm)	27-1/8" (689mm)	4-3/4" (121mm)	30 lbs (13.6 kg)
2-1/2" (65mm)	24" (610)	2-5/8" (67mm)	8-1/4" (210mm)	11-1/4" (286mm)	9-1/8" (231mm)	5" (127mm)	27-1/4" (692mm)	6-1/4" (159mm)	42 lbs (19.1 kg)
3" (76mm)	24-1/2" (620mm)	2-7/8" (73mm)	8-5/8" (219mm)	12" (305mm)	9-1/2" (241mm)	5" (127mm)	27-1/2" (699mm)	6-5/8" (168mm)	49 lbs (22.3 kg)
4" (100mm)	26" (660mm)	3-3/4" (95mm)	9-3/4" (248mm)	11-1/4" (286mm)	11-3/8" (289mm)	5" (127mm)	28-3/4" (730mm)	7-3/8" (187mm)	65 lbs (29.5 kg)
6" (150mm)	29" (735mm)	4-3/4" (121mm)	11" (279mm)	14-3/8" (365mm)	12-3/8" (314mm)	6-5/8" (168mm)	31-3/8" (797mm)	8-3/8" (213mm)	112 lbs (51 kg)
8" (200mm)	30-3/4" (880mm)	5-3/4" (146mm)	12-5/8" (321mm)	16-1/8" (410mm)	13-3/8" (340mm)	6-5/8" (168mm)	33-1/8" (841mm)	9-3/8" (238mm)	165 lbs (75 kg)

Notes:

- Dimensions will vary based on make-up tolerances.
- Shown with grooved inlet test and drain valve for 2-1/2" through 8" models. On 1-1/4", 1-1/2", and 2" models, test and drain valve has threaded inlet.

Installation

The Reliable Model FCA2 Floor Control Assembly shall be installed in accordance with the requirements of applicable NFPA standards and any authorities having jurisdiction. Failure to follow installation instructions and/or revisions to the arrangement of the devices may void the warranty and/or listing of the product.

Prior to installation, verify compatibility of the Model FCA2 materials with the water supply and the environment where the valve will be installed. The Model FCA2 must be installed in a location where the temperature is maintained at a minimum of 50°F (4°C). Heat tracing of wet system valve assemblies is prohibited by NFPA 13.

Connect the inlet of the device to the water supply and the outlet of the device to the fire protection system. Ensure proper direction of flow using the diagrams contained in this bulletin and on the device. Drain should be piped to a location that will avoid damage to property and injury to personnel.

Maintenance

The owner is responsible for maintaining the fire protection system in proper operating condition. Any system maintenance or testing that involves placing a system out of service may eliminate the fire protection that is provided by the fire protection system. Notify any required authorities having jurisdiction and implement appropriate precautions prior to proceeding.

The Reliable Model FCA2 Floor Control Assembly shall periodically be given a thorough inspection and test. NFPA 25, "Inspection, Testing and Maintenance of Water Based Fire Protection Systems," provides minimum maintenance requirements. Replace any components found to be corroded, damaged, worn or non-operable. Increase the frequency of inspections when the valve is exposed to corrosive conditions or chemicals that could impact materials and/or operation of the assembly.

Guarantee

For Reliable Automatic Sprinkler, Co., Inc. guarantee, terms, and conditions, visit www.reliablesprinkler.com.

Ordering Information

Specify:

1. Reliable Model FCA2 Floor Control Assembly
2. Size
3. Test and Drain Orifice Size
4. Optional Adjustable Pressure Relief Valve Kit

Notes:

1. All Model FCA2 Commercial Riser Assemblies come with a 300 psi (20.7 bar) UL Listed pressure gauge for 175 psi (12.1 bar) applications. If the Model FCA2 Commercial Riser Assembly is to be installed in a higher pressure application, please purchase a 600 psi (41.4 bar) (P/N 98248005) pressure gauge. This gauge may or may not be UL Listed at the time of purchase.
2. Unless specified at the time of ordering, pressure relief kits are installed at the factory.
3. The water flow switch for the 1-1/4" (30mm) and 1-1/2" (40mm) Model FCA2 is a proprietary component only available for replacement from Reliable. When ordering, please specify part number 96556923.

For International Use:

When using with 76mm and 165mm pipe, the following RASCO grooved transition couplings may be ordered:

76mm pipe with 2-1/2" (65mm) FCA2: PN 7U99004002
165mm pipe with 6" (150mm) FCA2: PN 7U99004003

6A WW 0 F X YY Z

Size <u>WW</u>	Water Flow Dectector <u>X</u>	Drain Valve Options <u>YY</u>	Pressure Relief Valve <u>Z</u>
01 = 1-1/4" (30mm) 03 = 1-1/2" (40mm) 10 = 2" (50mm)	P = Potter Electric VSR or VSR-S (Standard) X = Potter Electric VSR-FEX Explosion Proof (2" [50mm] - 8" [200mm] only) A = Potter Electric VSR-AT Auto-Test (2" [50mm] - 8" [200mm] only)	00 = 1" (25mm) BALL VALVE 03 = 1" (25mm) RASCO T&D VALVE K2.8 04 = 1" (25mm) RASCO T&D VALVE K4.2 05 = 1" (25mm) RASCO T&D VALVE K5.6	0 = None A = Adjustable ⁽¹⁾⁽²⁾
12 = 2-1/2" (65mm) 14 = 3" (80mm)		01 = 1-1/4" (30mm) BALL VALVE 06 = 1-1/4" (30mm) RASCO T&D Valve K4.2 07 = 1-1/4" (30mm) RASCO T&D Valve K5.6 08 = 1-1/4" (30mm) RASCO T&D Valve K8.0 09 = 1-1/4" (30mm) RASCO T&D Valve K11.2	
16 = 4" (100mm) 18 = 6" (150mm) 19 = 8" (200mm)		02 = 2" (50mm) BALL VALVE 08 = 2" (50mm) RASCO T&D Valve K5.6 09 = 2" (50mm) RASCO T&D Valve K8.0 10 = 2" (50mm) RASCO T&D Valve K11.2 11 = 2" (50mm) RASCO T&D Valve K16.8 12 = 2" (50mm) RASCO T&D Valve K4.2	

Notes:

1. Relief valve is adjustable from 175 to 310 psi (12.1 to 21.4 bar). The pressure markings on the adjustment cap are for reference only. Use a system gauge to verify proper relief setting.
2. Relief valve is UL Listed only and not FM Approved.