

# Reliable®

## Model REL-DV1 1" Full Port Drain Valve with MNPT x FNPT Outlets and Pre-installed Plug

600 psi (41.4 bar)

### Product Description

Reliable Model REL-DV1 full port drain valves include a MNPT outlet and an FNPT outlet that comes plugged with a MNPT plug. This valve is suitable for use as a drain valve for fire protection systems that can be installed in any 1" FNPT threaded outlet, mechanical tee, or other appropriate connection point. The REL-DV1 valve outlets and bore are all 1" NPS. This valve features a forged brass alloy body and bonnet. The REL-DV1 ball valve is designed with a blowout-proof stem for an enhanced level of robustness and is rated for 600 psi (41.4 bar) working pressure. The handle is marked with "Aux Drain" to indicate its function as an auxiliary drain.

### Installation

The Reliable Model REL-DV1 Full Port Drain Valve shall be installed in accordance with NFPA 13, "Standard for the Installation of Sprinkler Systems," as well as the requirements of any authorities having jurisdiction. Verify compatibility of the Full Port Ball Valve materials with the water supply and the environment where the valve will be installed prior to installation.

### Maintenance

The owner is responsible for maintaining the fire protection system in proper operating condition. Any system maintenance or testing that involves placing a control valve out of service will eliminate the fire protection that is provided by the fire protection system.

The Reliable Model REL-DV1 Full Port Drain Valve shall periodically be given a thorough inspection and test. NFPA 25, "Inspection, Testing and Maintenance of Water Based Fire Protection Systems," provides minimum maintenance requirements. Inspect the valve for corrosion, damage, and wear as required and replace as necessary. Increase the frequency of inspections when the valve is exposed to corrosive conditions or chemicals that could impact the valve materials.



Model REL-DV1 Full Port Drain Ball Valve

### Guarantee

For The Reliable Automatic Sprinkler Co. Inc. guarantee, terms, and conditions, visit [www.reliablesprinkler.com](http://www.reliablesprinkler.com).

### Ordering Information

Specify the following when ordering:

**Reliable Model REL-DV1 Full Port Drain Valve**

## Model REL-DV1 Full Port Drain Valves

### Technical Specifications

**Pressure Rating:** 600 psi (41.4 bar)  
**Temperature Rating:** -20°F to 300°F (-29°C to 149°C)

### End Connections

Female NPT per ASME B1.20.1  
 Male NPT per ASME B1.20.1

### Material Specifications

**Body:** C37700 Forged Brass Alloy  
**MNPT Bonnet:** C37700 Forged Brass Alloy  
**Seat:** Virgin PTFE  
**Ball:** C37700 Forged Brass Alloy with chrome electroplating  
**Stem:** C37700 Forged Brass Alloy  
**Stem Packing:** Virgin PTFE  
**Stem Packing Nut:** C37700 Forged Brass Alloy  
**Stem Secondary Seal (o-ring):** Buna-N Nitrile Elastomer  
**FNPT Outlet Plug:** C37700 Forged Brass Alloy  
**Stem Lock Nut:** EN S235 Carbon steel with zinc electroplating  
**Vale Handle:** EN S235 Carbon steel with zinc electroplating



## Model REL-DV1 Full Port Drain Valve Dimensions

Figure 1

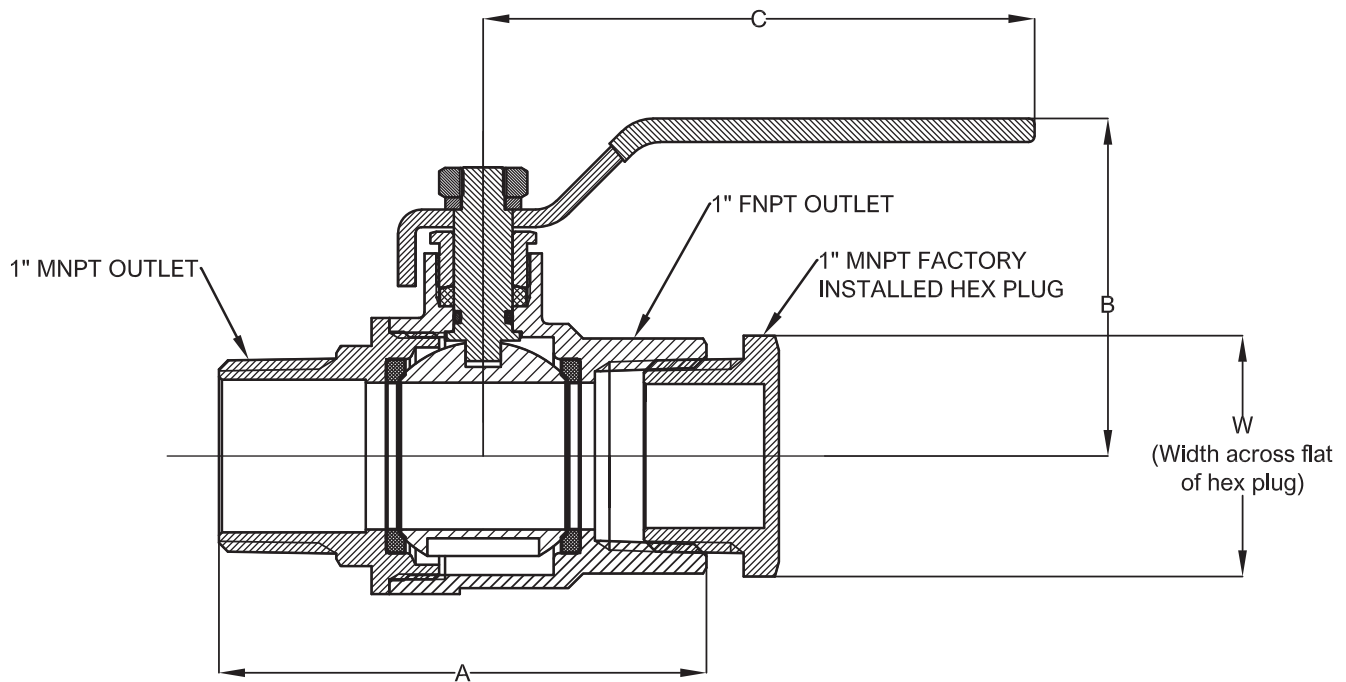

### Dimensions in. (mm)

Table B

Valve Size	A	B	C	W
1" (25)	3-1/4 (83)	2-1/4 (57.2)	4-5/16 (109)	1-7/16 (35.5)

P/N 9999970702