

Reliable®

Model FX Dry Pipe Valve

2" (50mm), 2-1/2" (65mm), 76mm, 3" (80mm),
4" (100mm), 6" (150mm), 165mm

cULus Listed, FM Approved, LPCB Approved

Features

- Lightweight ductile iron body with compact trim
- External reset reduces setup and commissioning time
- Does not require priming water

Product Description

The Reliable Model FX Dry Pipe Valve is a differential-principle, externally resettable valve designed for use as a primary control valve in a dry pipe system. The valve clapper is held in the set position by pneumatic pressure acting on a larger surface area than that of the incoming water pressure. Release of pneumatic pressure from the system allows the dry pipe valve to open. The Model FX valve is available with grooved end, flanged end, or flange x grooved end connections (see Table A).

When required, all sizes of the Model FX valve may be equipped with the Reliable Model B1 Accelerator (PN 650120001A; ordered separately). The accelerator is a normally closed valve that opens upon a predetermined rate of air or nitrogen pressure loss. When the accelerator opens, air or nitrogen pressure is directed to the intermediate chamber of the Model FX valve, hastening the valve trip time. Please refer to Reliable Technical Bulletin 323 for further information.



Note: Pressure switches (low air and flow alarm) provided with fully assembled valves only. Order separately with loose and segmented trim.

Model FX Dry Pipe Valve Technical Data

Model FX Dry Pipe Valve Technical Data					Table A
Valve Size	End Connection	Fully Assembled Weight (w/o Control Valve) lbs (kg)	Approximate Shipping Weight for Valve Fully Assembled with Trim lbs (kg)	Rated Pressure psi (bar)	Listings and Approvals
2" (50mm)	Groove/Groove	42 (19)	82 (37)	250 (17.2)	cULus FM LPCB
2-1/2" (65mm)	Groove/Groove	55 (25)	115 (52)	300 (20.7)	
76mm	Groove/Groove	55 (25)	120 (54)		
3" (80mm)	Groove/Groove	56 (25)	120 (54)		
4" (100mm)	Groove/Groove	78 (35)	155 (70)		
	Flange/Groove	90 (41)	167 (76)		
	Flange/Flange	102 (46)	179 (81)		
6" (150mm)	Groove/Groove	127 (58)	234 (106)		
	Flange/Groove	136 (62)	252 (114)		
	Flange/Flange	163 (74)	270 (122)		
165mm	Groove/Groove	127 (58)	234 (106)		

Notes:

1. Grooved ends per ANSI/AWWA C606; flanged ends per ASME B16.5 Class 150, BS10 BS-E, or ISO 7005-2 PN16 (specify).
2. Valves are intended to be installed on systems where the pressure does not exceed the working capabilities of the end configurations.
3. Approximate shipping weight given for fully assembled valve and trim, including control valve and accelerator.

Model FX Dry Pipe Valve

Technical Specifications

Pressure Rating: See Table A

Material Specifications

Body & Cover: Ductile Iron, painted

Clapper: Stainless Steel

Seat: EPDM Rubber/Aluminum

Trim: Galvanized Steel

End Connections

See Table A

Installation Orientation

Vertical (Up Through Valve)

Approvals

cULus Listed

FM Approved

LPCB Approved

(EN 12259-3:2000)



Model FX Dry Pipe Valve Components and Dimensions

Figure 1

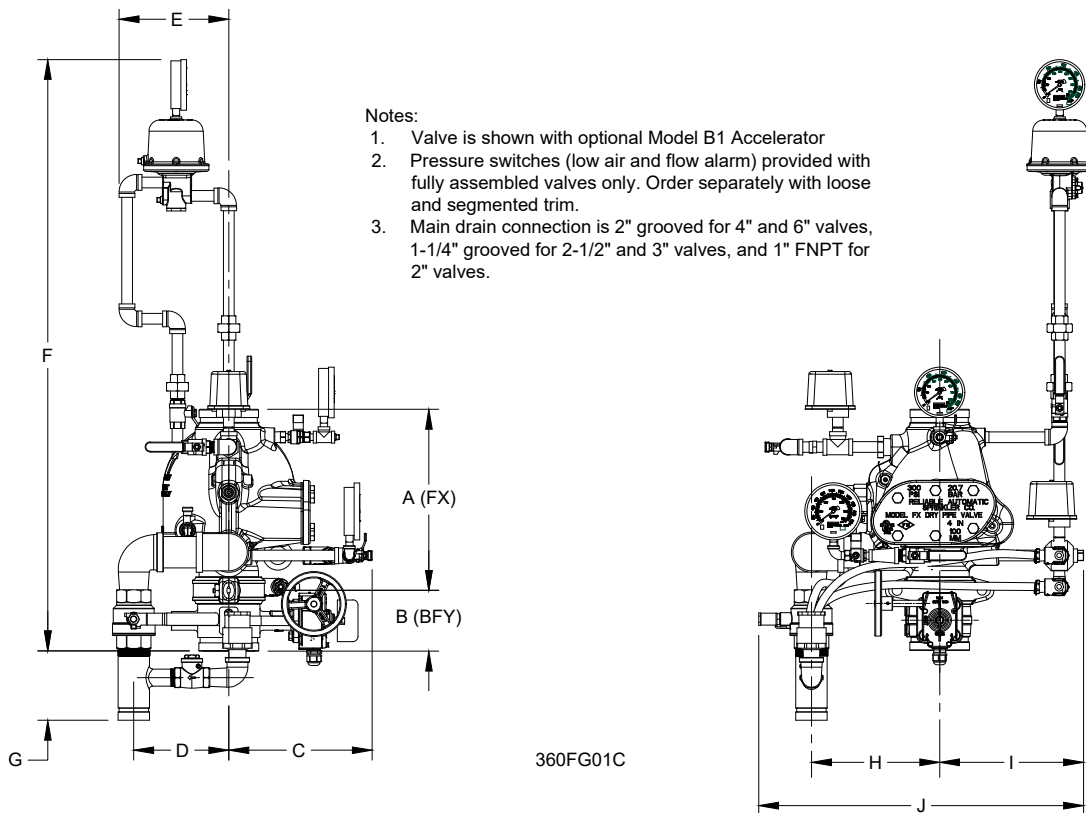

Model FX Dry Pipe Valve Dimensions - in. (mm)

Table B

Valve Size	A	B	C	D	E	F	G	H	I	J
2" (50mm)	10 (254)	3-7/8 (98)	10 (254)	7 (178)	8-1/4 (210)	40 (1016)	3/4 (19)	7-1/4 (184)	9-5/8 (244)	21-3/8 (543)
2-1/2" (65mm), 3" (80mm), & 76mm	12-1/4 (311)	3-7/8 (98)	10-1/4 (260)	7-3/8 (187)	8-1/4 (210)	43-3/4 (1111)	5-7/8 (149)	8-1/4 (210)	10-1/8 (257)	22 (559)
4" (100mm)	13-3/4 (349)	4-9/16 (116)	10-7/8 (276)	7-1/2 (191)	8-1/4 (210)	45-5/8 (1159)	4-7/8 (124)	9-5/8 (244)	10-3/4 (273)	24-1/2 (622)
6" (150mm), 165mm	16 (406)	5-7/8 (149)	12-1/2 (318)	7-1/2 (191)	8-1/4 (210)	47-1/2 (1207)	4 (102)	11-1/2 (292)	12 (305)	30-1/2 (775)

Note: Dimension A (body take-out) is same for all end configurations. Dimension B (control valve) is not applicable to 76mm and 165mm valves as well as flanged valves.

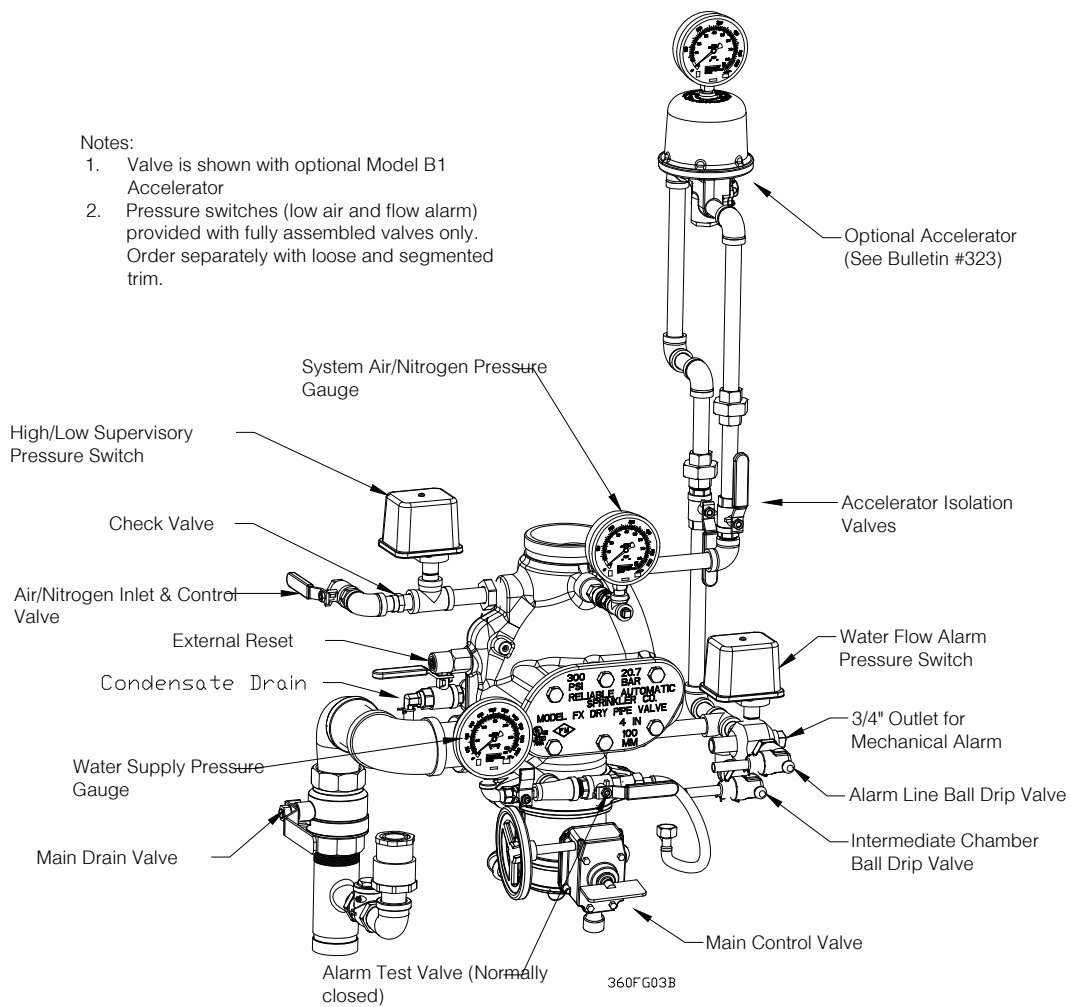
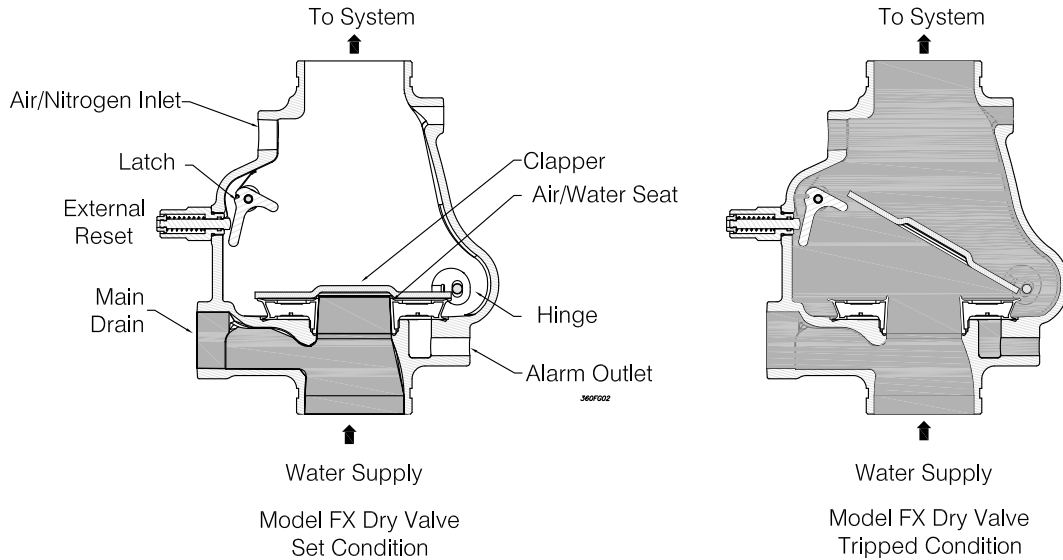

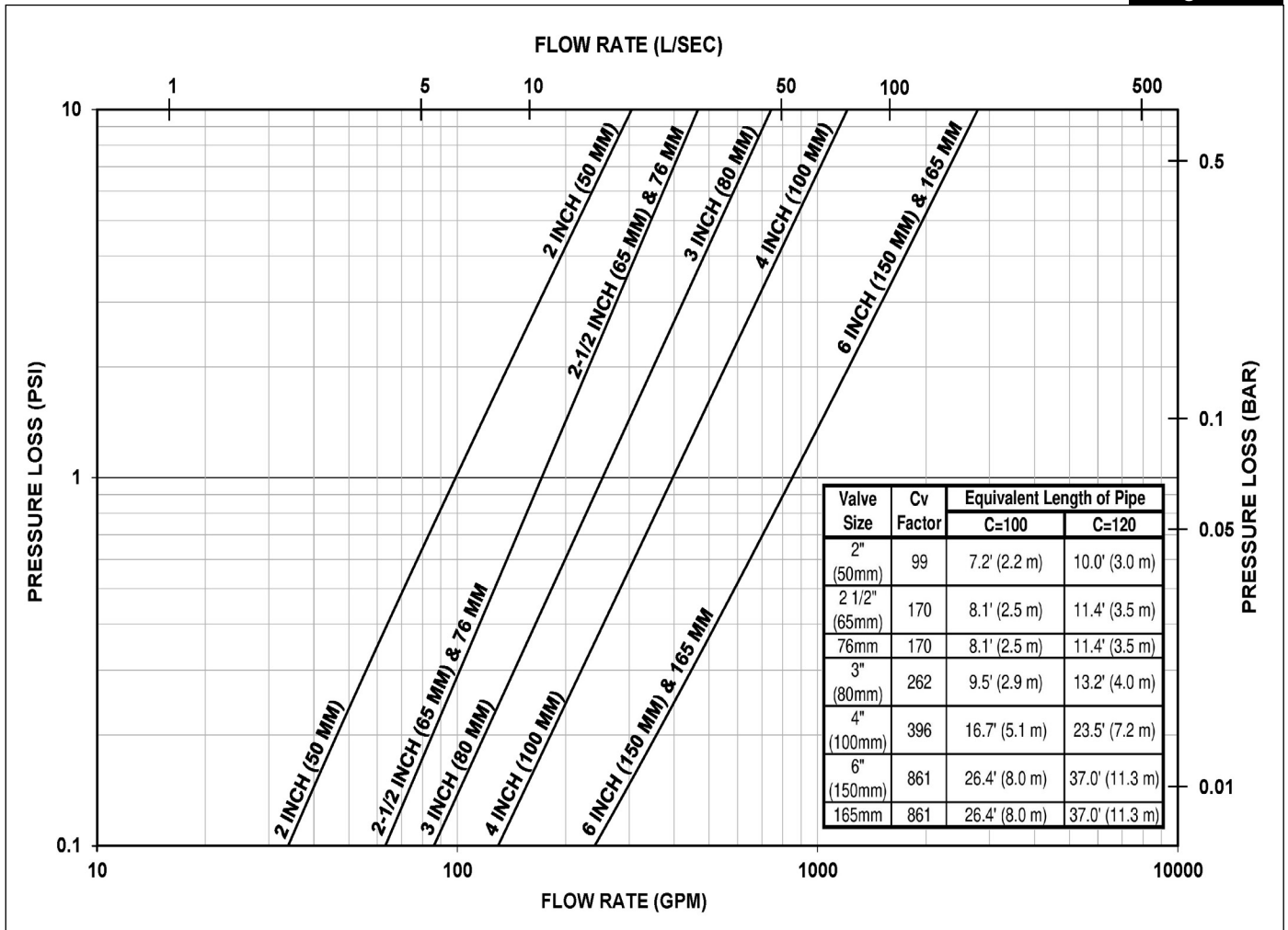

Operation

The Reliable Model FX Dry Pipe Valve is shown in both the closed and open position in Figure 2. The upper surface area of the clapper is approximately six times larger than the surface area of the bottom of the clapper that is exposed to the water supply in the set position. In the closed position, pneumatic pressure acts on the larger upper surface of the clapper while water pressure acts on the smaller lower surface area. Because of this surface area differential, one psi of pneumatic pressure can offset approximately six psi of water pressure. Table C provides the appropriate pneumatic pressure to water pressure ratio.

When a sprinkler operates, the upward force of the water pressure acting beneath the clapper overcomes the reduced pneumatic pressure and allows the clapper to open. Water then flows through the Model FX Dry Pipe Valve into the system piping and into the alarm outlet activating the alarm device(s). Once the clapper has opened, the lever acts as a latch preventing the clapper from returning to the closed position until manually reset.

Pneumatic Pressure Requirement

Table C

Water Pressure psi (bar)	Pneumatic Pressure psi (bar)	
	Maximum	Not More Than
20 (1.37)	10 (0.68)	20 (1.37)
50 (3.45)	15 (1.03)	25 (1.72)
75 (5.17)	20 (1.37)	30 (2.06)
100 (6.89)	25 (1.72)	35 (2.41)
125 (8.62)	30 (2.06)	40 (2.75)
150 (10.34)	35 (2.41)	45 (3.10)
175 (12.07)	40 (2.75)	50 (3.45)
200 (13.79)	45 (3.10)	55 (3.79)
225 (15.51)	50 (3.45)	60 (4.14)
250 (17.24)	55 (3.79)	65 (4.48)
275 (18.96)	60 (4.14)	70 (4.83)
300 (20.68)	65 (4.48)	75 (5.17)

Installation

The Model FX Dry Pipe Valve shall be installed in accordance with NFPA 13, "Standard for the Installation of Sprinkler Systems," as well as the requirements of any authorities having jurisdiction. The direction of flow shall be up through the assembly. Failure to follow installation instructions may void the warranty and/or listing of the valve. Verify compatibility of the Model FX Dry Pipe Valve materials with the water supply and the environment where the valve will be installed prior to installation.

The Model FX Dry Pipe Valve must be installed in a readily visible and accessible location where a minimum temperature of 40°F (4°C) or above must be maintained. Heat tracing of the Model FX Dry Pipe Valve and trim is not permitted. Heat tracing can result in the formation of hardened mineral deposits that can prevent proper operation of the dry pipe valve.

The valve and trim kit have been tested, approved and listed in accordance with UL and FM standards. Hydrostatically testing the valve and trim to pressures higher than their rating is limited to the hydrostatic test as referenced by NFPA 13.

Normal operation and hydrostatic testing do not address the possibility of a water hammer which may damage the valve. A water hammer can create pressure more than the rated pressure of the equipment and should be avoided by all necessary means. Water hammer can occur from (but is not limited to) improper fire pump settings, underground construction work, or improper venting of trapped air in piping.

Please note that residual pressure readings taken when flowing a main drain vary between valve models and manufacturers. Comparison of pressure readings should only be made to the initial pressure reading taken following installation and commissioning of the same valve.

Friction Loss (Equivalent Length of Schedule 40 Pipe)

Size	Table D		
	C = 100 ft (m)	C = 120 ft (m)	Cv Value
2" (50mm)	7.2 (2.2)	10.0 (3.0)	99
2-1/2" (65mm), 76mm	8.1 (2.5)	11.4 (3.5)	170
3" (80mm)	9.5 (2.9)	13.2 (4.0)	262
4" (100mm)	16.7 (5.1)	23.5 (7.2)	396
6" (150mm), 165mm	26.4 (8.0)	37 (11.3)	861

Model FX Dry Pipe Valve Set Up Procedure (Reference Figure 3)

1. Close the Main Control Valve and close the Air/Nitrogen Control Valve.
2. Open the Main Drain Valve and drain the system.
3. Open all drain valves and vents at low points throughout the system, closing them when flow of water has stopped.
4. Inspect and replace any necessary portions of the sprinkler system subjected to fire conditions.
5. Push in the plunger of the Intermediate Chamber Ball Drip Valve and the Alarm Line Ball Drip Valve to force the ball from its seat to drain any water in the lines.
6. When standing in front of the valve, locate the External Reset on the left side of the dry valve body. Push in on the plunger in the center of the External Reset until you hear a distinct clicking noise indicating that the clapper has closed. A tool, such as a screwdriver, may be needed to press the External Reset plunger.
7. Open the Air/Nitrogen Control Valve and rapidly apply compressed air or nitrogen into the Model FX Dry Pipe Valve system until the pressure conforms to the level indicated in Table C, as indicated on the System Pressure Gauge. Set the air or nitrogen supply to automatic operation.
8. Partially open the Main Drain Valve.
9. Slightly open the Main Control Valve until water begins to flow through the Main Drain Valve.
10. Once water begins to flow through the Main Drain Valve, slowly close the Main Drain Valve.
11. If installed, reset the Model B1 Accelerator per Reliable Technical Bulletin 323 and open the Accelerator Isolation Valves.
12. Observe if water leaks through the Intermediate Chamber Ball Drip Valve into the closed drain. If no leak occurs, the dry pipe valve clapper is sealed.
13. Slowly open the Main Control Valve. Verify that the Main Control Valve is fully open and properly monitored.

Alarm Test

1. Notify the owner and monitoring company that testing is being performed on the system.
2. Open the Alarm Test Valve.
3. Verify that pressure alarm switch has activated, and signal has been reported to the fire alarm system.
4. Close the Alarm Test Valve.
5. Push in the plunger of the Alarm Line Ball Drip Valve to force the ball from its seat to relieve pressure and drain any water in the line.
6. When testing is complete, notify the owner and monitoring company that the system has been returned to service.

Maintenance

The owner is responsible for maintaining the fire protection system in proper operating condition. Any system maintenance or testing that involves placing a system out of service may eliminate the fire protection that is provided by the fire protection system. Notify any required authorities having jurisdiction and implement appropriate precautions prior to proceeding.

The Reliable Model FX Dry Pipe Valve shall periodically be given a thorough inspection and test. NFPA 25, "Inspection, Testing and Maintenance of Water Based Fire Protection Systems," provides minimum maintenance requirements. Replace any components found to be corroded, damaged, worn or non-operable. Increase the frequency of inspections when the valve is exposed to corrosive conditions or chemicals that could impact materials and/or operation of the assembly.

Excess water may settle above the valve clapper following hydrostatic testing, system activation, or as a result of condensation. To remove excess water from the system:

1. Notify the owner and monitoring company that maintenance is being performed on the system.
2. Close the Main Control Valve and close the Air/Nitrogen Control Valve.
3. If an Accelerator is present, close the Accelerator Isolation Valves.
4. Open the Main Drain Valve.
5. Open the Condensate Drain Valve on the left rear of the dry pipe valve body until all water has drained. Close Condensate Drain Valve immediately when the flow of water has stopped.
6. Open the Air/Nitrogen Control Valve and allow pneumatic pressure to return to normal (refer to Table C). Set pneumatic supply to automatic operation.
7. If an Accelerator was isolated in step three, open the Accelerator Isolation Valves.
8. Open the Main Control Valve until water begins to flow through the Main Drain Valve.
9. Slowly close the Main Drain Valve.
10. Fully open the Main Control Valve. Verify that the Main Control Valve is fully open and properly monitored.
11. Notify the owner and monitoring company that the system has been returned to service.

Guarantee

For Reliable Automatic Sprinkler, Co., Inc. guarantee, terms, and conditions, visit www.reliablesprinkler.com.

Ordering Information

Specify:

- Model FX Dry Pipe Valve
- Size
- End Connections
- Trim*
 - Fully assembled with control valve
 - Fully assembled without control valve
 - Segmented trim (control valve not included)
 - Loose trim (control valve not included)
- (Optional) Model B1 Accelerator (PN 650120001A)

***Note:** Low pressure switch (PN 6990006381) and alarm pressure switch (PN 6990006382) are included with fully assembled trims only. Order separately when selecting segmented or loose trim.

Service Kits

Service kits are available for routine servicing of the valve (reference assembly drawings on website). Service kits for the Model FX Dry Pipe Valve include the following components:

- Seal Assembly (item 4)
- Cover Gasket (item 5)
- Grease (item 17)

Note: Seat and seal is an integral unit. Replacement requires the appropriate Seat Installation Wrench.

- 2" Model FX Seat Wrench: PN 6881702000
- 2-1/2" and 3" Model FX Seat Wrench: PN 6881703000
- 4" Model FX Seat Wrench: PN 6881704000
- 6" Model FX Seat Wrench: PN 6881706000

65080 X Y Z 00

Valve Size X	End Connection Y	Trim Z
2 = 2" (50mm)*	7 = Groove/Groove	0 = W/O Control Valve, W/O Accelerator
1 = 2-1/2" (65mm)*	8 = Flange/Groove, Class 150	1 = W/ Control Valve, W/O Accelerator*
7 = 76mm*	9 = Flange/Groove, BS-E	3 = W/O Control Valve, W/ Accelerator
3 = 3" (80mm)*	A = Flange/Groove, PN16	4 = W/ Control Valve, W/ Accelerator*
4 = 4" (100mm)	B = Flange/Flange, Class 150	
6 = 6" (150mm)	C = Flange/Flange, BS-E	
5 = 165mm*	E = Flange/Flange, PN 16	

***Note:** Available only with Groove/Groove connections

**Model FX Valve Only (No Trim)
Part Number**

Figure 6

61010 XX 60 Y

Valve Size XX	End Connection Y
20 = 2" (50mm)*	7 = Groove/Groove
25 = 2-1/2" (65mm)*	8 = Flange/Groove, Class 150
76 = 76mm*	9 = Flange/Groove, BS-E
30 = 3" (80mm)*	A = Flange/Groove, PN16
40 = 4" (100mm)	B = Flange/Flange, Class 150
60 = 6" (150mm)	C = Flange/Flange, BS-E
65 = 165mm*	E = Flange/Flange, PN 16

***Note:** Available only with Groove/Groove connections

Weight (Valve Only)

Figure 7

Size	End Connection lbs (kg)		
	GRV/GRV	FLG/GRV	FLG/FLG
2" (50mm)	22 (10)	N/A	N/A
2-1/2" (65mm) & 76 mm	34 (16)	N/A	N/A
3" (80mm)	35 (15)	N/A	N/A
4" (100mm)	52 (24)	64 (29)	76 (35)
6" (150mm)	101 (46)	119 (54)	137 (62)
165mm	101 (46)	N/A	N/A

Weight (Trim Only)

Figure 9

Size	Loose Trim lbs (kg)	Segmentally Assembled Trim lbs (kg)
2" (50mm)	20 (9)	23 (10)
2-1/2" (65mm), 76mm, & 3" (80mm)	21 (10)	25 (11)
4" (100mm), 6" (150mm), & 165mm	26 (12)	30 (14)

Model FX Trim Only Part Number

Figure 8

Valve Size	Trim Part Numbers	
	Loose	Segmentally Assembled
2" (50mm)	6508000001	65080000011
2-1/2" (65mm), 76mm, & 3" (80mm)	6508000002	65080000012
4" (100mm), 6" (150mm), 165mm	6508000003	65080000013