

# Reliable®

## Model N252EC Pendent and Recessed Pendent Sprinkler

Storage and Non-Storage Sprinkler  
K25.2 (360 metric), SIN RA0842

### Features

- 196 ft<sup>2</sup> (18.2 m<sup>2</sup>) max. coverage area
- cULus Listed for unobstructed or noncombustible obstructed construction
- CMSA criteria and RTI to meet the requirements of the International Fire Code for elimination of smoke/heat vents

### Product Description

Reliable Model N252EC Pendent and Recessed Pendent Sprinklers are standard response, control mode density/area extended coverage sprinklers for storage and non-storage applications in accordance with the design requirements of NFPA 13.

The Model N252EC sprinkler may also be used as a control mode specific application sprinkler in accordance with the Alternative Sprinkler Systems Design chapter for NFPA 13 (Chapter 21 in the 2013 & 2016 ed.; Chapter 24 in the 2019 and 2022 ed.). Specific Application design criteria is described in Table C.

The Model N252EC is FM Approved as a quick-response extended coverage sprinkler for storage and non-storage applications in accordance with FM Global Data Sheets.

The Model N252EC sprinkler complies with the requirements in NFPA 13 (2019 ed.) Section 21.9 for the protection of storage and display in retail stores.

The Model N252EC sprinkler is also used as part of the N-RACK-EC® extended coverage in-rack sprinkler system. Details of the system may be found in NFPA13 (2019 ed.) Section 25.8.3 and FM Data Sheet 8-9.

The Model N252EC sprinkler offers a maximum coverage area of 196 ft<sup>2</sup> (18.2 m<sup>2</sup>), which is almost twice that provided by standard coverage sprinklers. This offers the advantage of decreasing the total number of sprinklers, reducing labor and material costs.



Model N252EC Pendent (with optional K25 guard, right)



Recessed Pendent (UL only)

### Model N252EC Specifications

						Table A	
Style	Listings and Approvals	Sensitivity	Response Time Index RTI [m.s] <sup>1/2</sup>	Max Coverage Area	Temperature Rating °F (°C)	Pressure Rating psi (bar)	
Pendent	cULus, FM	Standard (cULus) Quick (FM)	Less than 50	196 ft <sup>2</sup> (18.2 m <sup>2</sup> )	165°F (74°C) 212°F (100°C)	175 (12)	
Recessed Pendent	cULus	Standard					

**Model N252EC Sprinkler**

**SIN RA0842**

**Technical Specifications**

**Style:** Pendent or Recessed Pendent  
**Threads:** 1" NPT or ISO 7-1R1  
**Nominal K-Factor:** 25.2 (360 metric)  
**Max. Working Pressure:** 175 psi (12 bar)

**Material Specifications**

**Thermal Sensor:** Beryllium Nickel Solder Link  
**Sprinkler Frame:** Brass Alloy  
**Button:** Copper Alloy  
**Sealing Assembly:** Nickel Alloy with PTFE  
**Load Screw:** Bronze  
**Deflector:** Bronze Alloy  
**Levers:** Stainless Steel Alloy

**Sprinkler Finishes**

(See Table D)

**Sensitivity**

Standard Response (cULus)  
 Quick Response (FM)

**Temperature Ratings**

165°F (74°C) (black link)  
 212°F (100°C) (white link)

**Recessed Escutcheons**

Model FP recessed escutcheon (cULus only)

**Guards**

Model 25 (FM Approved for use as an in-rack sprinkler only)

**Sprinkler Wrenches**

Model W5 (pendent)  
 Model N (recessed)

**Listings and Approvals**

cULus Listed  
 FM Approved



**Model N252EC Pendent Sprinkler Components and Dimensions**

**Figure 1**

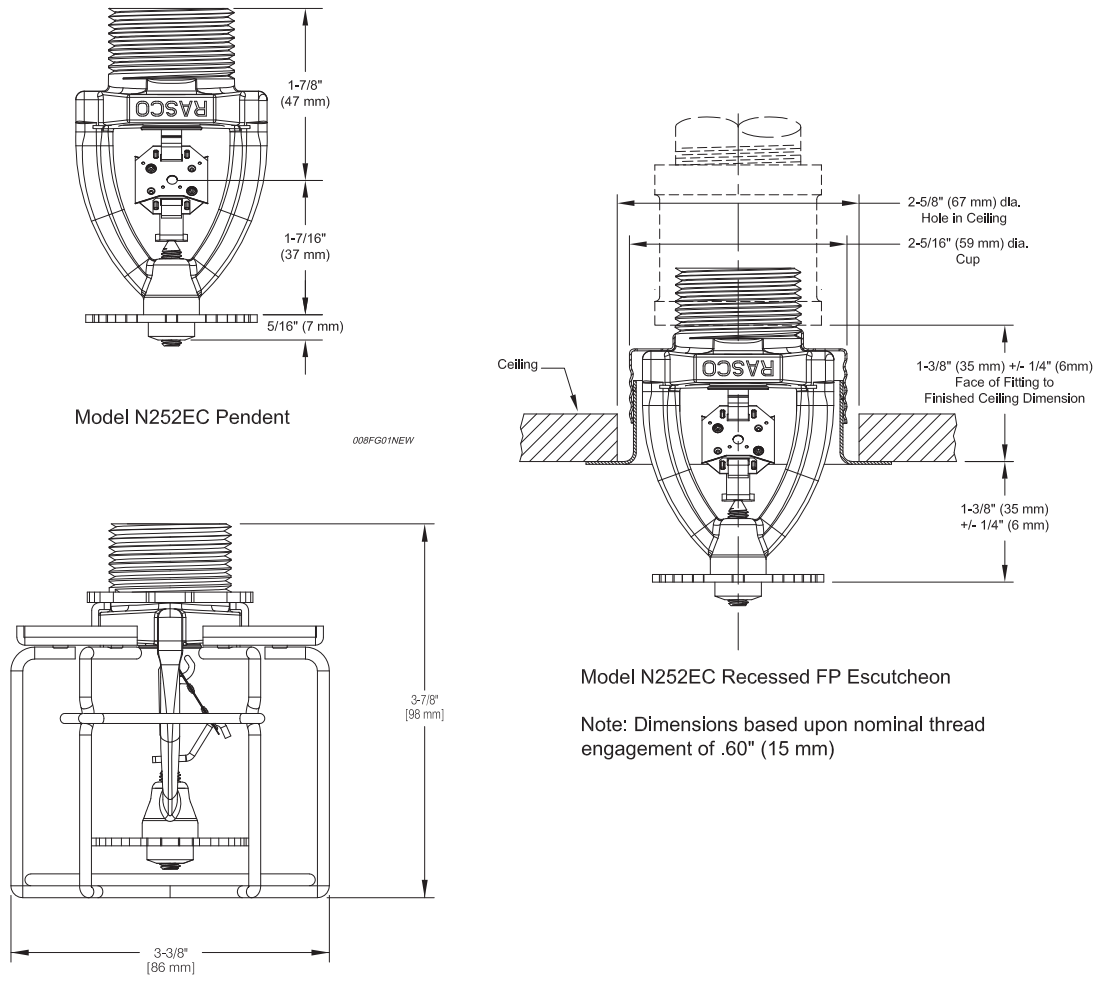

Model N252EC Pendent with Model 25 Guard  
 (Shown rotated 90 degrees; FM Approved for use as an in-rack sprinkler)

**Model N252EC Commodity Selection and Design Criteria Overview**

**Table B**

<b>Storage Type</b>	<b>NFPA</b>	<b>FM GLOBAL</b>
Sprinkler Type	CMDA	Storage and Non-storage
Response Type	Standard Response	Quick Response
System Type	Wet	Wet
Temperature Rating	165°F, 212°F (74°C, 100°C) <sup>(1)</sup>	165°F, 212°F (74°C, 100°C)
Roof Construction	Unobstructed and Noncombustible Obstructed	See FM Global 2-0
Ceiling Slope	See NFPA 13	See FM Global 2-0
Maximum Coverage Area	196 ft <sup>2</sup> (18.2m <sup>2</sup> )	See FM Global 2-0
Minimum Coverage Area	See NFPA13	See FM Global 2-0
Maximum Spacing	14' (4.3m) where coverage area exceeds 144 ft <sup>2</sup> (13.5 m <sup>2</sup> ) 15' (4.6m) where coverage area is 144 ft <sup>2</sup> (13.5m <sup>2</sup> ) or less	See FM Global 2-0
Minimum Spacing	8' (2.4m)	See FM Global 2-0
Minimum Clearance to Commodity	3' (900mm) <sup>(2)</sup>	See FM Global 2-0
Sprinkler Distance to Ceiling	See NFPA 13	See FM Global 2-0
Open Frame, Single, Double, Multiple Row, or Portable Rack Storage of Class I - IV, Cartoned Unexp Plastics	See NFPA 13	See FM 2-0 & 8-9
Solid Pile or Palletized Storage of Class I - IV and Cartoned Unexp Plastics	See NFPA 13	See FM 2-0 & 8-9
Idle Pallet Storage	N/A	N/A
Rubber Tire Storage	N/A	See FM 2-0 & 8-3
Rolled Paper Storage	N/A	N/A
Flammable Liquid Storage	N/A	See FM 7-29
Aerosol Storage	N/A	N/A
Auto Components in Portable Racks	See NFPA 13	See FM 2-0 and 8-9

**Notes:**

<sup>(1)</sup> The cULus Listing for the sprinkler permits design criteria for high temperature CMDA sprinklers to be used with ordinary and intermediate temperature N252EC sprinklers.

<sup>(2)</sup> A minimum operating pressure of 22 psi (1.5 bar) is required for clearances less than 4' (1.2 m).

Storage Type	Specific Application Criteria
Sprinkler Type	Storage, CMSA
Temperature Rating	165°F, 212°F (74°C, 100°C)
Response Type	Quick Reponse
System Type	Wet
Maximum Area of Coverage	196 ft <sup>2</sup> (18.2m <sup>2</sup> )
Minimum Area of Coverage	100 sq. ft. (9.3m <sup>2</sup> )
Maximum Slope Ceiling	2/12 pitch
Maximum Spacing	14' (4.3m)
Minimum Spacing	NFPA 13: 8' (2.4m) FM: 10' (3.0m)
Deflector to Top of Storage	Minimum 3' (900mm)
Deflector Distance	In accordance with NFPA 13 for Extended Coverage Upright and Pendent Sprinklers
Maximum Ceiling Height	35' (10.7m)
Maximum Storage Height	30' (9.1m)
Storage Arrangement	Storage arrangements as outlined in Chapter 21 (2013, 2016 ed.) or Chapter 24 (2019, 2022 ed.) of NFPA 13 for Extended Coverage Sprinklers
Commodity	Class I-IV commodities and Cartoned Unexpanded plastics
Sprinkler System Design	In accordance with Chapter 21 (2013, 2016 ed.) or Chapter 24 (2019, 2022 ed.) of NFPA 13 for Extended Coverage Sprinklers
Obstruction Criteria	In accordance with Chapter 21 (2013, 2016 ed.) or Chapter 24 (2019, 2022 ed.) of NFPA 13 for Extended Coverage Sprinklers
Minimum Aisle Width	N/A
Hose Stream Allowance and Duration	250 GPM (950 lpm) for 60 minutes

**\*Note:** CMSA criteria is based on the original FM Approval for the Model N252EC sprinkler, which is now included in Chapter 21 (2013, 2016 ed.) and Chapter 24 (2019 ed.) of NFPA 13. Additional design criteria for the Model N252EC sprinkler may be found in FM Global Property Loss Prevention Data Sheet 8-9. The Model N252EC sprinkler is described as a quick-response K25.2EC pendent storage sprinkler in FM Global Data Sheet 8-9.

## Sprinkler and Escutcheon Finishes<sup>(1)</sup>

Table D

Standard Finishes		Special Application Finishes	
Sprinkler	FP Escutcheons <sup>(2)</sup>	Sprinkler	FP Escutcheons <sup>(2)</sup>
Brass	Brass	Bright Brass	Bright Brass
Chrome Plated	Chrome Plated	Satin Chrome	Satin Chrome
White Polyester	White Polyester	Black Polyester	Black Polyester
		Custom Color Polyester	Custom Color Polyester

### Notes:

1. Paint or any other coating applied over the factory finish will void all approvals and warranties.
2. Model FP escutcheon assembly consists of an unfinished galvanized cup and a finished trim ring.

## Installation

Model N252EC series sprinklers must be installed in accordance with the requirements of the NFPA 13 for pendent sprinklers and may also be installed as a recessed sprinkler. The Model FP recessed escutcheon is the only recessed escutcheon to be used with Model N252EC sprinklers. Use of any other recessed escutcheon will void all approvals and warranties. Do not install Model FP escutcheons in ceilings that are positively pressurized with respect to the occupied space below.

When installing Model N252EC sprinklers use only the Model W5 wrench for pendent installations and the Model N wrench for recessed pendent installations. Use of wrenches other than those specified may damage these sprinklers.

Sprinklers should be tightened between 22 to 30 ft.- lbs. (30 - 41 Nm) torque. Do not tighten sprinklers over the maximum recommended torque. Sprinklers not tightened to recommended torque may cause leakage or impairment of the sprinklers.

## Maintenance

### Wrenches

Figure 2

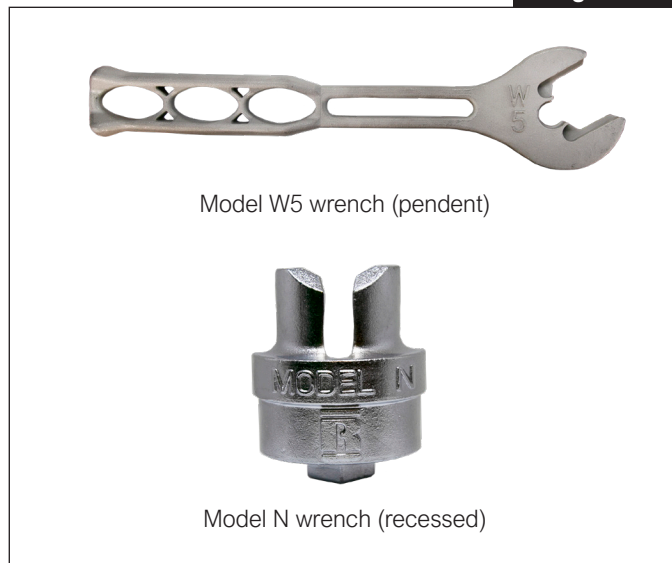

Reliable Model N252EC series sprinklers should be inspected and the sprinkler system maintained in accordance with NFPA 25, as well as the requirements of any Authorities Having Jurisdiction.

Prior to installation, sprinklers should remain in the original cartons and packaging until used. This will minimize the potential for damage to sprinklers that could cause improper operation or non-operation.

Do not clean sprinklers with soap and water, ammonia liquid or any other cleaning fluids. Remove dust by gentle vacuuming without touching the sprinkler.

Replace any sprinkler which has been painted (other than factory applied). Model FP escutcheons have holes in the cup that must remain unobstructed. Replace any sprinkler which has been damaged. A stock of spare sprinklers should be maintained to allow quick replacement of damaged or operated sprinklers.

Failure to properly maintain sprinklers may result in inadvertent operation or non-operation during a fire event.

## Guarantee

For the Reliable Automatic Sprinkler Co., Inc. guarantee, terms, and conditions, visit [www.reliablesprinkler.com](http://www.reliablesprinkler.com).

## Ordering Information

Specify the following when ordering.

### Sprinkler

- Model N252EC - pendent or recessed pendent
- Temperature Rating
- Threads (1" NPT or ISO 7-1 R1)
- Finish (See Table D)

### Guard

- Model 25

### Escutcheon

- Type (FP)
- Finish (See Table D)

### Sprinkler Wrench

- Model W5 (Pendent)
- Model N (Recessed)