

Reliable®

Model DDX Deluge Valve Wet-Pilot, Dry-Pilot, and Electric Release Trims

Features

- Straight through design, low friction loss
- Mechanical valve with latching clapper
- Intermediate chamber built into seat
- Externally resettable

Product Description

The Model DDX deluge valve is a hydraulic piston operated, mechanical type deluge valve. The valve is designed for use as a primary control valve in deluge, preaction or special types of fire protection systems. Following operation, the valve is able to be reset externally.

When the side chamber of the Reliable Model DDX Deluge Valve is pressurized, hydraulic supply pressure acts on the piston and pushrod assembly and simultaneously on the underside of the clapper. The resultant force of the supply pressure acting on the piston/pushrod is multiplied by the mechanical advantage of the lever and is more than sufficient to hold the clapper closed against normal supply pressure surges.

When a releasing device vents the pushrod chamber to atmosphere through the chamber's outlet, the pushrod chamber pressure falls instantaneously. When the hydraulic pressure in the pushrod chamber approaches approximately one-third of the supply pressure, the upward force of the supply pressure acting beneath the clapper overcomes the lever-applied force thereby opening the clapper. Once the clapper has opened, the lever acts as a latch, preventing the clapper from returning to the closed position. Water from the supply flows through the Model DDX Deluge Valve into the system piping. Water also flows through the valve's alarm outlet to any attached alarm devices.



Reliable Model DDX Deluge Valve
(Electric Release Shown)

After system shutdown, the Model DDX Deluge Valve may be reset externally using the reset knob at the rear of the valve. The external reset feature of the Model DDX Deluge Valve provides a means for placing the fire protection system into service without having to remove the face plate of the valve.

Model DDX Valve Listings and Approvals

Table A

Valve Size	End Connection ⁽¹⁾	Pressure Rating ⁽²⁾⁽³⁾	Listings & Approvals
2" (50mm), 2-1/2" (65mm), 76mm, & 3" (80mm)	Groove/Groove	250 psi (17,2 bar)	cULus, FM, CE, VdS
4" (100mm)	Groove/Groove	300 psi (20,7 bar)	cULus, FM, CE, VdS, LPCB
	Flange/Groove		
	Flange/Flange		
6" (150mm)	Groove/Groove	300 psi (20,7 bar)	cULus, FM, CE, VdS
	Flange/Groove		
	Flange/Flange		
165mm	Groove/Groove	300 psi (20,7 bar)	cULus, FM, CE, VdS
8" (200mm)	Groove/Groove	250 psi (17,2 bar)	cULus, FM, CE, VdS, LPCB
	Flange/Flange		

Notes:

1. Grooved ends per ANSI/AWWA C606; flanged ends per ASME B16.5 Class 150 or ISO 7005-2 PN16 (specify).
2. For electric release, when fitted with 300 psi (20.7 bar) solenoid valve.
3. Valves are intended to be installed on systems where the pressure does not exceed the working capabilities of the end configurations.

Valve Details
Table B

Valve Size:	End Connection:	End to End:	Weight:	Color
2" (50mm), 2½" (65mm), 76mm & 3" (80mm)	Groove/ Groove	12½" (318mm)	34 lbs (15 kg)	Black or Red
4" (100mm)	Groove/ Groove	14" (356mm)	64 lbs (29 kg)	Black or Red
	Flange/ Groove	16" (406mm)	79 lbs (36 kg)	Red
	Flange/ Flange	16" (406mm)	92 lbs (42 kg)	Black or Red
6" (150mm)	Groove/ Groove	16" (406mm)	95 lbs (43 kg)	Black or Red
	Flange/ Groove	19" (483mm)	122 lbs (56 kg)	Red
	Flange/ Flange	19" (483mm)	138 lbs (69 kg)	Black or Red
165mm	Groove/Groove	16" (406mm)	95lbs (43kg)	Red
8" (200mm)	Groove/ Groove	19 ³ / ₈ " (492mm)	148 lbs (67 kg)	Black or Red
	Flange/ Flange	21¼" (540mm)	197 lbs (90 kg)	Black or Red

Trim Shipping Weight
Table C

Trim Configuration	2" (50 mm), 2½" (65 mm), 3" (80 mm), & 76 mm	4" (100 mm), 6" (150 mm), 8" (200 mm), & 165 mm
Wet Pilot Deluge	31 lbs (14 kg)	37 lbs (17 kg)
Dry Pilot Deluge	39 lbs (18 kg)	50 lbs (23 kg)
Electric Actuation Deluge	33 lbs (15 kg)	38 lbs (17 kg)

Friction Loss
Table D

Valve Size	Equivalent Length*		Cv gpm at 1 psi differential
	C = 120	C = 100	
2" (50mm)	4.4 ft (1,3 m)	3.1 ft (1,0 m)	101
2½" (65mm)	6.0 ft (1,8 m)	4.3 ft (1,3 m)	236
76mm	7.7 ft (2,3 m)	5.5 ft (1,7 m)	241
3" (80mm)	12.6 ft (3,8 m)	9.0 ft (2,7 m)	254
4" (100mm)	14 ft (4,3 m)	10 ft (3,0 m)	469
165mm	29.4 ft (9,0 m)	20.9 ft (6,4 m)	886
6" (150mm)	29.4 ft (9,0 m)	20.9 ft (6,4 m)	886
8" (200mm)	53.5 ft (16,3 m)	38.1 ft (11,6 m)	1516

*Note: Expressed in equivalent length of Schedule 40 pipe, based on Hazen & Williams formula.

Model DDX Wet-Pilot Line Trim

A wet-pilot line is a hydraulic type of detection/release system that can be used in conditioned (i.e. freeze protected) areas. Closed sprinklers or fixed-temperature-release pilot line detectors (PLD) are installed throughout the protected area on small diameter piping that contains water under pressure. The wet-pilot line is an extension of the release trim of the Model DDX Deluge Valve. Upon activation of a pilot line sprinkler or pilot line detector, pressure is released from the pilot line and therefore the piston/pushrod chamber. The Model DDX Deluge Valve will

open and deliver water to the open sprinklers, nozzles, or other discharge devices attached to the system piping in the protected area. Alarm devices are activated upon the flow of water into the sprinkler system piping. Wet-pilot trim is the basis on which dry-pilot line and electrical actuation systems are built; additional components are added to the wet-pilot trim for each of these systems. It is important to note that the length and height of wet-pilot lines is limited by the available system water pressure (refer to Figure 2 on page 4).

Model DDX Valve with Wet-Pilot Line Trim

Figure 1

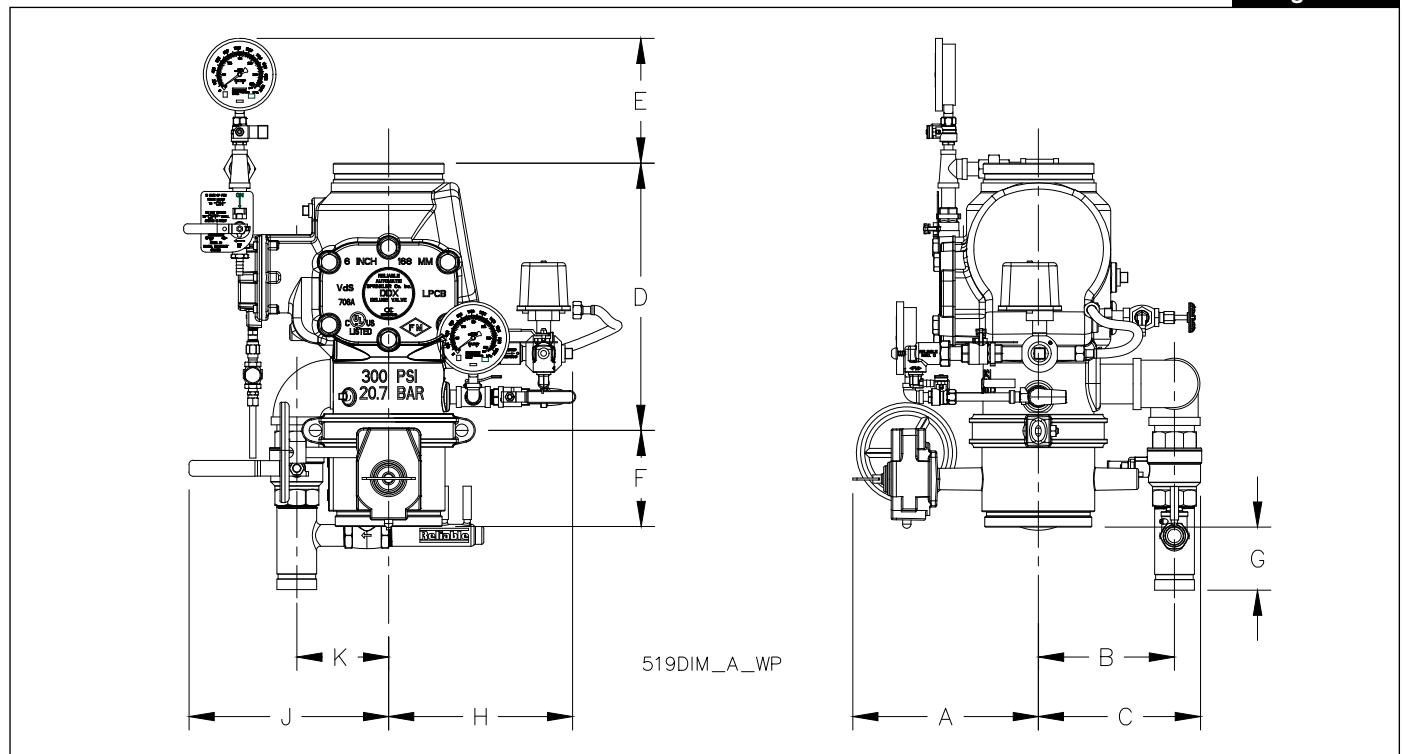

Model DDX Valve with Wet-Pilot Release Trim Dimensions

Table E

Nominal Pipe Size	Installation Dimensions in Inches (mm)										
	A	B	C	D ⁽¹⁾	D ⁽²⁾	E	F ⁽³⁾	G	H	J	K
2" (50mm)	8-1/2 (216)	7-3/4 (197)	9-1/8 (232)	12-1/2 (318)	NA	8-3/8 (213)	3-7/8 (98)	1-1/2 (38)	10 (254)	9-1/2 (241)	4 (102)
2-1/2" (65 mm), 3" (80 mm) & 76 mm	8-1/2 (216)	7-3/4 (197)	9-1/8 (232)	12-1/2 (318)	NA	8-3/8 (213)	3-7/8 (98)	1-3/8 (35)	9-7/8 (251)	9-1/2 (241)	3-7/8 (98)
4" (100 mm)	9-3/4 (248)	7-5/8 (194)	9-1/4 (235)	14 (356)	16 (406)	7-1/4 (184)	4-9/16 (116)	5-1/4 (133)	11 (279)	11-7/8 (301)	5-1/2 (140)
6" (150 mm) & 165 mm	11-1/8 (283)	8-1/8 (206)	9-3/4 (248)	16 (406)	19 (483)	6-7/8 (175)	5-7/8 (149)	3-3/4 (95)	11 (279)	12 (305)	5-1/2 (140)
8" (200 mm)	12-5/8 (321)	9 (229)	10-5/8 (270)	19-3/8 (492)	21-1/4 (540)	3-3/4 (95)	5-1/4 (134)	4-1/8 (105)	12-5/8 (321)	12 (305)	5-1/2 (140)

Notes:

1. End to end take out of Model DDX valve with grooved inlet.
2. End to end take out of Model DDX valve with flanged inlet where available (see page 1).
3. Not applicable to 76mm or 165mm systems, or systems using a flanged inlet Model DDX valve.

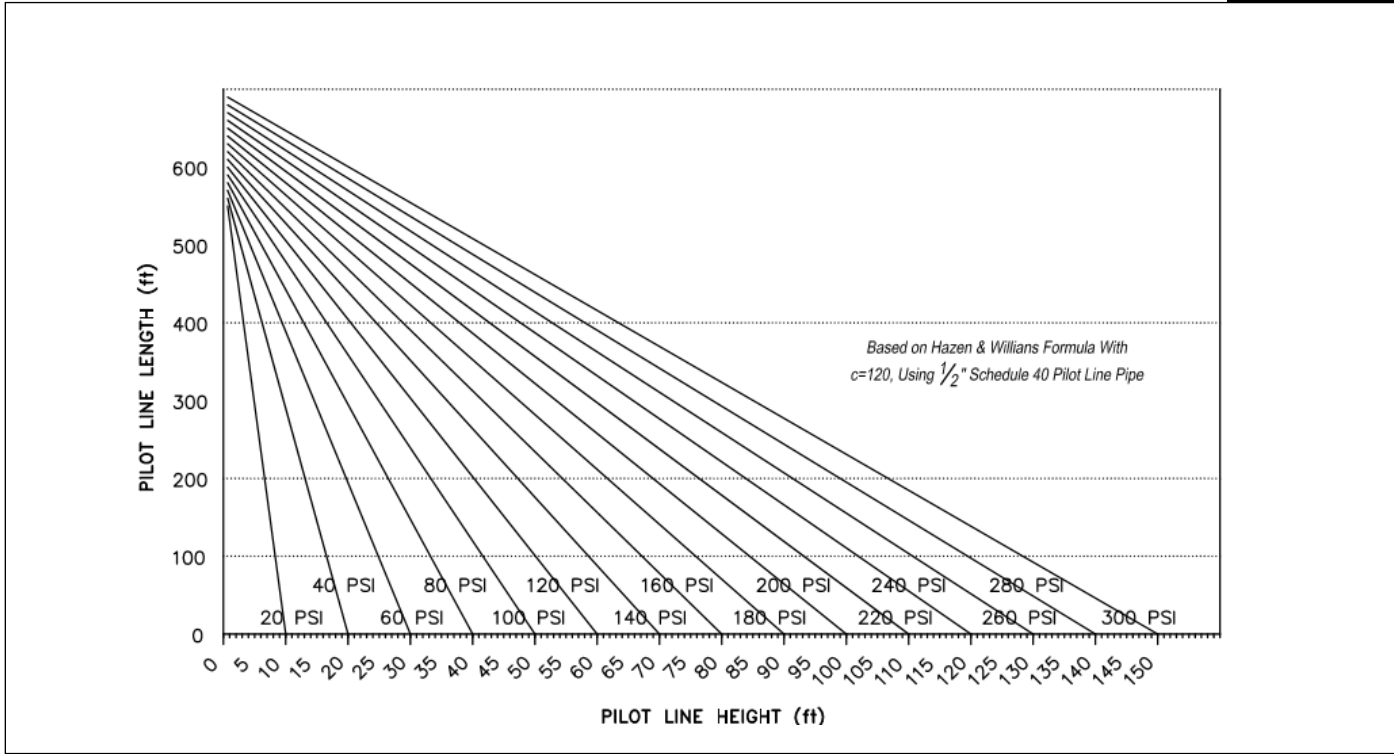

Dry Pilot Line Pneumatic Pressure

Table F

Water Pressure psi (bar)	Dry Pilot Line Pneumatic Pressure psi (bar)
Maximum	Not Less Than
20 (1.4)	8 (0.6)
30 (2.1)	10 (0.7)
50 (3.4)	12 (.8)
75 (5.2)	13 (.9)
100 (6.9)	15 (1.)
125 (8.6)	16 (1.1)
150 (10.3)	17 (1.2)
175 (12.1)	18 (1.2)
200 (13.8)	19 (1.3)
225 (15.5)	21 (1.4)
250 (17.2)	22 (1.5)
275 (19.0)	23 (1.6)
300 (20.7)	24 (1.7)

Notes:

- Supervisory air or nitrogen pressure should not exceed 30 psi (2.1 bar). Excess pressure may result in damage to the actuator.
- Fastest valve operation is achieved with supervisory air or nitrogen pressure indicated; however, pressure must never be less than the minimum specified in the table above.
- Air maintenance devices that maintain a constant pressure are recommended; however, if a tank-less compressor is used, the "compressor on" setting of the pressure switch must never be lower than the minimum pressure in the table above.

Model DDX Dry-Pilot Line Trim

Where freezing conditions exist, or where height/distance limits of wet-pilot lines are exceeded, a dry-pilot line can be used. A dry-pilot line is a pneumatic type of detection/release system that can be used in unconditioned areas. Closed sprinklers or fixed-temperature-release pilot line detectors (PLD) are installed throughout the protected area on small diameter piping that contains pressurized air or nitrogen.

A Reliable Model LP Dry-Pilot Actuator is installed on the outlet of the Model DDX Deluge Valve piston/pushrod chamber. This device provides a separation between the hydraulically pressurized pushrod chamber and the pneumatically pressurized pilot line. Pneumatic pressure in the dry-pilot line closes the Model LP Dry-Pilot Actuator maintaining hydraulic pressure in the pushrod chamber. The pneumatic pressure required to maintain the Model LP Dry-Pilot Actuator in the closed position is specified in Table F (page 4).

Upon activation of a pilot line sprinkler or pilot line detector, pneumatic pressure is released from the piping allowing the dry-pilot actuator to vent and release hydraulic pressure from the pushrod chamber. This allows the Model DDX Deluge Valve to open and deliver water to the open sprinklers, nozzles, or other discharge devices attached to the system piping in the protected area. Alarm devices are activated upon the flow of water into the sprinkler system piping. Pneumatic pressure in the dry-pilot line can be provided from a tank-mounted compressor, plant air system, nitrogen generator or nitrogen cylinders and must be maintained by a Reliable Model A listed pressure maintenance device. To prevent accidental system activation, pneumatic pressure is monitored by a means that will initiate a signal in the event of low pneumatic pressure due to sprinkler damage, pipe damage, or failure of the compressed gas system.

Model DDX Valve with Dry-Pilot Release Trim

Figure 3

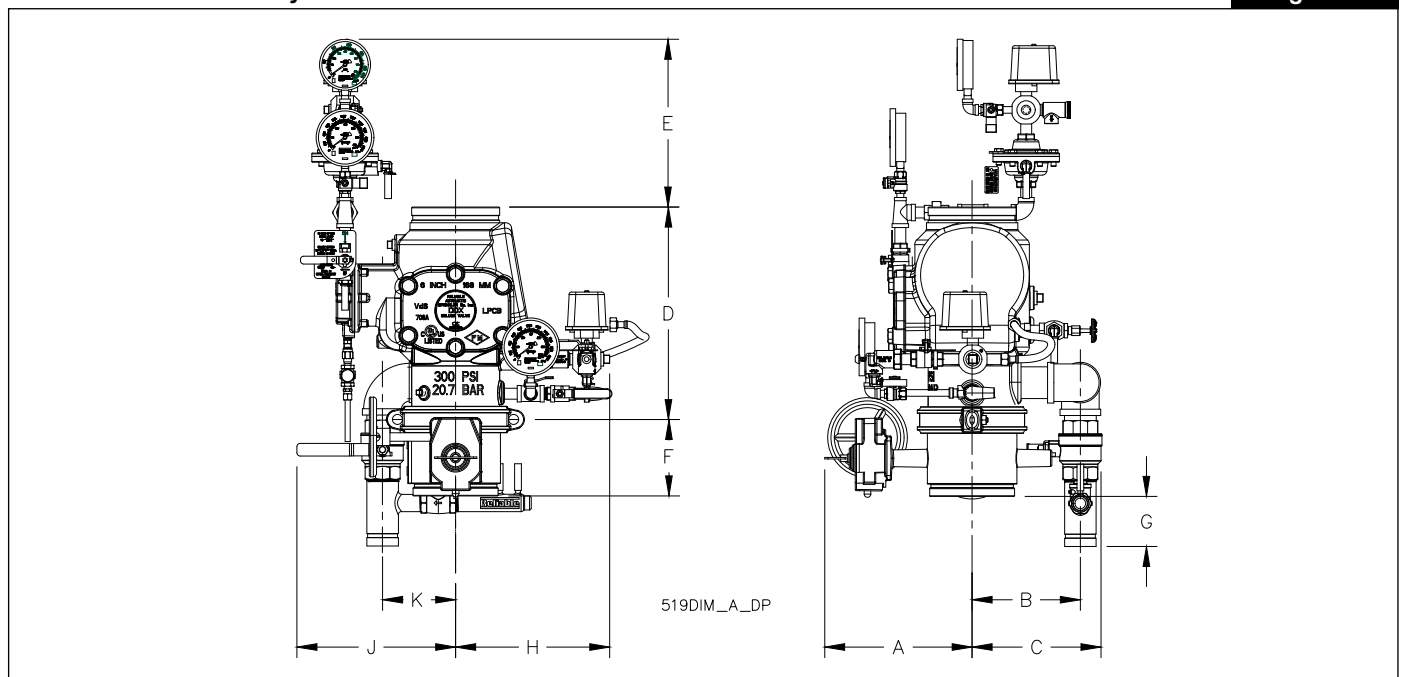

Model DDX Valve with Dry-Pilot Release Trim Dimensions

Table G

Nominal Pipe Size Inches (mm)	Installation Dimensions in Inches (mm)										
	A	B	C	D ⁽¹⁾	D ⁽²⁾	E	F ⁽³⁾	G	H	J	K
2" (50)	8-1/2 (216)	7-3/4 (197)	9-1/8 (232)	12-1/2 (318)	NA	13-3/4 (349)	3-7/8 (98)	1-1/2 (38)	10 (254)	9-1/2 (241)	4 (102)
2-1/2" (65), 3" (80), & 76mm	8-1/2 (216)	7-3/4 (197)	9-1/8 (232)	12-1/2 (318)	NA	13-3/4 (349)	3-7/8 (98)	1-3/8 (35)	9-7/8 (251)	9-1/2 (241)	3-7/8 (98)
4" (100)	9-3/4 (248)	7-5/8 (194)	9-1/4 (235)	14 (356)	16 (406)	12-1/2 (318)	4-9/16 (116)	5-1/4 (133)	11 (279)	11-7/8 (301)	5-1/2 (140)
6" (150) & 165mm	11-1/8 (283)	8-1/8 (206)	9-3/4 (248)	16 (406)	19 (483)	12-1/8 (308)	5-7/8 (149)	3-3/4 (95)	11 (279)	12 (305)	5-1/2 (140)
8" (200)	12-5/8 (321)	9 (229)	10-5/8 (270)	19-3/8 (492)	21-1/4 (540)	9 (229)	5-1/4 (134)	4-1/8 (105)	12-5/8 (321)	12 (305)	5-1/2 (140)

Notes:

- End to end take out of Model DDX valve with grooved inlet.
- End to end take out of Model DDX valve with flanged inlet where available (see page 1).
- Not applicable to 76mm or 165mm systems, or systems using a flanged inlet Model DDX valve.

Model DDX Electric Release Trim

Where system actuation by means of an approval detection and release system are desired, the electric release trim may be used. The solenoid valve in the DDX Electrical Actuation Trim maintains the hydraulic pressure in the piston/pushrod chamber. Upon receipt of a signal from the electric detection system, a release control panel energizes the solenoid valve.

Pressure is released from the piston/pushrod chamber allowing the Model DDX Deluge Valve to open and deliver water to the open sprinklers, nozzles, or other discharge devices attached to the system piping in the protected area. Alarm devices are activated upon the flow of water into the sprinkler system piping.

Model DDX Valve with Electric Release Trim

Figure 4

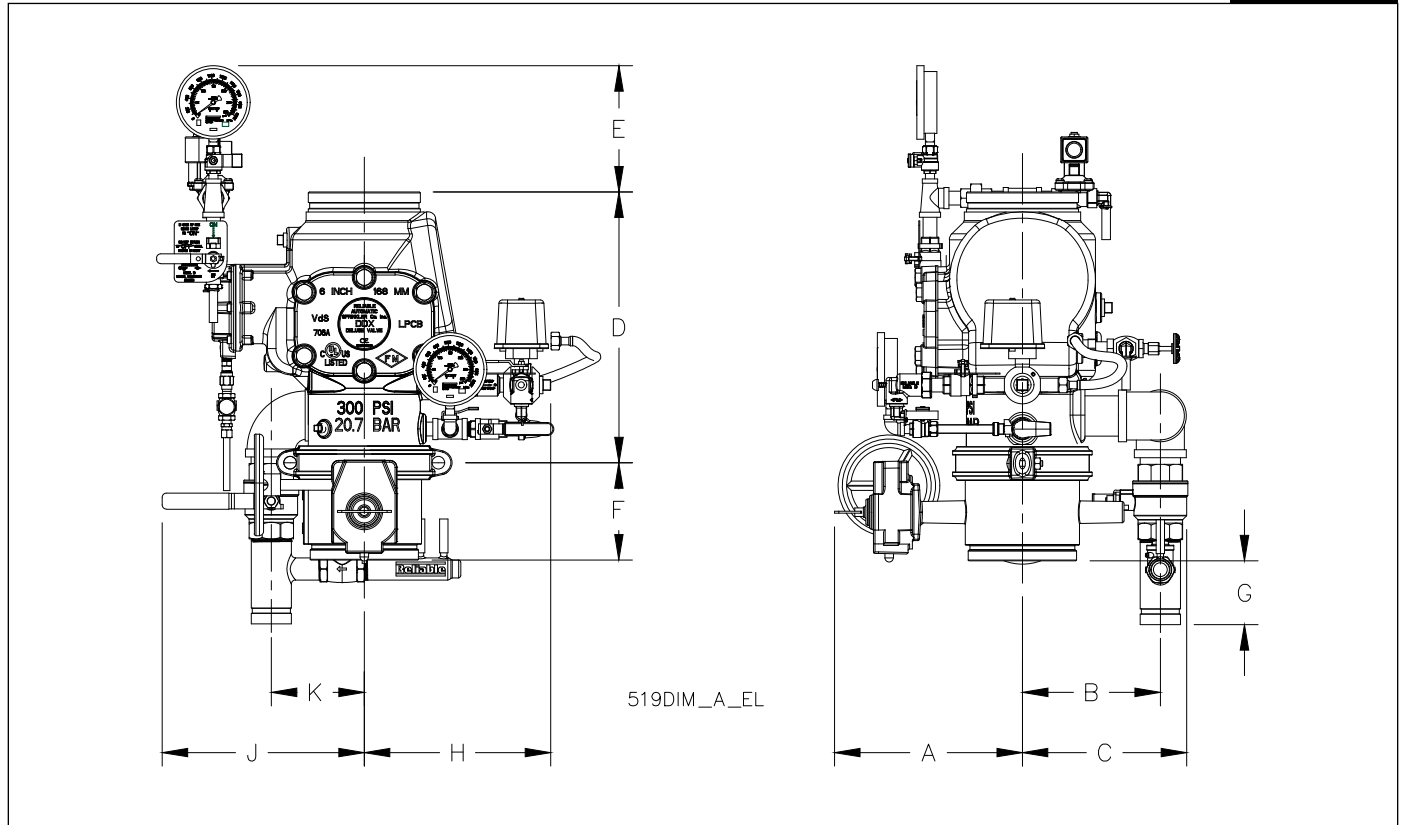

Model DDX Valve with Electric Release Trim Dimensions

Table H

Nominal Pipe Size Inches (mm)	Installation Dimensions in Inches (mm)										
	A	B	C	D ⁽¹⁾	D ⁽²⁾	E	F ⁽³⁾	G	H	J	K
2" (50)	8-1/2 (216)	7-3/4 (197)	9-1/8 (232)	12-1/2 (318)	NA	8-3/8 (213)	3-7/8 (98)	1-1/2 (38)	10 (254)	9-1/2 (241)	4 (102)
2-1/2" (65), 3" (80), & 76mm	8-1/2 (216)	7-3/4 (197)	9-1/8 (232)	12-1/2 (318)	NA	8-3/8 (213)	3-7/8 (98)	1-3/8 (35)	9-7/8 (251)	9-1/2 (241)	3-7/8 (98)
4" (100)	9-3/4 (248)	7-5/8 (194)	9-1/4 (235)	14 (356)	16 (406)	7-1/4 (184)	4-9/16 (116)	5-1/4 (133)	11 (279)	11-7/8 (301)	5-1/2 (140)
6" (150) & 165mm	11-1/8 (283)	8-1/8 (206)	9-3/4 (248)	16 (406)	19 (483)	6-7/8 (175)	5-7/8 (149)	3-3/4 (95)	11 (279)	12 (305)	5-1/2 (140)
8" (200)	12-5/8 (321)	9 (229)	10-5/8 (270)	19-3/8 (492)	21-1/4 (540)	3-3/4 (95)	5-1/4 (134)	4-1/8 (105)	12-5/8 (321)	12 (305)	5-1/2 (140)

Notes:

1. End to end take out of Model DDX valve with grooved inlet.
2. End to end take out of Model DDX valve with flanged inlet where available (see page 1).
3. Not applicable to 76mm or 165mm systems, or systems using a flanged inlet Model DDX valve.

Installation

The Model DDX valve should be installed in accordance with NFPA13, "Standard for the Installation of Sprinkler Systems," as well as the requirements of any authorities having jurisdiction. Failure to follow installation instructions and/or revisions to the trim arrangement of the valve may void the warranty and/or listing of the valve. Verify compatibility of the Model DDX valve's materials with the water supply and the environment where the valve will be installed prior to installation. The Model DDX valve must be installed in a location where the temperature is maintained as a minimum of 40°F (4°C). Heat tracing of the valve and/or trim is not permitted. Design and installation of the detection and release system must be performed in accordance with applicable NFPA standards and the authority having jurisdiction. Drain should be piped to a location that will avoid damage to property and/or injury to personnel.

Note: The Model DDX valve must only be installed in the vertical position with water moving up and through the valve.

Resetting Model DDX Deluge Valve Systems

- This procedure should only be performed by persons who are experienced and trained in the installation and operation of water-based fire protection systems.
- The fire protection system served by the deluge valve will be out of service until the reset procedure is completed.
- Notify any necessary authorities having jurisdiction and other affected personnel prior to placing the fire protection system out of service.
- Failure to follow this reset procedure can cause failure of the deluge valve, resulting in serious personal injury and property damage.

Please contact Reliable Technical Services at 1-800-557-2726 with any questions regarding this reset procedure.

1. Close the valve controlling water supply to the Deluge Valve and close the valve supplying hydraulic pressure to the piston/pushrod chamber.
2. Open main drain valve and drain system.
3. Open all drain valves and vents at low points throughout the system, closing them when flow of water has stopped. Open the emergency manual release valve.
4. Verify that the alarm line ball valve is open and push in the plunger of ball drip to verify that there is only atmospheric pressure inside the intermediate chamber of the deluge valve.
5. Push in and rotate external reset knob in the direction of the piston/pushrod chamber. This will rotate the lever and allow the clapper to reset.
6. Open the valve supplying hydraulic pressure to the piston/pushrod chamber and allow water to fill the pushrod chamber.

7. Proceed below based upon release trim style:

Wet Pilot Trim

7a. Slowly close the emergency manual release valve. Bleed the entire wet pilot line until all air is removed at the most remote pilot line detector (PLD)/sprinkler. Pressurization of the pilot line will cause the deluge valve to reset.

Dry Pilot Trim

7b. Close the emergency manual release valve causing water to flow through the pilot line actuator. When there is a solid flow of water into the drain manifold, apply compressed air or nitrogen through the pressure maintenance device to close the pilot line actuator. Pressurization of the pilot line actuator will cause the deluge valve to reset. Adjust the air or nitrogen supply pressure to the appropriate value as shown in Table F on page 4 as indicated on the system air pressure gauge.

Electric Actuation Trim

7c. Cause the solenoid valve to open by operating a detector or an electric manual emergency station. While water is flowing through the solenoid valve, reset the detection system, causing the solenoid valve to close. Slowly close the emergency manual release valve. Pressurization of the release trim will cause the deluge valve to reset. Refer to Bulletin 700, "Special Hazards & Special Systems" for details.

8. Slowly open the valve controlling water supply to the Deluge Valve, while simultaneously closing the main drain valve. Once the main drain valve is fully closed, ensure that the main control valve is fully open, and all alarm and supervisory switches are reset.

Note: The solenoid valve used in the assembly is available with either a 175 psi (12.1 bar) or 300 psi (20.7 bar) rating. See below for selection and specifications for the solenoid valve.

Caution: Repairs or disassembly of the solenoid valve should be done only by a trained technician. An improperly repaired or partially assembled solenoid valve could result in accidental operation of the valve, or failure of the valve to operate.

Standard Solenoid Valve Specifications:

Parker-Hannifin Model 73218BN4UNLVN0C111C2

Rated working pressure: 175 psi (12.1 bar)

Voltage: 24 VDC

Power: 10 Watts

Current: 0.41 Amps Holding

Enclosure Coil: NEMA 4X

Pipe Size: ½" NPT Female

Cv Factor: 4.0

Alternate Solenoid Valve Specifications:

Parker-Hannifin Model 73212BN4TNLVN0C322C2

Rated working pressure: 300 psi (20.7 bar)

Voltage: 24 VDC

Power: 22 Watts

Current: 0.83 Amps Holding

Enclosure Coil: NEMA 4X

Pipe Size: ½" NPT Female

Cv Factor: 2.8

Model DDX Valve Components

Figure 5

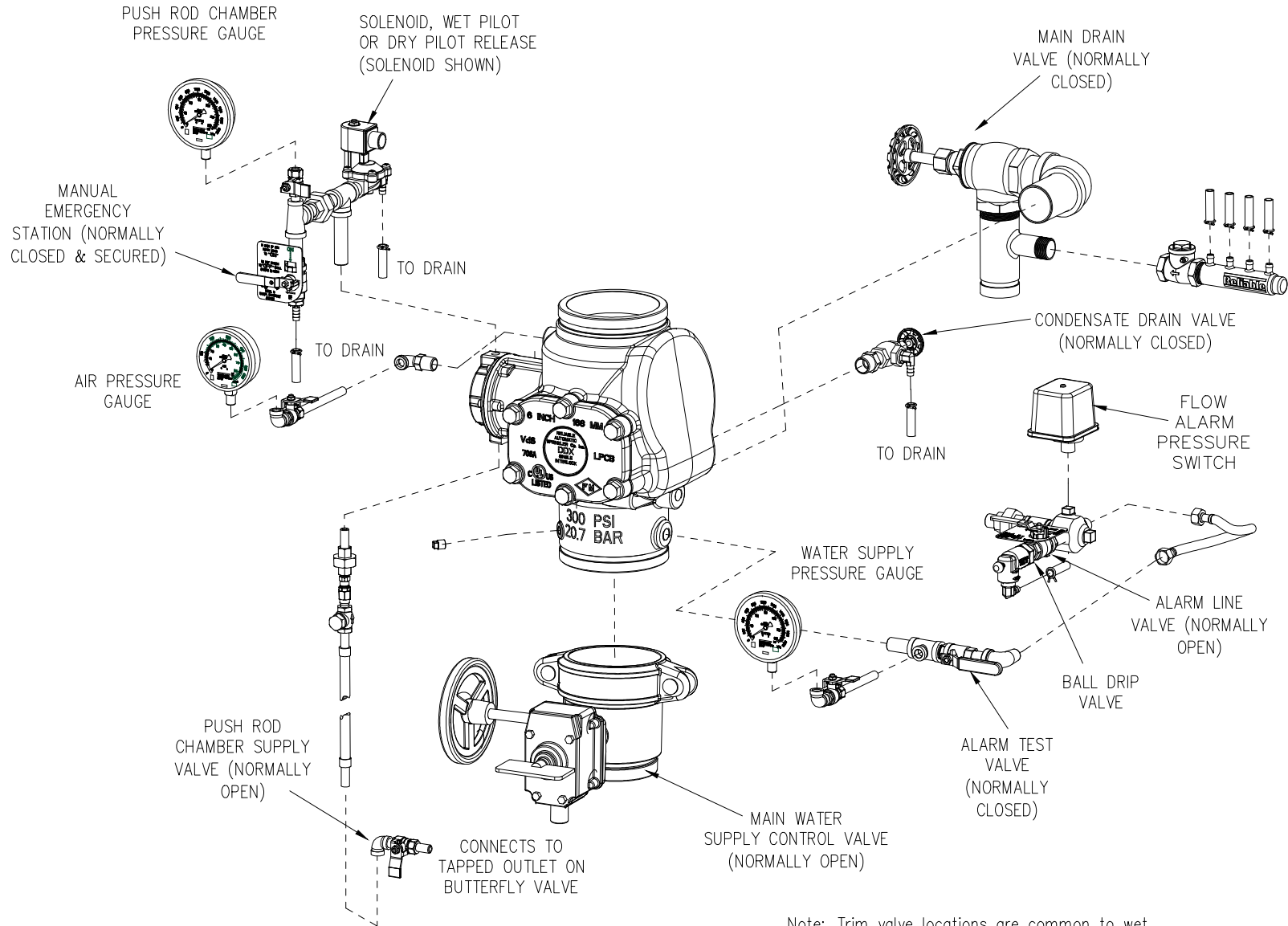

519EXP_A

Note: Trim valve locations are common to wet pilot line, dry pilot line, and electric release systems.

Inspection and Testing

1. Water supply — Confirm that valves controlling water supply to the Deluge Valve are opened fully and properly monitored.
2. Alarm line — Confirm that the alarm line valve is open and remains in this position.
3. Other trim valves — Confirm that the pushrod chamber supply valve is open, as well as all pressure gauge valves. The main drain valve, condensate drain valve, and alarm test valve should be closed.
4. Ball drip valve — Push in on the plunger to be sure ball check is off its seat. If no water appears, the Deluge Valve water seat is tight. Inspect the bleed hole on the underside of the pushrod chamber for leakage.
5. Dry pilot trim — Inspect air pressure for conformance to Table A.
6. Releasing device — Check outlet of the releasing device (i.e., the dry pilot line actuator, solenoid valve, or the hydraulic manual emergency station) for leakage. Also verify that tubing drain lines from releasing devices are not pinched or crushed which could prevent proper releasing of the Deluge Valve.
7. Testing alarms — Open the alarm test valve permitting water from the supply to flow to the electric sprinkler alarm switch and to the mechanical sprinkler alarm (water motor). After testing, close this valve securely. Push in on the plunger of ball drip valve until all water has drained from the alarm line.
8. Operational test — Open the Model B Manual Emergency Station, or alternatively, operate the detection system.
Note: AN OPERATIONAL TEST WILL CAUSE THE DELUGE VALVE TO OPEN AND FLOW WATER INTO THE SPRINKLER SYSTEM.
9. Secure the Model B Manual Emergency Station in the OFF position with nylon tie after Deluge Valve is reset.

Testing Detection System Without Operating Deluge Valve

1. Close the valve controlling water supply to the deluge valve and open the main drain valve.
2. Verify that valve supplying hydraulic pressure to the piston/pushrod chamber is open, allowing water to enter the pushrod chamber.
3. Operate the pilot line, dry pilot line, or electrical detection system.
4. Operation of the detection system must result in a sudden drop of water pressure in the pushrod chamber, as indicated by the water supply pressure gauge on the hydraulic release trim.
5. Reset the valve per the reset instructions.

Maintenance

The owner is responsible for maintaining the fire protection system in proper operating condition. Any system maintenance or testing that involves placing a control valve or detection/control system out of service may eliminate the fire protection that is provided by the fire protection system.

The Reliable Model DDX valve and associated equipment shall periodically be given a thorough inspection and test. NFPA 25, "Inspection, Testing, and Maintenance of Water Based Fire Protection Systems," provides minimum maintenance requirements. System components shall be tested, operated, cleaned, and inspected at least annually, and parts replaced as required. Replace any components found to be corroded, damaged, worn, or non-operable. Increase the frequency of inspections when the valve is exposed to corrosive conditions or chemicals that could impact materials or operation of the assembly.

If face plate is removed during maintenance, torque face plate bolts to the following values during re-installation:

- 35 ft-lbs. (47 N-m) for 2" through 4" valves
- 70 ft-lbs. (95 N-m) for 6"-8" valves

Troubleshooting

1. Mechanical sprinkler alarm not operating: This is most likely caused by a clogged screen in the strainer of the water motor. Proceed as follows: Remove plug from the strainer. Remove and clean the screen. Replace the screen and the plug, and then tighten securely (Ref. Bulletin 613).
2. Water leaking from Ball Drip. This can be caused by either a water column on top of the clapper or a supply water leakage.
 - a. Leakage due to water column. This condition is caused by leakage past the clapper seal assembly. Be sure the clapper seal and seat are free of any type of debris or damage. If necessary, follow steps below to replace the seal assembly and/or seat.
 - b. Supply water leakage. This condition is caused by leakage past the lower seat O-ring. Follow steps below for inspection and/or replacement of lower seat O-ring.

Repair Procedures - Model DDX Deluge Valve

The following section provides instructions to correct both conditions:

1. Disable detection system.
2. Shut down the valve controlling the water supply to the Deluge Valve and open the main drain valve. Open the condensate drain valve. Close the pushrod chamber supply valve and open the Model B Manual Emergency Station.
3. Remove the Deluge Valve front (handhold) cover and inspect the seat, clapper, and seal assembly for damage. If inspection indicates damage to the seal assembly, replace as follows:
4. Remove the bumpstop nuts and remove the seal assembly. Install a new seal assembly and thread the bumpstop nuts onto the threaded studs of the seal assembly. Tighten finger tight plus $\frac{1}{4}$ to $\frac{1}{2}$ turn.
5. If inspection indicates damage to the clapper, proceed to step 6.
6. At the rear of the valve, disconnect the condensate drain trim section starting with the elbow connector. Then remove the $\frac{1}{4}$ " globe valve, followed by the $\frac{3}{4}$ "x $\frac{1}{4}$ " reducing bushing. Remove the retaining rings from the clapper hinge pin, push the hinge through the condensate drain opening and remove the clapper subassembly. Install a new clapper subassembly in the reverse order making sure the clapper spacers are in their proper position.
7. If the seat is damaged, or it is suspected that the leakage is through the seat O-rings, proceed to step 8.
8. Using Reliable P/N 6881603000 Seat Wrench for 2" (50mm), 2½" (65mm), 76mm and 3" (80mm) valve sizes, Reliable P/N 6881604000 for 4" (100mm) valve size, Reliable P/N 6881606000 for the 6" (150mm) and 165mm valve sizes or Reliable P/N 6881608000 Seat Wrench for 8" (200mm) valve size, remove the seat by unscrewing. This will loosen the seat-clapper-mounting ring subassembly. Reach into the valve and grasp the seat and remove it from the valve. Then remove the clapper-mounting ring subassembly from the valve. Visually examine all components of the seat-clapper-mounting ring subassembly and replace any component that appears damaged. New O-rings should always be used for reassembly.
9. Reassembly: clean the bore of the valve body. Lubricate the bore with O-ring grease. Lubricate and install the O-rings onto the seat. Lubricate and install the mounting ring O-ring into the body (8" (200mm) valve size only). Insert the clapper-mounting ring subassembly into the handhold opening of the Deluge Valve using caution to not damage or dislodge the mounting ring O-ring (8" (200mm) valve size only). Align the mounting ring so that the Lever is near the pushrod and the mounting ring "ears" are between the tabs of the valve body. Insert the seat into the valve body and through the clapper-mounting ring subassembly. Start to tread the seat into the body by hand, then tighten the seat with the seat wrench until it bottoms out on the mounting ring. Verify that the seat-clapper-mounting ring subassembly is in the fully down position between the tabs of the body, and check to see that the lever lines up with the pushrod. Reassemble the handhold cover and set up the Model DDX Deluge Valve as per the section "Resetting Model DDX Deluge Valve Systems".

Pushrod Chamber Maintenance - Model DDX Deluge Valve

A small bleed hole is located on the underside of the pushrod chamber. Water leakage from the bleed hole can be caused by a ruptured pushrod diaphragm:

- a) Disable detection system.
- b) Shut down the valve controlling water supply to the Deluge Valve. Relieve the inlet pressure by opening the main drain valve. Close the pushrod chamber supply valve and open the Model B Manual Emergency Station.
- c) Remove the trim at the unions nearest to the pushrod chamber cover.
- d) Take the pushrod chamber cover off by removing the six retaining screws.
- e) Visually inspect the pushrod chamber cover and piston to determine what could have damaged the diaphragm and then correct. Install a new diaphragm.
Note: The diaphragm has two different surfaces; it is not bi-directional and will fail if installed backwards. Roll the diaphragm so that the smooth surface (the pressure side) conforms to the inside of the pushrod chamber cover and the fabric side engages the pushrod.
- f) Reassemble the six retaining screws with an installation torque of 15 foot-pounds in a star pattern.
- g) Set up the Model DDX Deluge Valve as per the section "Resetting Model DDX Deluge Valve Systems."

Draining Excess/Condensate Water from the System

1. Notify the owner and monitoring company that maintenance is being performed on the system.
2. Close the main water control valve.
3. Open the Main Drain Valve.
4. Open the Condensate Drain Valve until all water has drained.
5. Close Condensate Drain Valve.
6. Partially open the Main Water Control Valve.
7. Slowly close the Main Drain Valve.
8. Fully open the Main Water Control Valve.
9. Notify the owner and monitoring company that the system has been returned to service.

Listings and Approvals

(Only when used with Reliable Trim Sets)

1. Listed by Underwriters Laboratories, Inc. an dUL certified for Canada (cULus).
2. Certified by FM Approvals (FM).
3. Loss Prevention Certification Board (LPCB) [4" (100mm), 6" (150mm), and 8" (200mm) sizes only]
4. VdS Schadenverhütung GmbH (VdS)
5. EN Certificates (CE).

Guarantee

For Reliable Automatic Sprinkler Co., Inc. guarantee, terms, and conditions, visit www.reliablesprinkler.com.

Ordering Information

Specify:

Valve Model: DDX

Valve Size: [2" (50mm)] [2-1/2" (65mm)] [76mm]
[3" (80mm)] [4" (100mm)] [6" (150mm)] [165mm]
[8" (200mm)]

End Connection Configuration (see Table A):

[Groove/Groove] [Flange/Groove] [Flange/Flange]

Note: 2", 2-1/2", 3", and 76mm valves are available only with grooved ends.

Operational Trim: [Wet-Pilot Release]

[Dry-Pilot Release] [Electric Release 175psi (12,1 bar)] [Electric Release 300psi (20,7 bar)]

Trim Configuration: [Loose Trim] [Segmentally Assembled Trim] [Fully Assembled Trim w/o Water Supply Control Valve] [Fully Assembled w/ Water Supply Control Valve]

Water Pressure Gauges: 0-300 psi (20,7 bar) or 0-600 psi (41,4 bar)

Service Kits

Service kits are available for routine servicing of the valve (reference Assembly Drawings on website). Service kits for the Model DDX Deluge Valve include the following components:

- Clapper Seal Assembly (item 8)
- Cover Gasket (item 9)
- Bumpstop(s) (item 10)
- Push rod chamber diaphragm (item 18)
- Grease (item 42)

2", 2-1/2", and 3" Model DDX Service Kit: PN 6501200R03

4" Model DDX Service Kit: PN 6501200R04

6" Model DDX Service Kit: PN 6501200R05

8" Model DDX Service Kit: PN 6501200R06

Note: Early generation 4" and 6" Model DDX valves utilize a drop-in brass clapper. Service kits for early Model DDX valves are as follows:

4" Early generation DDX Deluge Valve Service Kit: PN 6501200R07

6" Early generation DDX Deluge Valve Service Kit: PN 6501200R08