



**Model RFC49*plus* & RFC49LL*plus***  
**Residential Sprinklers**  
 Flat Concealed Pendent  
 cULus Listed

## Features

- cULus Listed as Residential Sprinklers
- 1-inch (25mm) cover plate adjustment
- Low water flow requirements
- Ordinary and Intermediate temperature options

## Product Description

Model RFC49*plus* residential sprinklers are flat cover plate, concealed pendent sprinklers intended for installation in accordance with NFPA 13, NFPA 13R, or NFPA 13D. The sprinklers are cULus Listed as Residential Sprinklers in accordance with UL 199.

Model RFC49*plus* sprinklers are offered with either a 165°F (74°C) or 212°F (100°C) temperature rated fusible-link operating element. Sprinklers with a 165°F (74°C) temperature rating are ordinary temperature classification and are listed for use with a 135°F (57°C) temperature rated cover plate. Sprinklers with a 212°F (100°C) temperature rating are intermediate temperature classification and are listed for use with a 165°F (74°C) temperature rated cover plate.

Model RFC49*plus* sprinklers are installed with a Model G5 cover plate. Model G5 cover plates are installed by pushing the cover plate into the cup and turning in the clockwise direction until it is tight against the ceiling. Model RFC49*plus* and RFC49LL*plus* sprinklers allow 1-inch (25 mm) of cover plate adjustment. Model G5 cover plates are available in a variety of standard and special application finishes as listed in Table C, as well as a variety of custom finishes indicated on technical bulletin 203.



**Table A**

Sprinkler Model	Nominal K-Factor gpm/psi <sup>1/2</sup> (l/min/bar <sup>1/2</sup> )	Max. Coverage Area ft x ft (m x m)	Listings & Approvals	Sprinkler Identification Number (SIN)
RFC49 <i>plus</i>	4.9 (71)	20 x 20 (6.1 x 6.1)	cULus	R401
RFC49LL <i>plus</i>	4.9 (71)	20 x 20 (6.1 x 6.1)	cULus, LL	R402

cULus: cULus Listed as Residential Sprinklers to UL199, Automatic Sprinklers for Fire-Protection Service.  
 LL: cULus Certified for Health Effects to NSF/ANSI Standard 61 Annex G (Less than 0.25% Lead content).

**Technical Specifications**

**Style:** Flat Concealed Pendant  
**Threads:** 1/2" NPT or ISO 7-1R1/2  
**Nominal K-Factor:** 4.9 (71 metric)  
**Max. Working Pressure:** 175 psi (12 bar)  
**Min. Spacing:** 8 ft. (2.4 m)

**Material Specifications**

**Thermal Sensor:** Nickel Alloy Solder Link  
**Sprinkler Body:** Brass Alloy  
**Levers:** Bronze Alloy  
**Yoke:** Brass Alloy  
**Sealing Assembly:** Nickel Alloy with PTFE  
**Load Screw:** Bronze Alloy  
**Towers:** Copper Alloy  
**Pins:** Stainless Steel  
**Deflector:** Copper Alloy  
**Cup:** Steel

**Cover Plate Finishes**

(See Table C)

**Sensitivity**

Fast-response

**Temperature Rating**

Ordinary:  
 165°F (74°C) sprinkler  
 [135°F (57°C) cover plate]  
 Intermediate:  
 212°F (100°C) sprinkler  
 [165°F (74°C) cover plate]

**Cover Plate**

Model G5 Cover Plate

**Sprinkler Wrench**

Model W10  
 Model W11 (limited use plastic)

**Listings and Approvals**

cULus Listed to UL 199  
 cULus Certified for Health Effects to NSF/ANSI  
 Standard 61 Annex G (RFC49LL*plus* only)



Model RFC49*plus* & RFC49LL*plus* Sprinkler Components and Dimensions

Figure 1

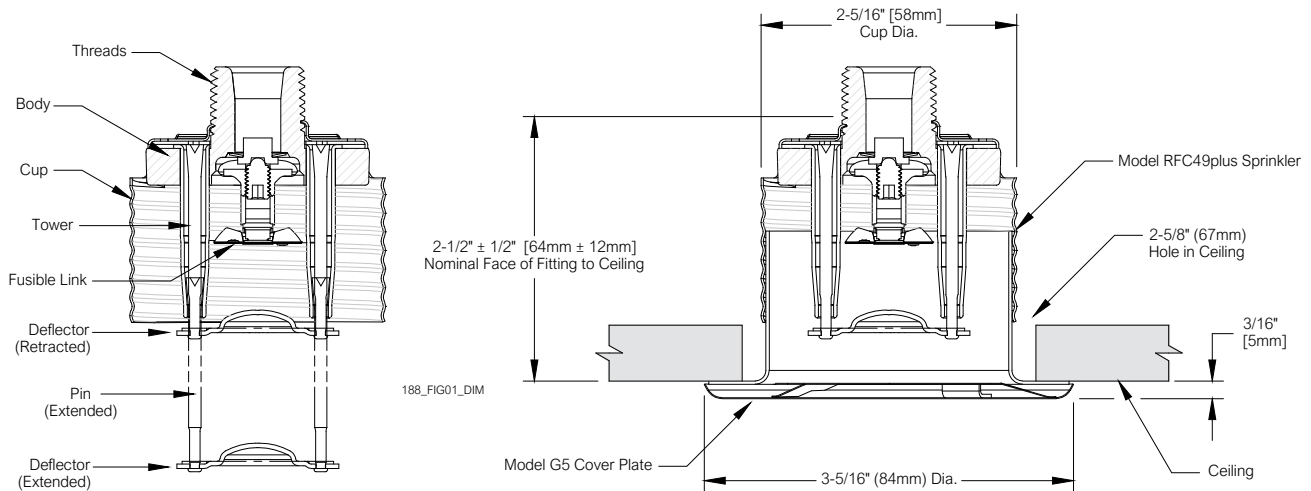

Model RFC49*plus* & RFC49LL*plus* Sprinkler Hydraulic Design Criteria

Table B

Minimum Flow and Residual Pressure <sup>(1)</sup>		
Max. Coverage Area <sup>(2)</sup> ft x ft (m x m)	Flow gpm (l/min)	Pressure psi (bar)
16 x 16 (4.9 x 4.9)	13 (49.0)	7.0 (0.48)
18 x 18 (5.5 x 5.5)	17 (64.3)	12.0 (0.83)
20 x 20 (6.1 x 6.1)	20 (75.7)	16.7 (1.15)

**Notes:**

- For NFPA 13 installations the flow per sprinkler must be the greater of: (1) the flow listed in Table B above and (2) the flow required to achieve a minimum design density of 0.1 gpm/sq ft over the design area of the sprinkler.
- For coverage area dimensions less than those listed above, use the minimum required flow for the next larger max. coverage area listed.

## Cover Plate Finishes<sup>(1)</sup>

**Table C**

Standard Finishes	Special Application Finishes		
White Polyester	Off White Paint	Black Paint	Raw Brass
Chrome Plated	Bright Brass	Finished Bronze	Custom Color Paint <sup>(3)</sup>
	Satin Chrome	Stainless Steel Clad <sup>(2)</sup>	Custom Printed

### Notes:

1. Paint or any other coating applied over the factory finish will void all approvals and warranties.
2. Stainless steel clad cover plates are Type 316 Stainless Steel on the finished side and Copper Alloy on the back side. Cover plates are not listed or approved as corrosion resistant.
3. Custom color paint is semi-gloss, unless specified otherwise.

## Installation Dimensions

**Table D**

Sprinkler Model	Cover Plate Model	Cover Plate Diameter inch (mm)	Recommended Hole Diameter in Ceiling inch (mm)	Cover Plate Adjustment inch (mm)	Min. to Max. Face of Fitting to Ceiling <sup>(1)</sup> inch (mm)	Min. to Max. Dropped Deflector Distance below Ceiling inch (mm)	Cover Plate Temperature Rating
RFC49 <i>plus</i> , RFC49LL <i>plus</i>	G5	3-5/16 (84)	2-5/8 (67)	1 (25)	2 to 3 (51 to 76)	1/4 to 1-1/4 (6 to 32)	135°F <sup>(2)</sup> (57°C) or 165°F <sup>(3)</sup> (74°C)

### Notes:

1. Face of fitting to ceiling dimensions are based on a nominal thread make up. Verify dimensions based on fitting and thread sealing method prior to installation.
2. For use with 165°F (74°C) temperature rated sprinklers where the maximum ceiling temperature does not exceed 100°F (38°C).
3. For use with 212°F (100°C) temperature rated sprinklers where the maximum ceiling temperature does not exceed 150°F (66°C).

## Installation

Model RFC49*plus* sprinklers are intended to be installed in accordance with NFPA 13, NFPA 13R, or NFPA 13D, as well as the requirements of applicable authorities having jurisdiction. Model RFC49*plus* sprinklers must not be installed in ceilings with positive pressure in the space above. Ensure that the four slots in the cup are open and unobstructed following installation. Model RFC49*plus* sprinklers are shipped with a wrench-able protective cap that should remain on the sprinkler until the sprinkler system is placed in service following construction.

Model RFC49*plus* sprinklers can be installed without removing the wrench-able protective cap using the Model W10 wrench. The Model W11 wrench is available for limited use in replacing RFC49*plus* sprinklers. The wrench-able protective cap must be temporarily removed when the W11 wrench is used. The use of any other wrench to install or remove Model RFC49*plus* sprinklers is not permitted and may damage the sprinkler. Fully insert the Model W10 wrench over the cap until it reaches the bottom of the cup. Do not wrench any other part of the sprinkler/cup assembly. The Model W10 and W11 wrenches are designed to be used with a standard 1/2" square drive ratchet. Tighten the sprinkler into the fitting after applying a PTFE based thread sealant to the sprinkler threads. Recommended installation torque for iron pipe fittings is 8 to 18 ft-lbs (11 to 24 N·m).

**Note:** When used with gasketed fittings, follow fitting manufacturer's installation instructions regarding tightening to achieve a leak-free connection.

Do not exceed the maximum recommended torque. Exceeding the maximum recommended torque may cause leakage or impairment of the sprinkler. Use care when inserting or removing the wrench from the sprinkler to avoid damage to the sprinkler.

Install the cover plate by hand by pushing the cover plate into the cup and turning the cover in the clockwise direction until it is tight against the ceiling.

## Installation Wrenches



**Model W10**

For use with Model RFC49*plus* sprinklers



**Model W11 (Service/ Spare Head Cabinet Wrench)**

High-strength plastic wrench for limited (emergency) use with Model RFC49*plus* sprinklers without wrench-able cap installed. Meets NFPA requirements for sprinkler wrench on premises.

## Maintenance

Model RFC49*plus* sprinklers should be inspected and the sprinkler system maintained in accordance with NFPA 25. Do not clean sprinklers with soap and water, ammonia or any other cleaning fluids. Remove dust by gentle vacuuming. Replace any sprinkler cover plate assembly which has been painted (other than factory applied) or damaged in any way. A stock of spare sprinklers should be maintained to allow quick replacement of damaged or operated sprinklers. Prior to installation, sprinklers should be maintained in the original cartons and packaging until used to minimize the potential for damage to sprinklers that would cause improper operation or non-operation.

## Guarantee

For the Reliable Automatic Sprinkler Co., Inc. guarantee, terms, and conditions, visit [www.reliablesprinkler.com](http://www.reliablesprinkler.com).

## Listings and Approvals

Listed by Underwriters Laboratories, Inc. and UL Certified for Canada to UL 199, Automatic Sprinklers for Fire-protection Service (cULus).

Certified by Underwriters Laboratories, Inc. and Underwriters Laboratories of Canada for Health Effects to NSF/ANSI Standard 61 Annex G (LL) (RFC49LL*plus* only).

## Ordering Information

Specify the following when ordering.

### Model

- RFC49*plus*
- RFC49LL*plus*

### Temperature Rating

- 165°F (74°C)
- 212°F (100°C)

### Cover Plate

- G5 (see Table C for finishes)

### Sprinkler Wrench

- Model W10
- Model W11 (limited use plastic)