

Reliable®

Model MV Medium Velocity Directional Spray Nozzles

cULus Listed
FM Approved

Features

- Non-automatic fixed pattern
- Solid cone discharge
- Seven orifice sizes
- Eight discharge angles

Product Description

The Reliable Model MV Medium Velocity Water Spray Nozzles are cULus Listed non-automatic, open nozzles, designed for directional spray applications in fixed fire protection systems. The nozzle has an internal deflector that discharges water in a directional cone shaped pattern and produces a small droplet size.

The nozzles are designed to apply water to exposed vertical, horizontal, curved, and irregular shaped surfaces. The MV nozzle is available in several combinations of orifice size and spray angles (as shown in Table A), and is commonly used in deluge systems for special hazard fire protection applications.

Model MV nozzles are available in unfinished brass or Electroless Nickel PTFE (ENT) plating. The nozzles are cULus Listed and FM Approved as corrosion resistant when ordered with ENT finish. Optional blow-off plugs can be used to prevent foreign materials from entering the water way of the nozzle. Blow-off plugs have an identification mark with respect to the K-factor.

Document Guide

	Page #
Notes on Spray Nozzle Graphs	2
Nozzle Set at 0° Orientation	3-6
Nozzle Set at 30° Orientation	7-10
Nozzle Set at 45° Orientation	11-14
Nozzle Set at 60° Orientation	15-18
Nozzle Set at 90° Orientation	19-22
Nozzle Set at 120° Orientation	23-26
Nozzle Set at 135° Orientation	27-30
Nozzle Set at 150° Orientation	31-34
Nozzle Set at 180° Orientation	35-38
Installation, Maintenance, Guarantee, Ordering Information	39

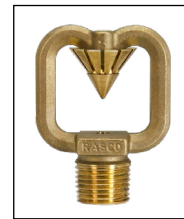

65° Spray
Nozzle



80° Spray
Nozzle



95° Spray
Nozzle



110° Spray
Nozzle



125° Spray
Nozzle



140° Spray
Nozzle



160° Spray
Nozzle



180° Spray
Nozzle

Model MV Summary

Table A

Model	Material	Finish	Available K-factor (Nominal) gpm/psi ^{1/2} (L/min/bar ^{1/2})	Orifice Diameter in. (mm)	Available Nozzle Angle
MV	Brass	Brass (Unfinished) ENT	1.2 (17)	.202 (5.13)	65°
			1.8 (26)	.250 (6.35)	80°
			2.3 (33)	.282 (7.16)	95°
			3.0 (43)	.325 (8.26)	110°
			4.1 (59)	.380 (9.65)	125°
			5.6 (80)	.446 (11.32)	140°
			7.2 (104)	.503 (12.78)	160°
					180°

Note: Each nozzle size (K-factor) is available in all nozzle deflector angles.

Model MV Medium Velocity Water Spray Nozzle

Technical Specifications

Style: Open Nozzle

Threads: ½" NPT or ISO 7-1 R1/2

Max. Working Pressure: 175psi (12bar)

Nominal K-factor, gpm/psi^{1/2} (L/min/bar^{1/2})

1.2 (17), 1.8 (26), 2.3 (33), 3.0 (43), 4.1 (59), 5.6 (80), 7.2 (104)

Nozzle Angle

65°, 80°, 95°, 110°, 125°, 140°, 160°, 180°

Material Specifications

Frame: Brass

Deflector Pin: Brass

Deflector: Brass

Blow-off Plug: Elastomer

Finish

Brass (Unfinished), ENT

Accessories

Blow-off Plug

Listings & Approvals

UL Listed

FM Approved



Model MV Nozzle Components and Dimensions

Figure 1

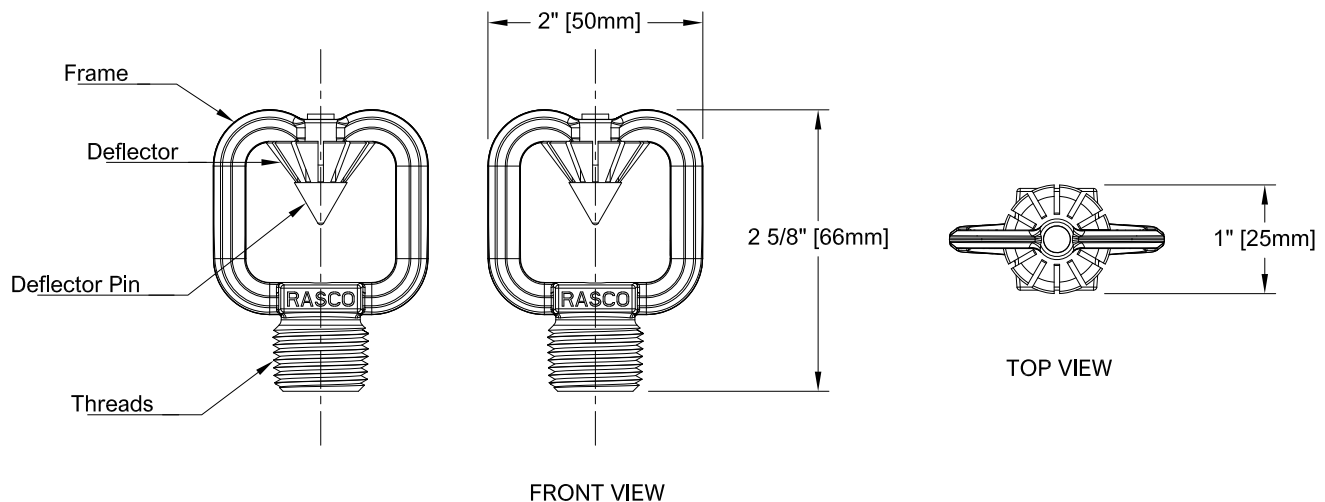

Notes for Figures 2 through 73 on the following pages:

- Nozzles may be oriented in any position necessary to protect the hazard.
- The graphs depict the spray pattern of eight (8) different nozzle angles when installed at nine (9) different fixed angles, with 0° fixed angle being straight down, 90° being horizontal, and 180° being straight up. It is assumed that the user will select the fixed angle first, and then select the appropriate nozzle angle.
- The spray pattern shown is for discharge pressures between 20 and 60 psi (1.4 and 4.1 bar) for all nozzle orifice sizes.
- The transition distance provided is the distance away from the nozzle where the water trajectory transitions from momentum (water pressure driven) to gravity driven. At this point (depending on the orientation of the nozzle), the coverage area may transition away from a circle. **Note: This information is provided for reference only and is not considered a part of the MV nozzle FM Approval.**
- Use of the nozzle beyond the transition distance is permitted provided the shape of the coverage area is considered.
- The spray patterns were obtained from tests performed in still air. Design of a water spray system for outdoor applications must consider the possible effects of wind on the discharge pattern.
- Obstructions affecting the spray pattern of the nozzle must also be considered.

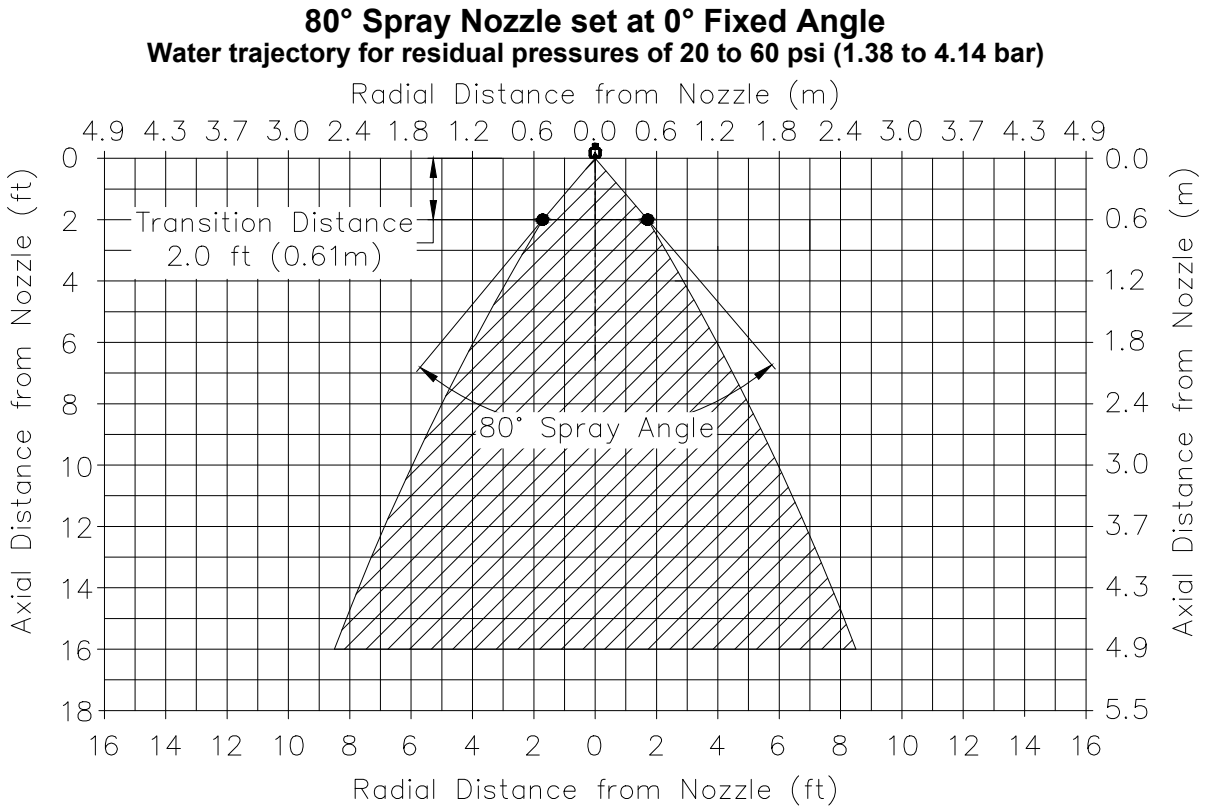
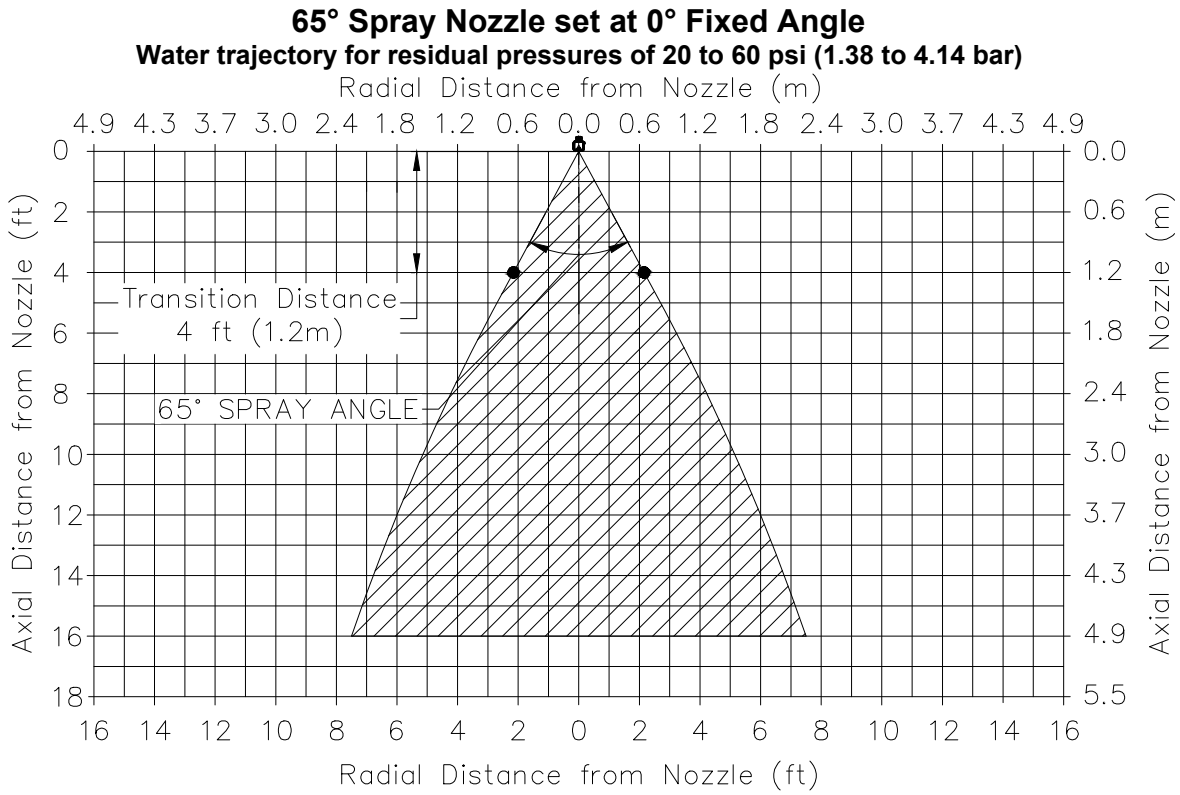

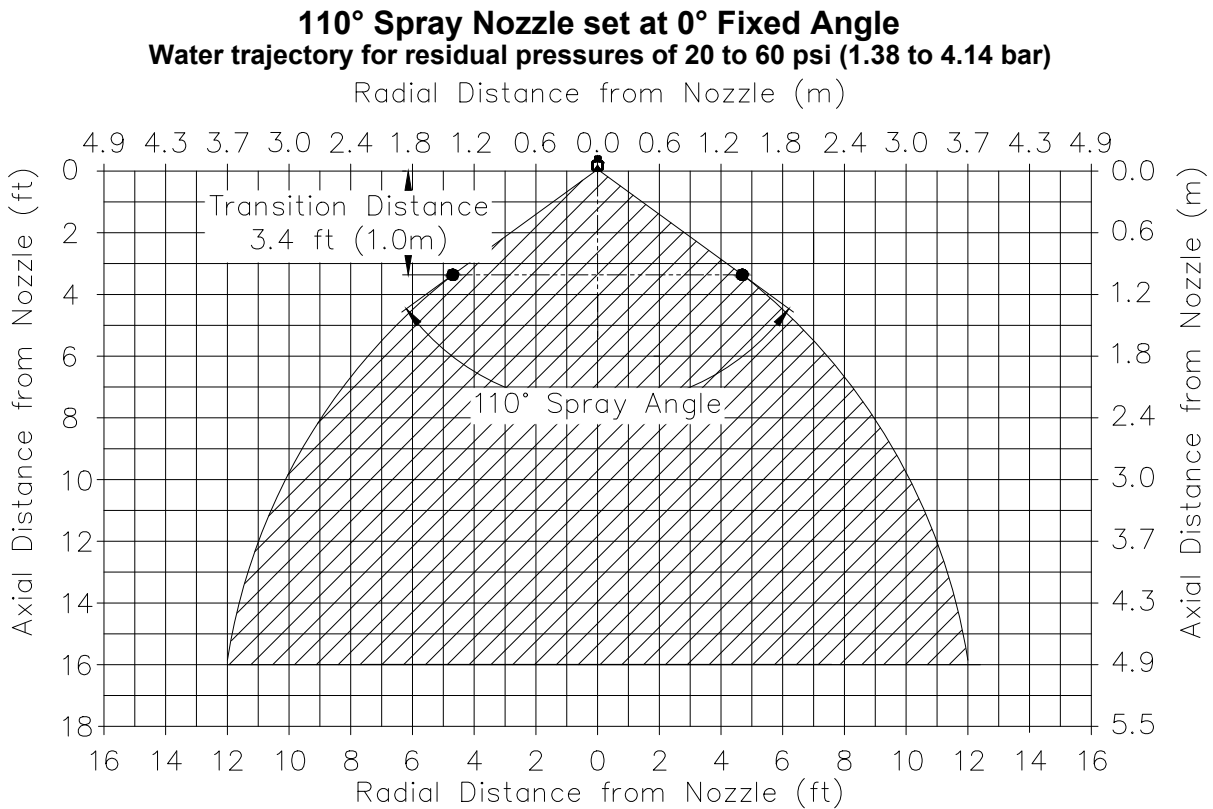
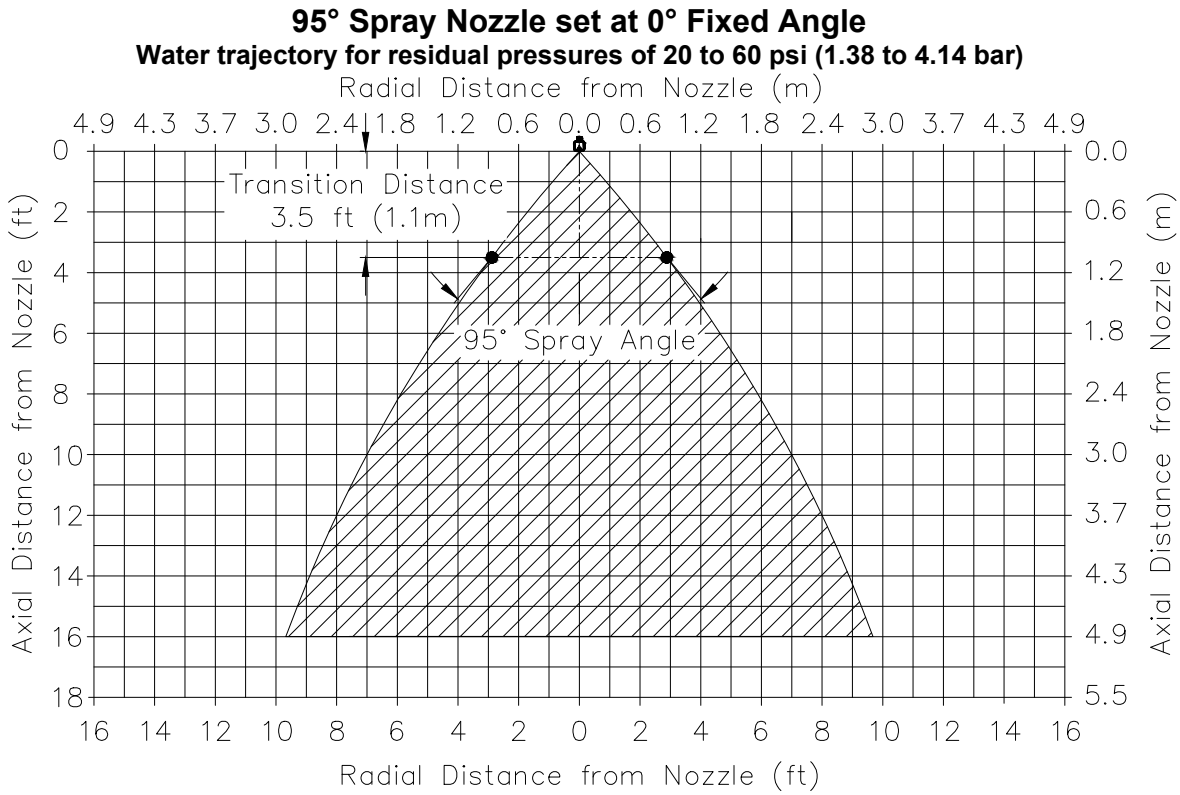

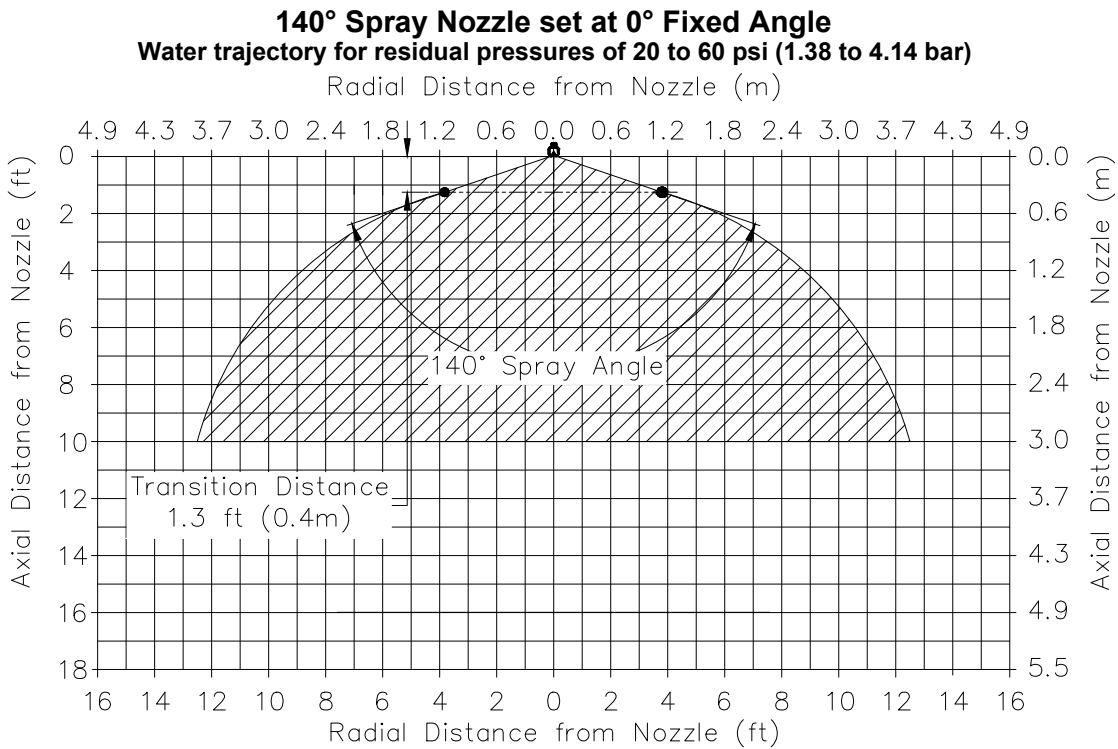
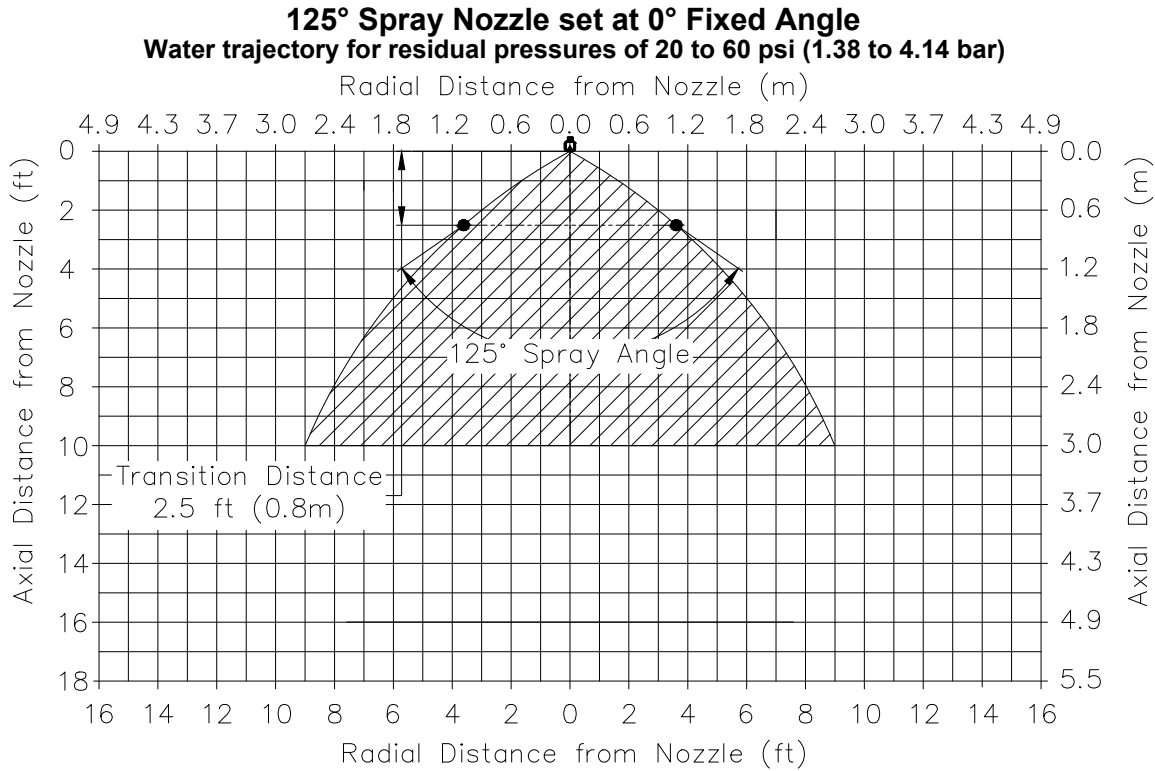

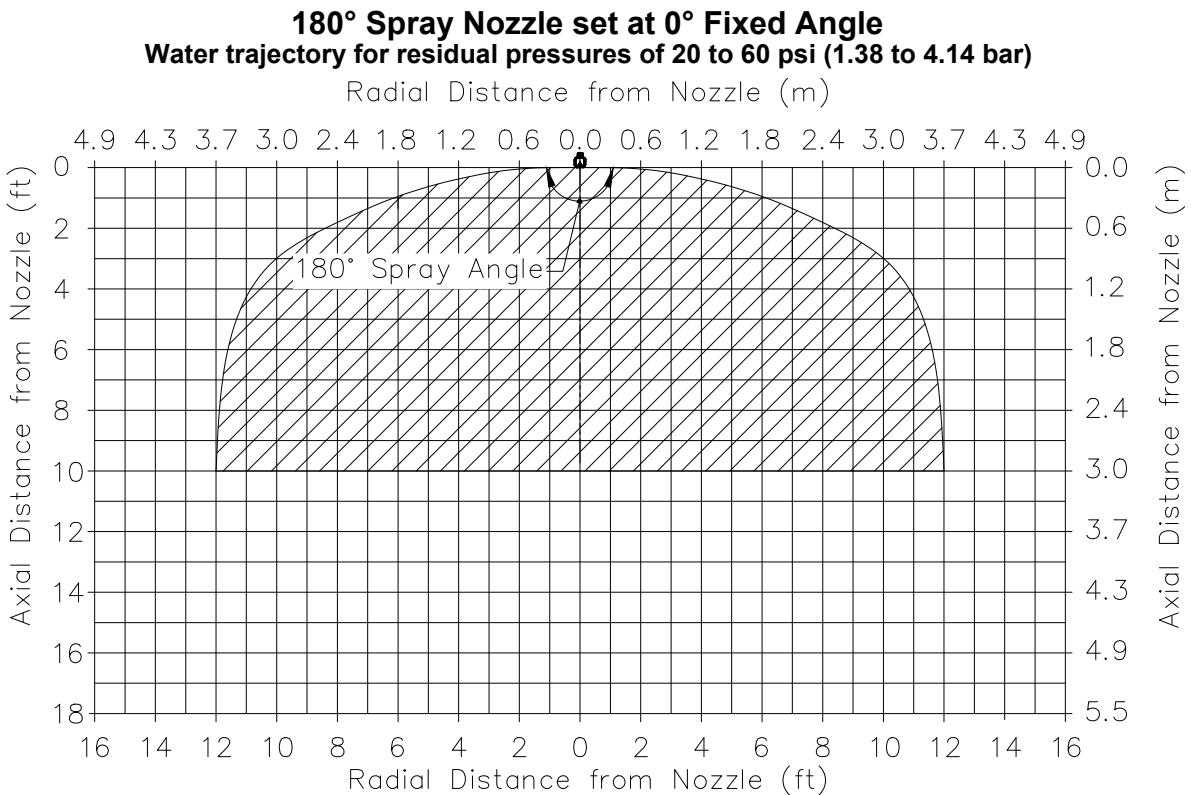
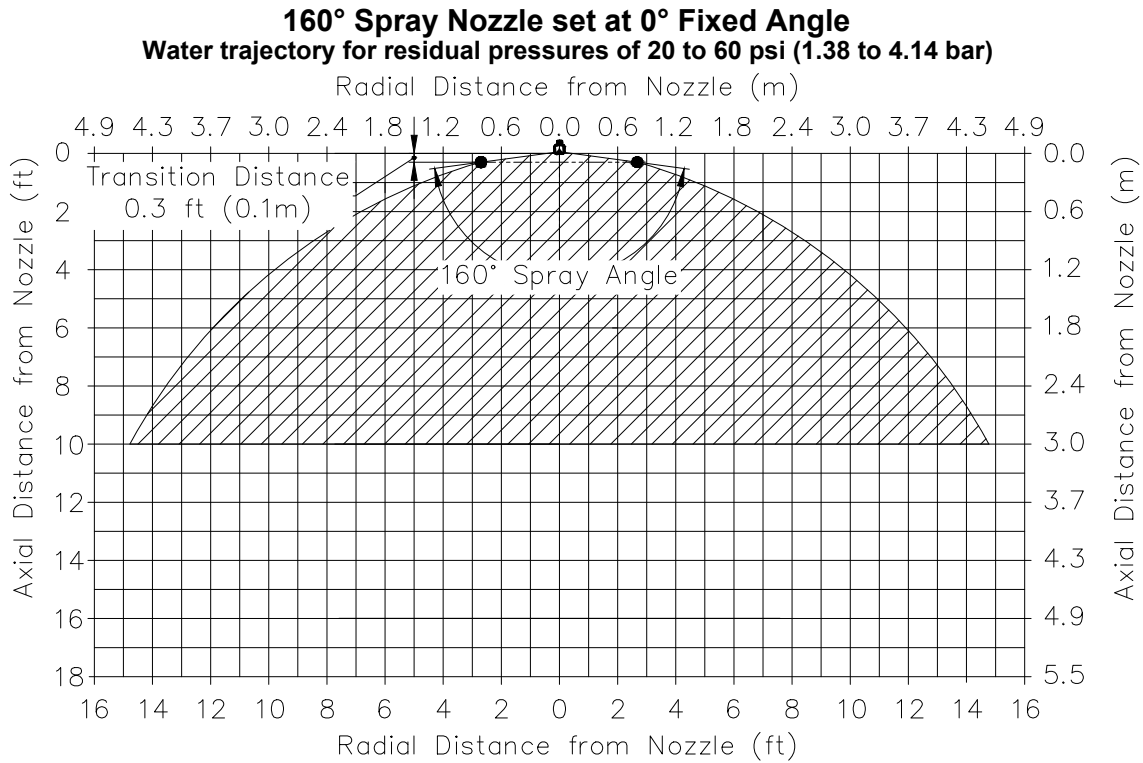

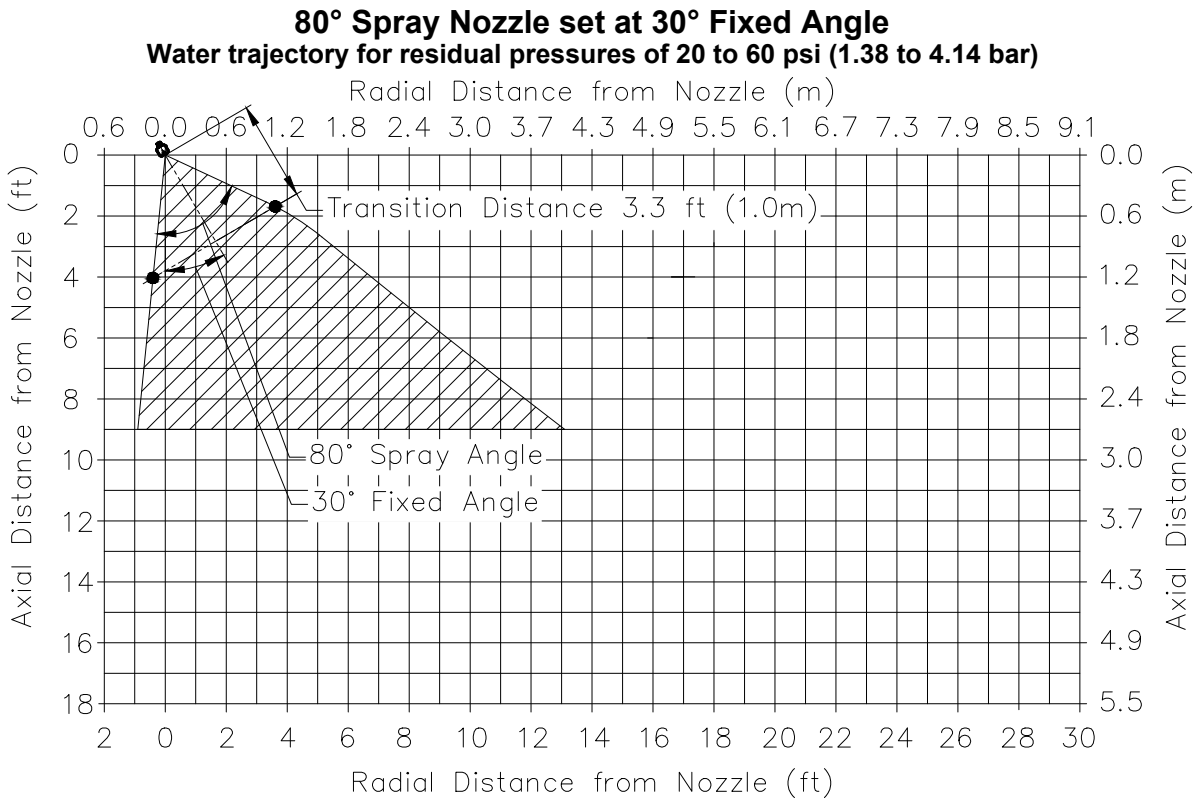
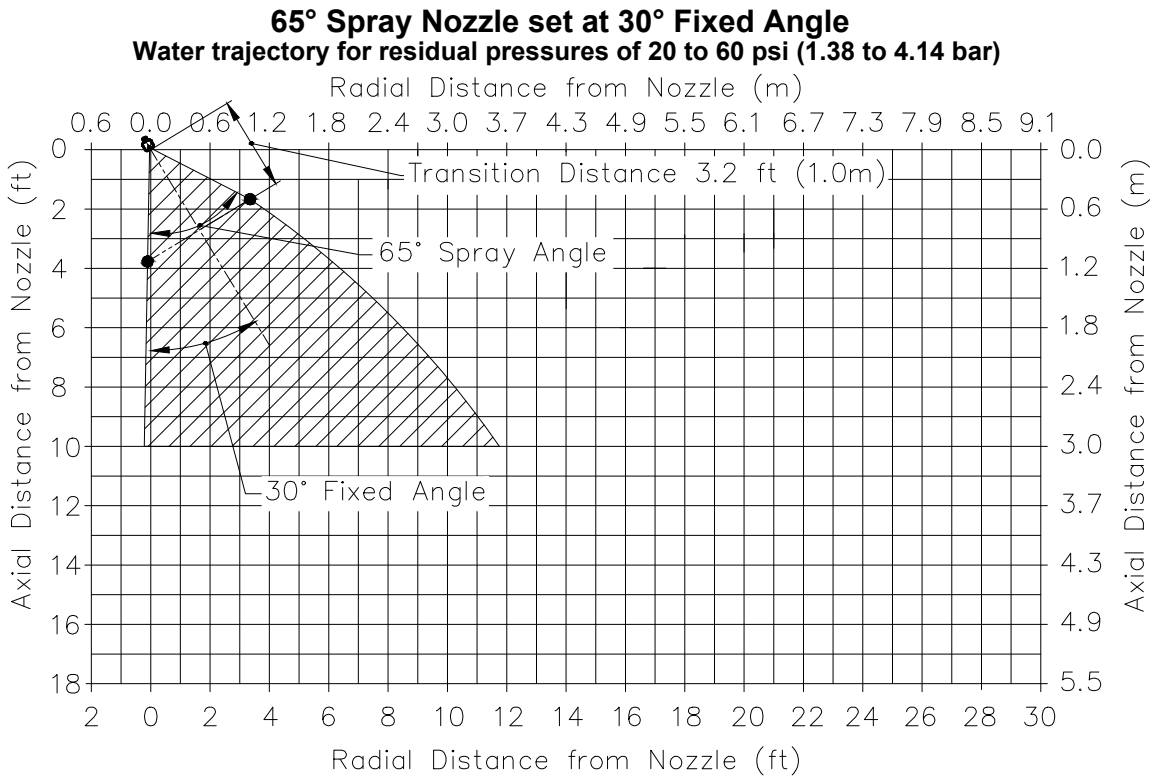

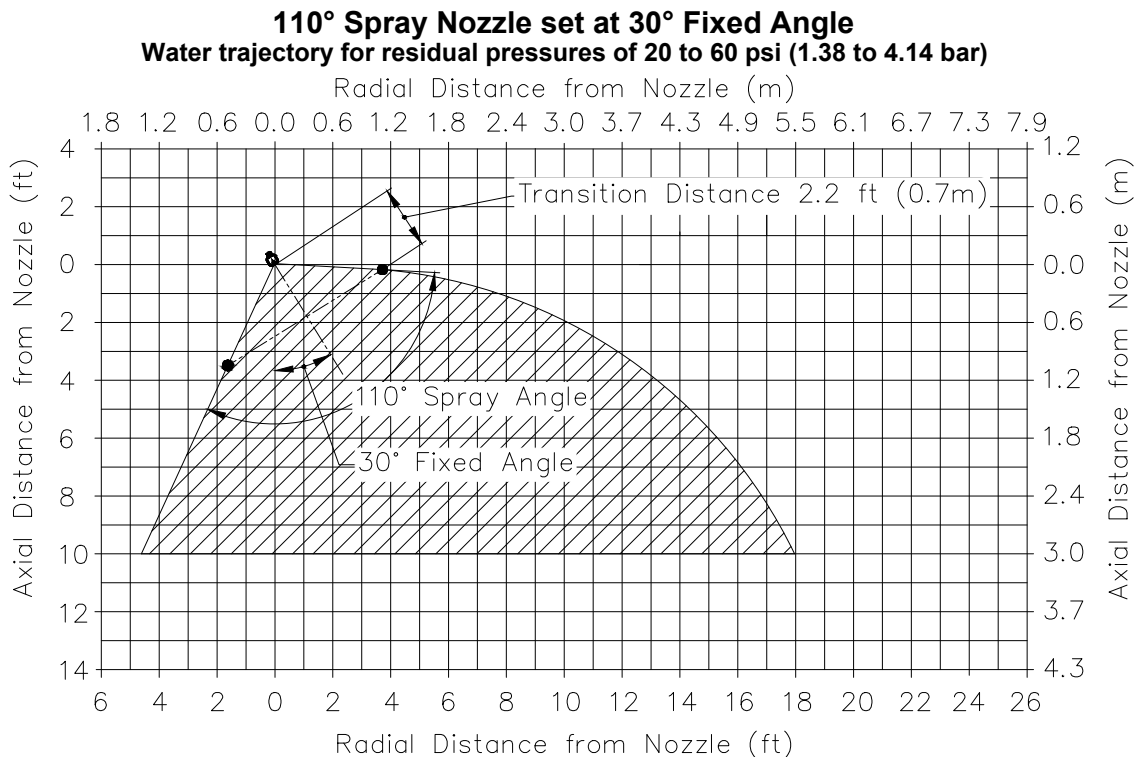
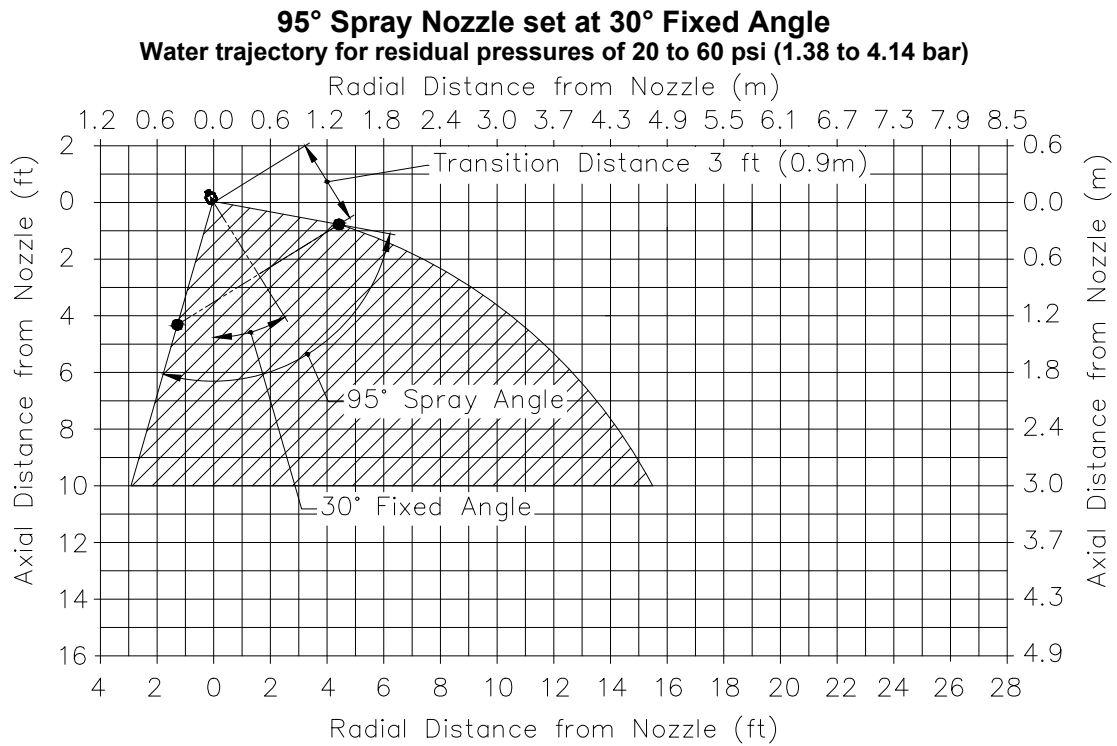

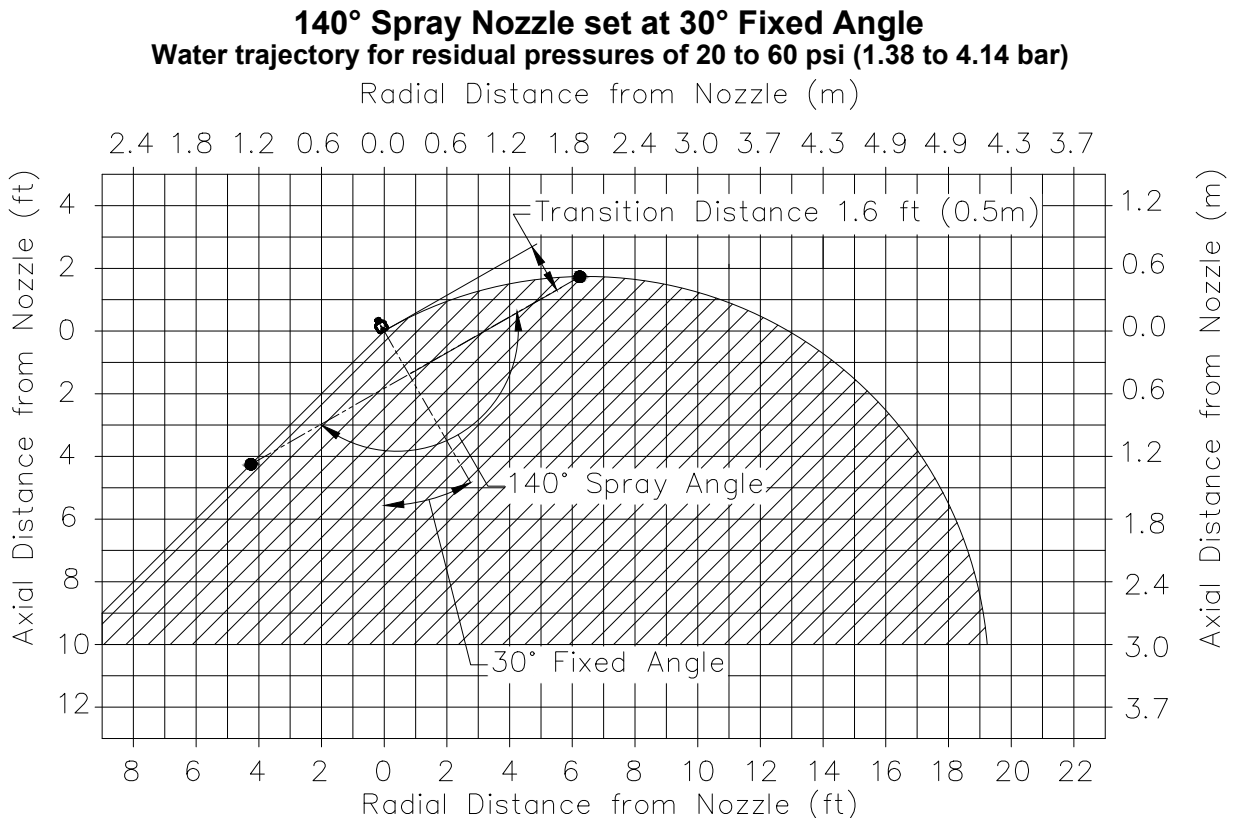
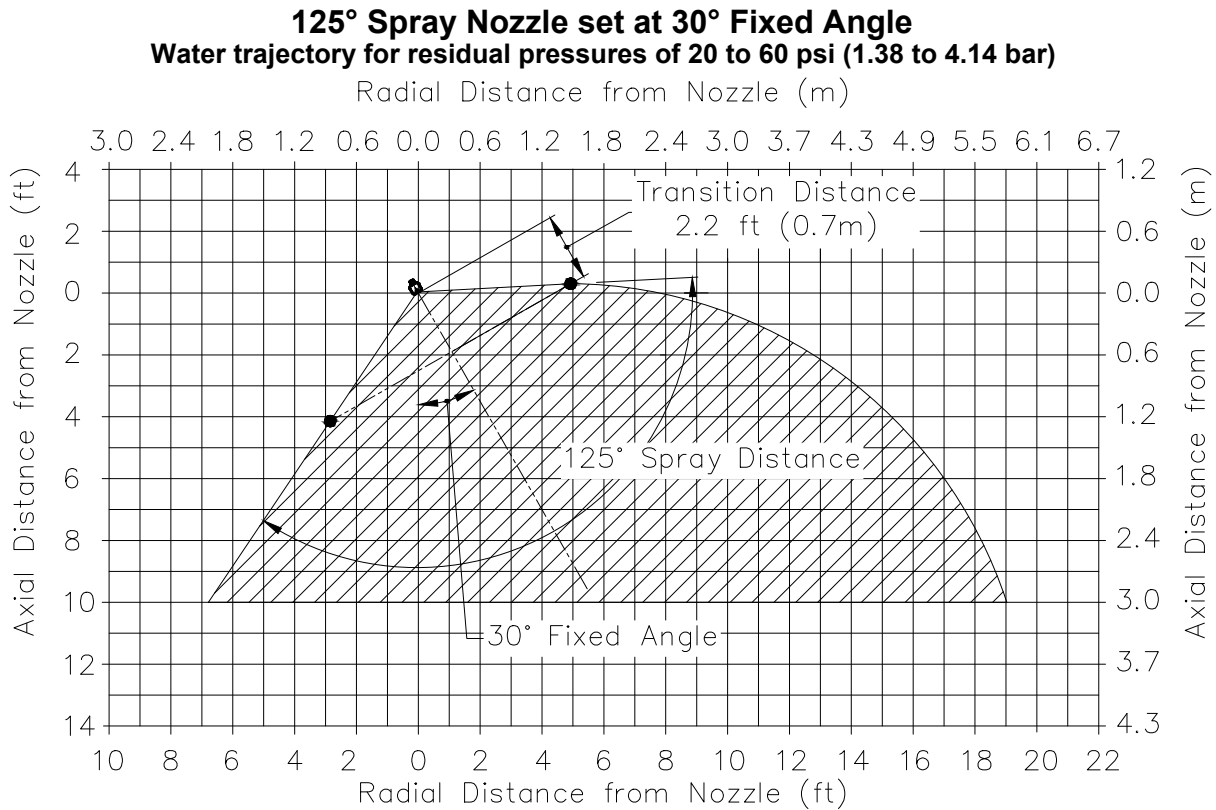

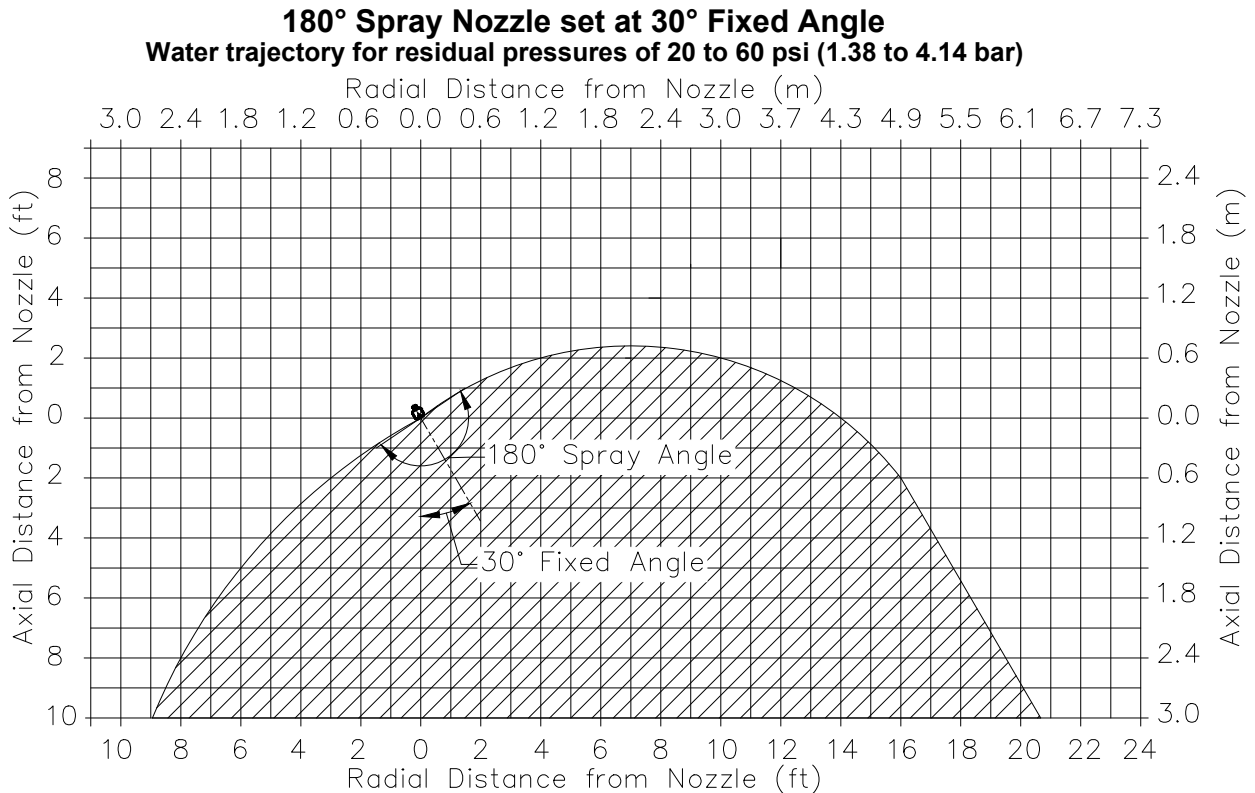
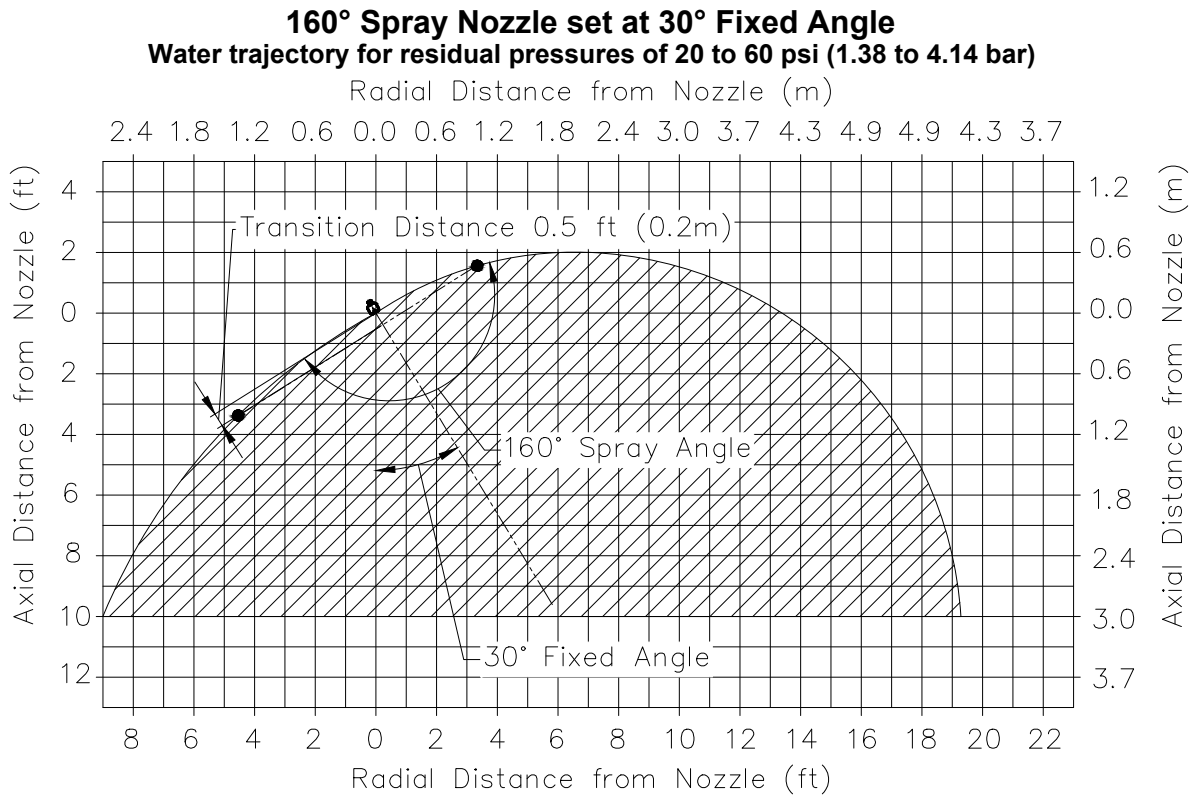

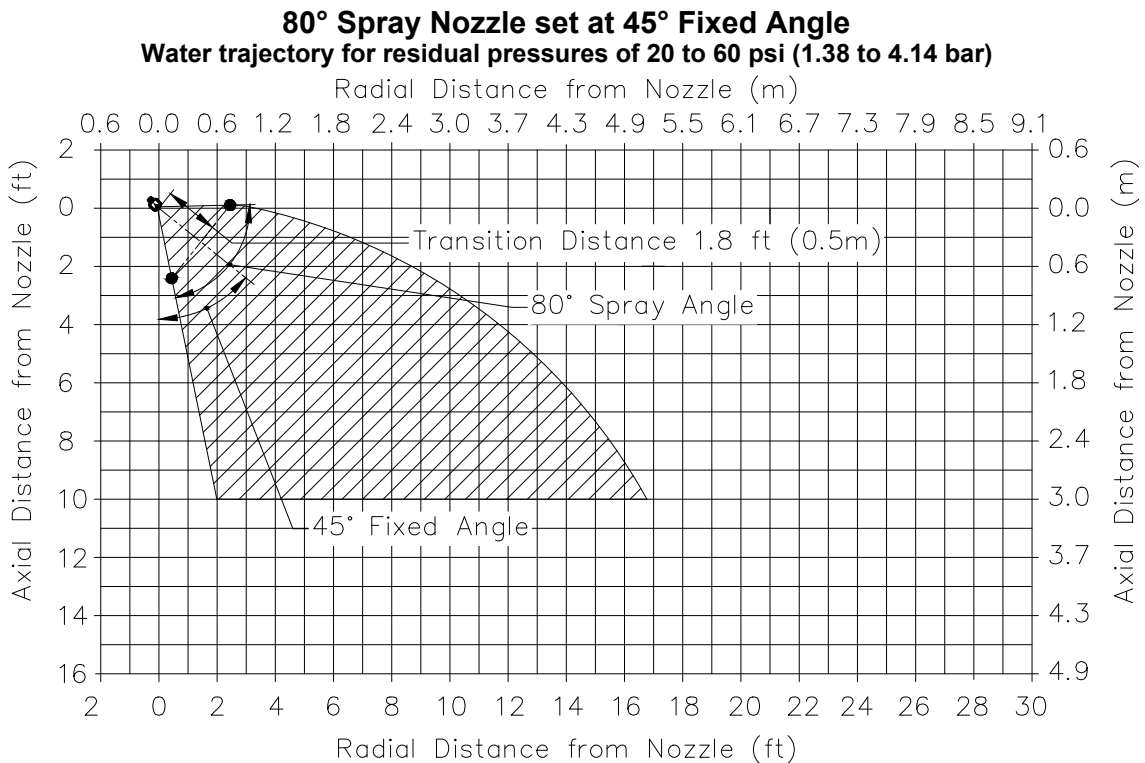
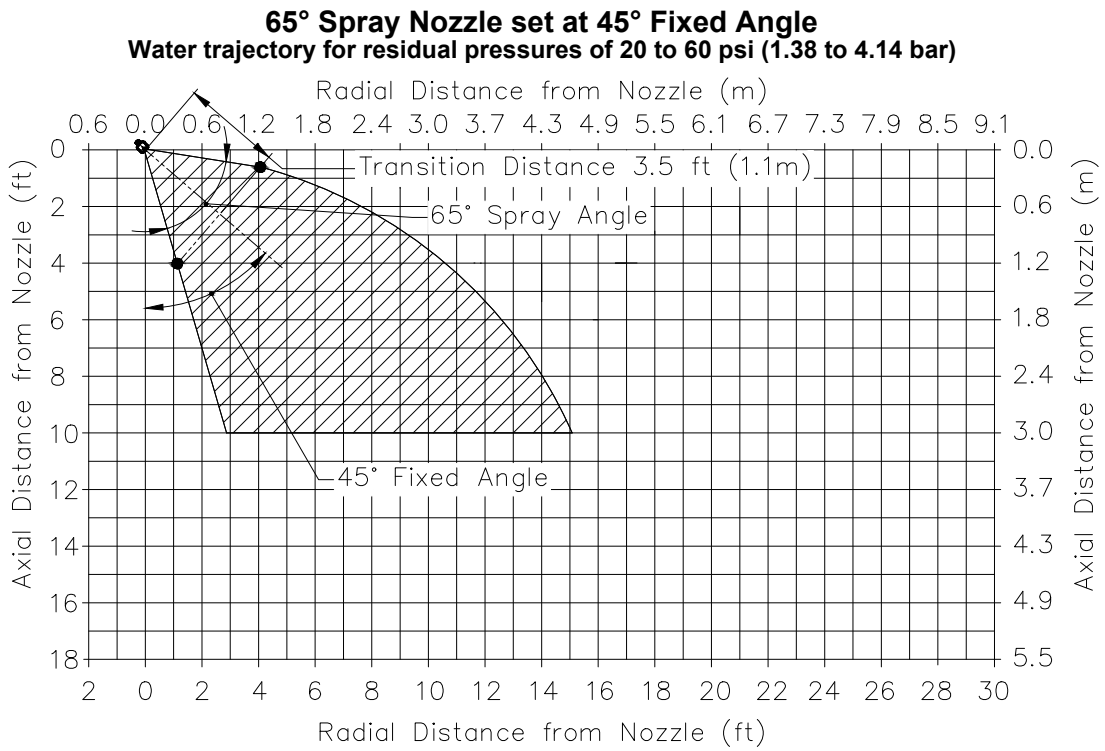

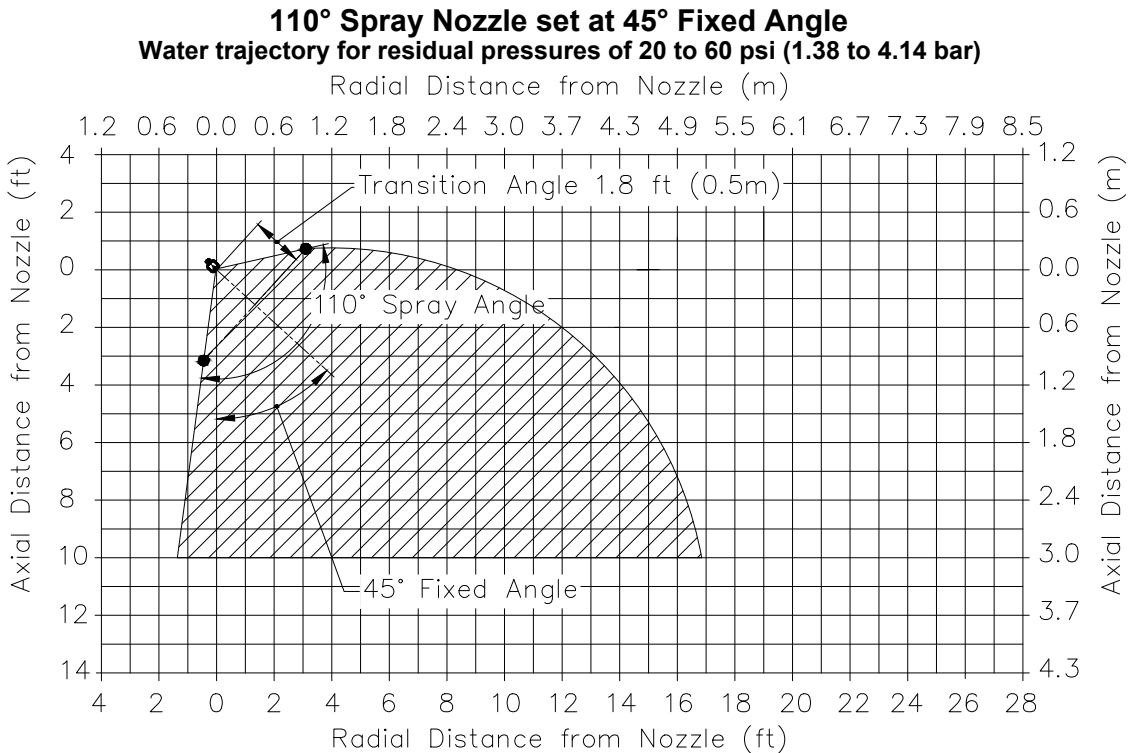
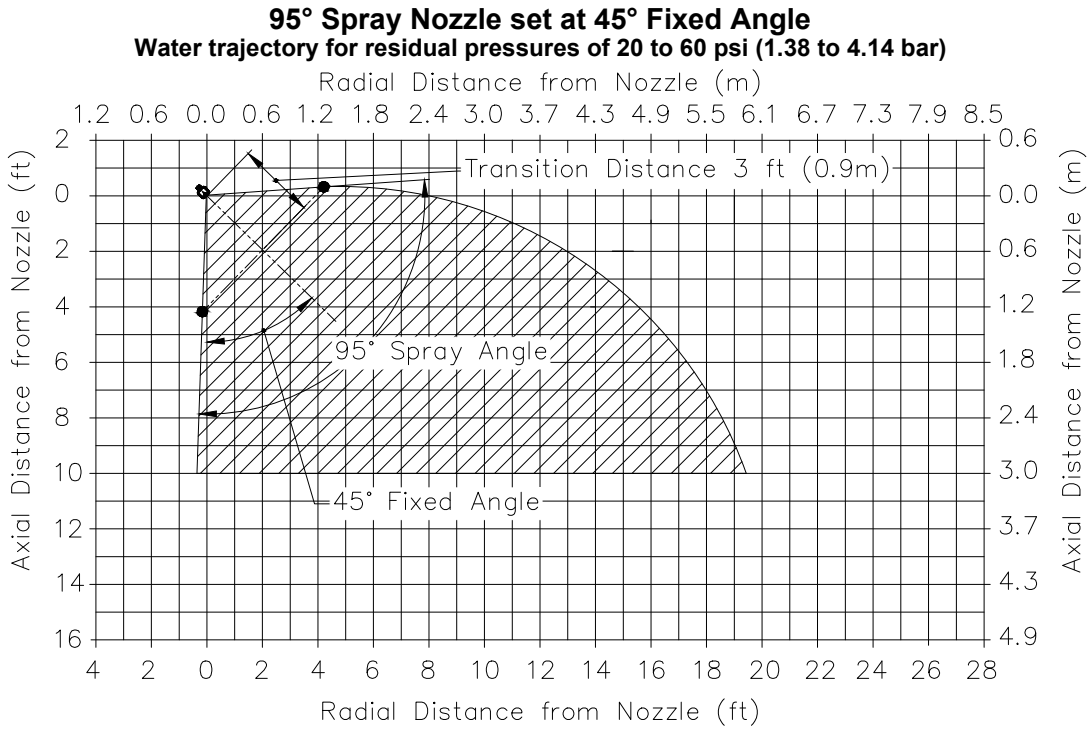

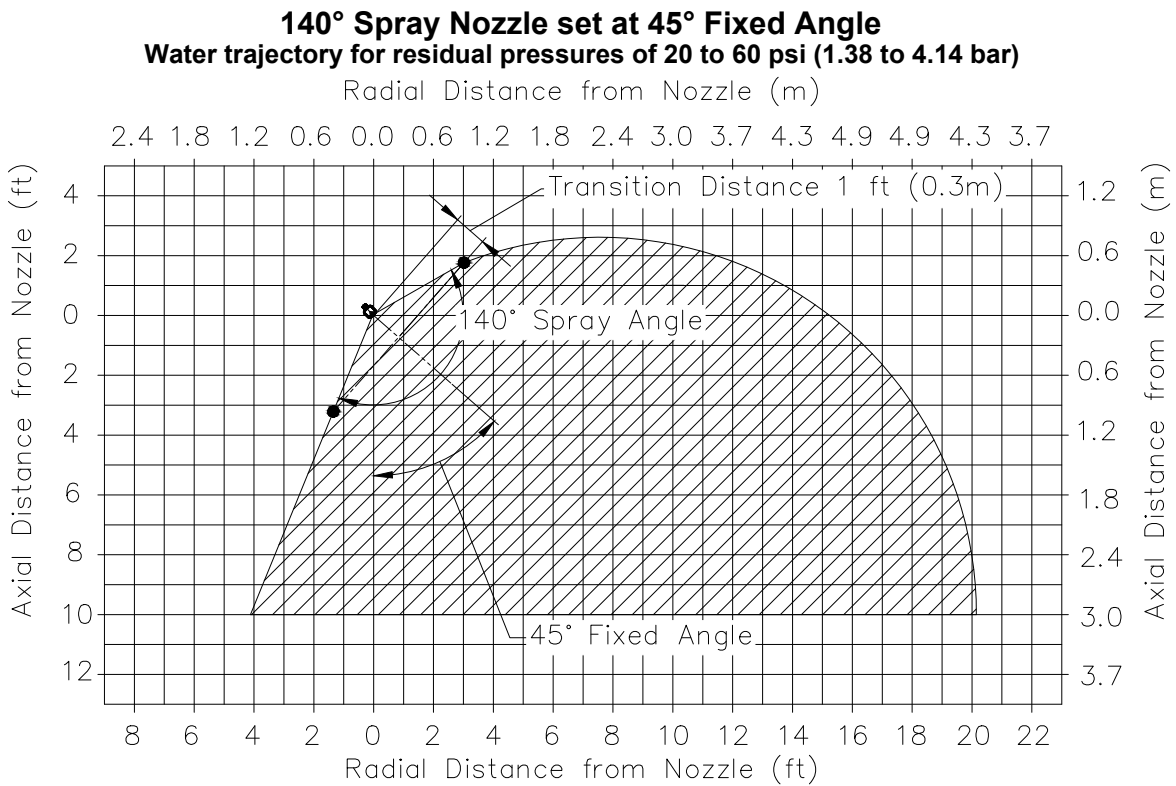
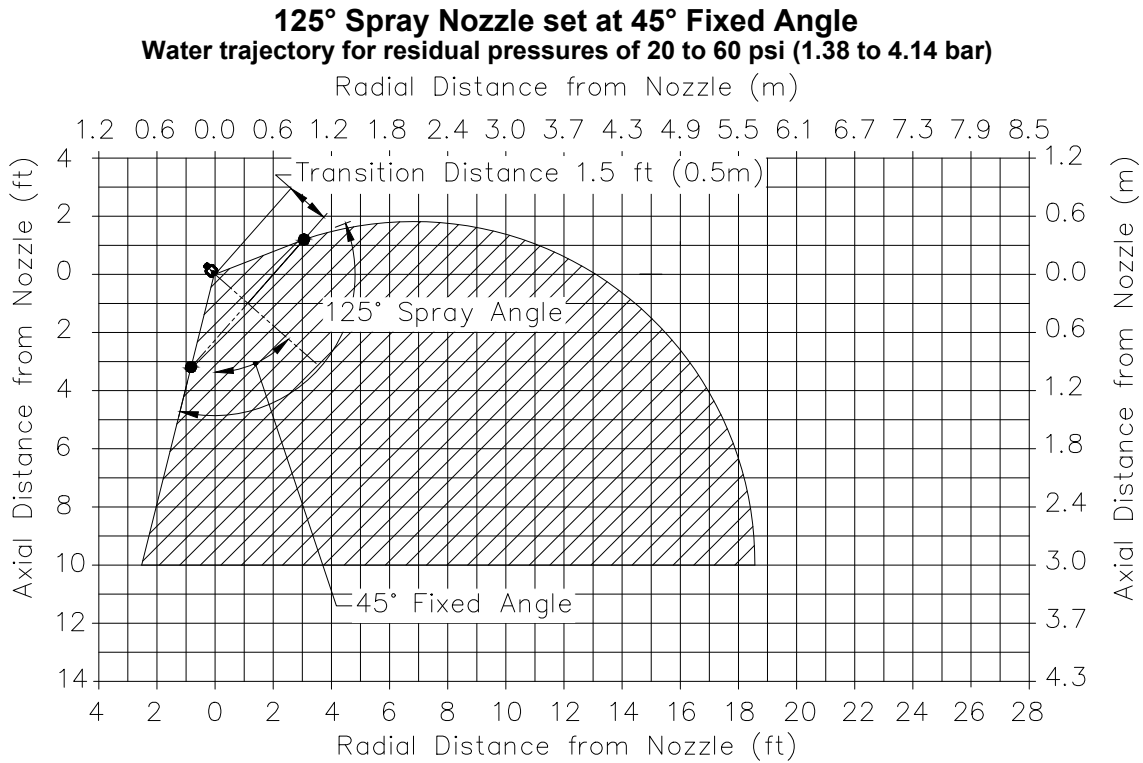

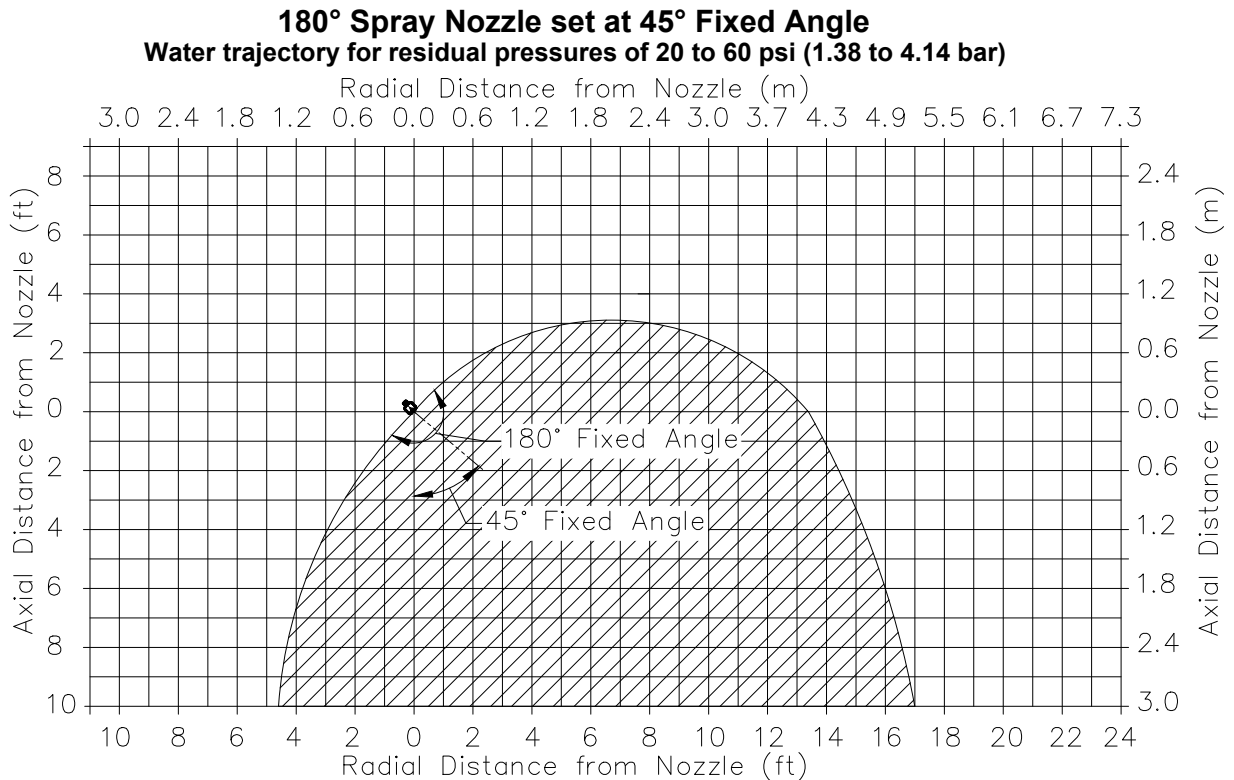
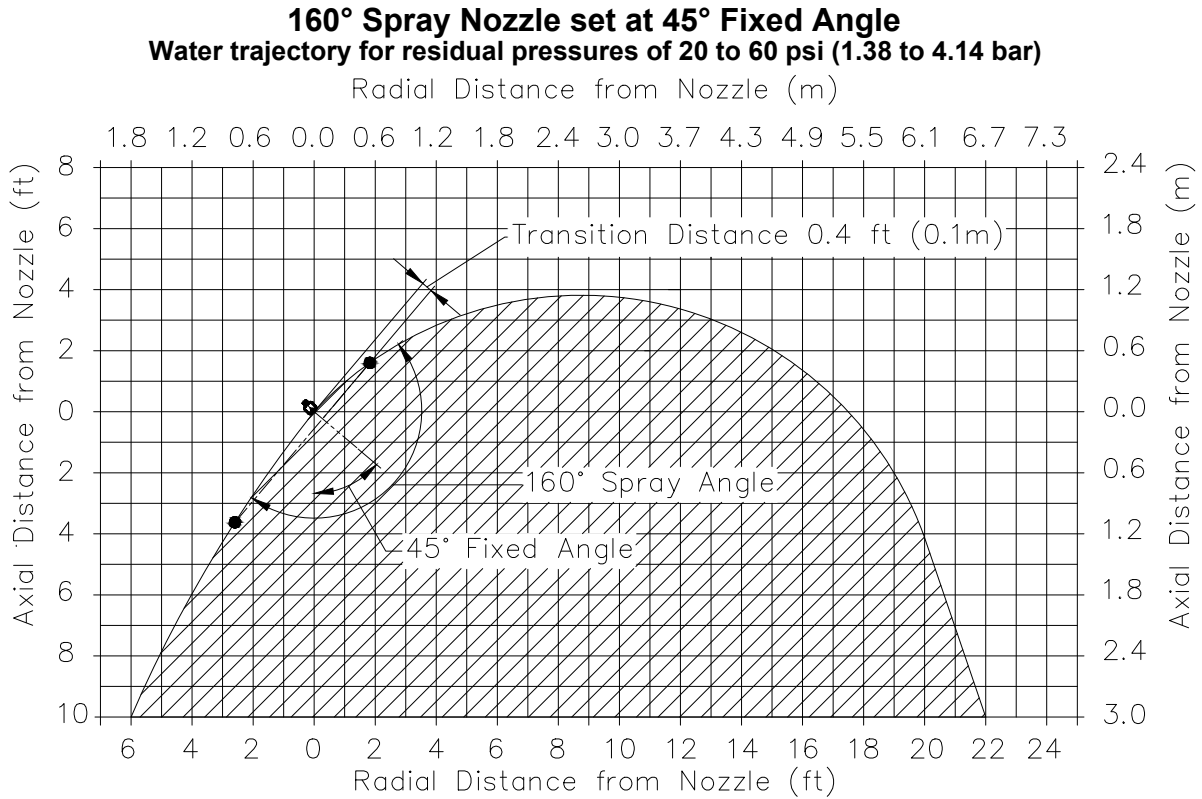

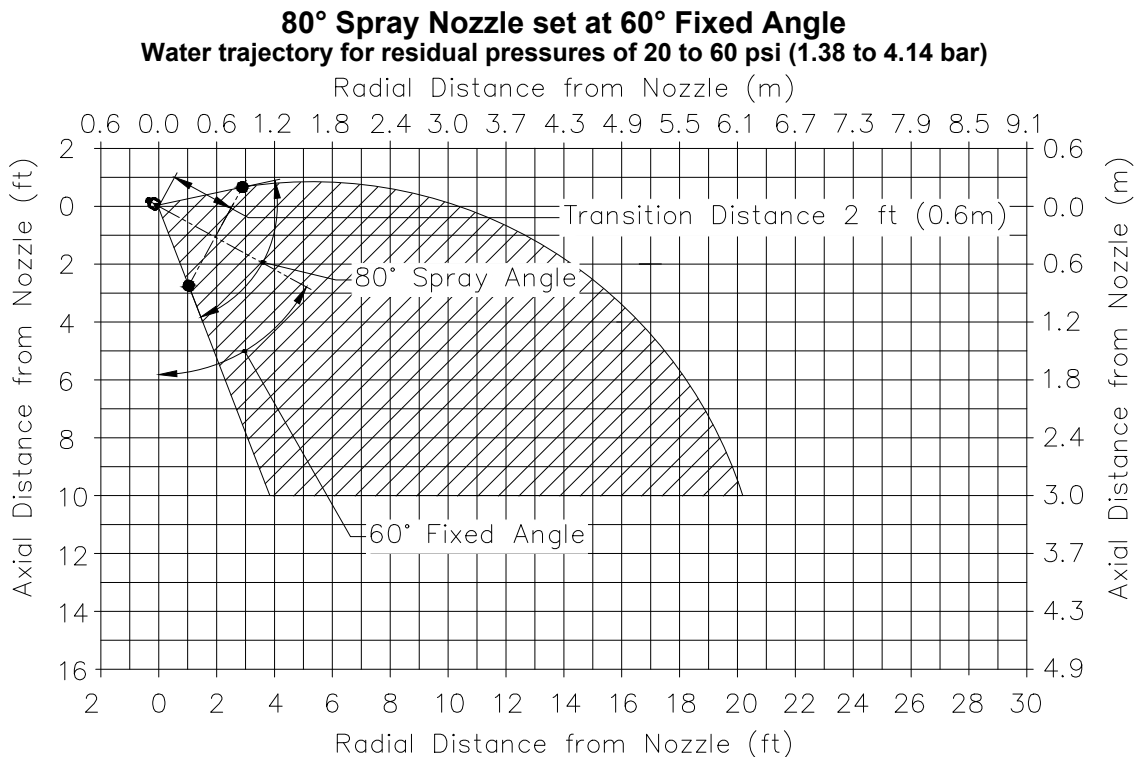
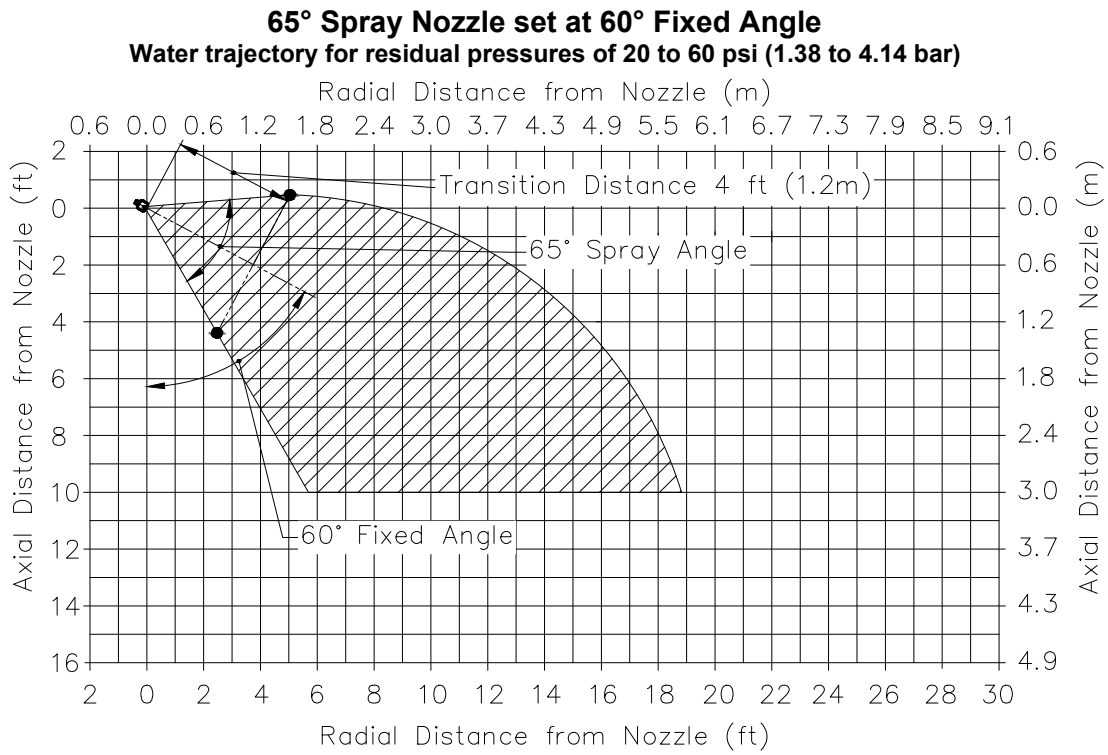

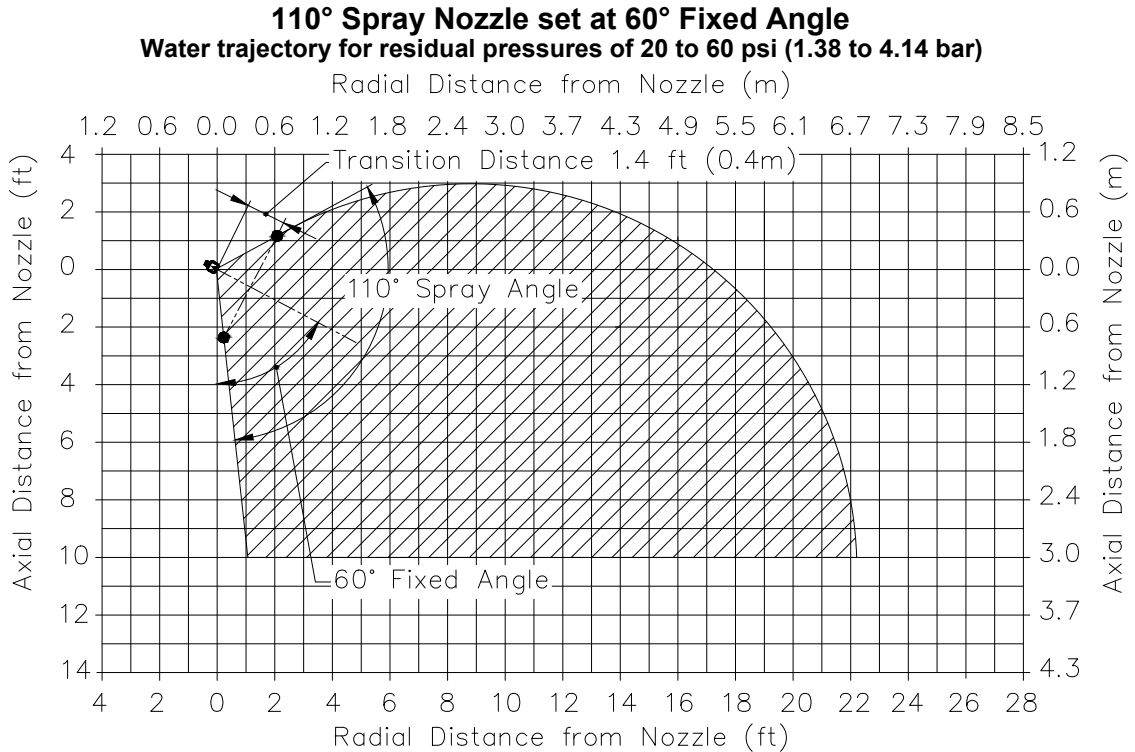
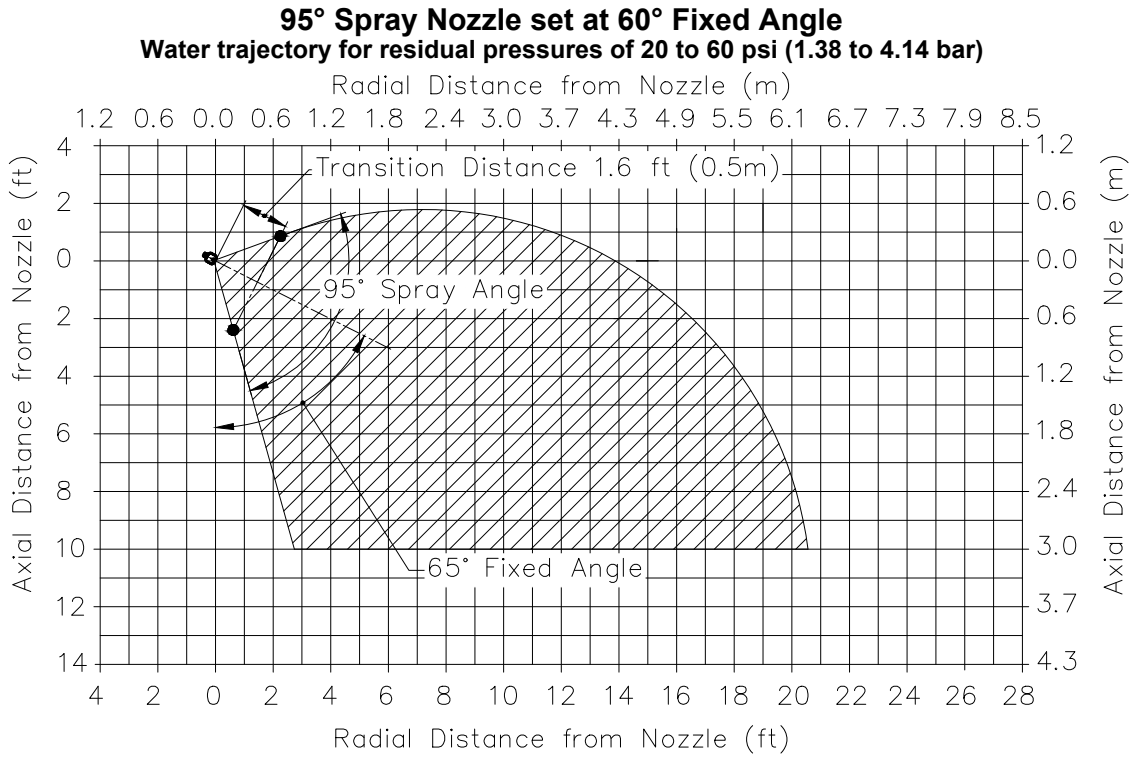

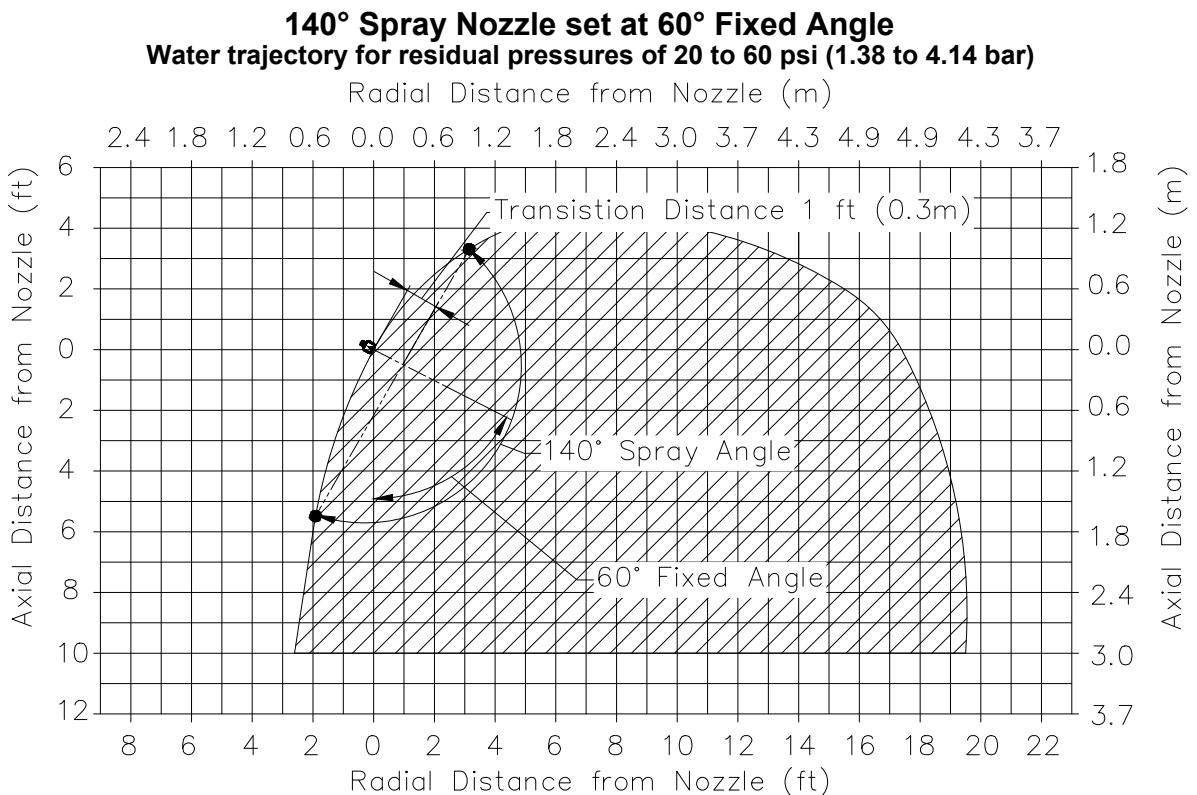
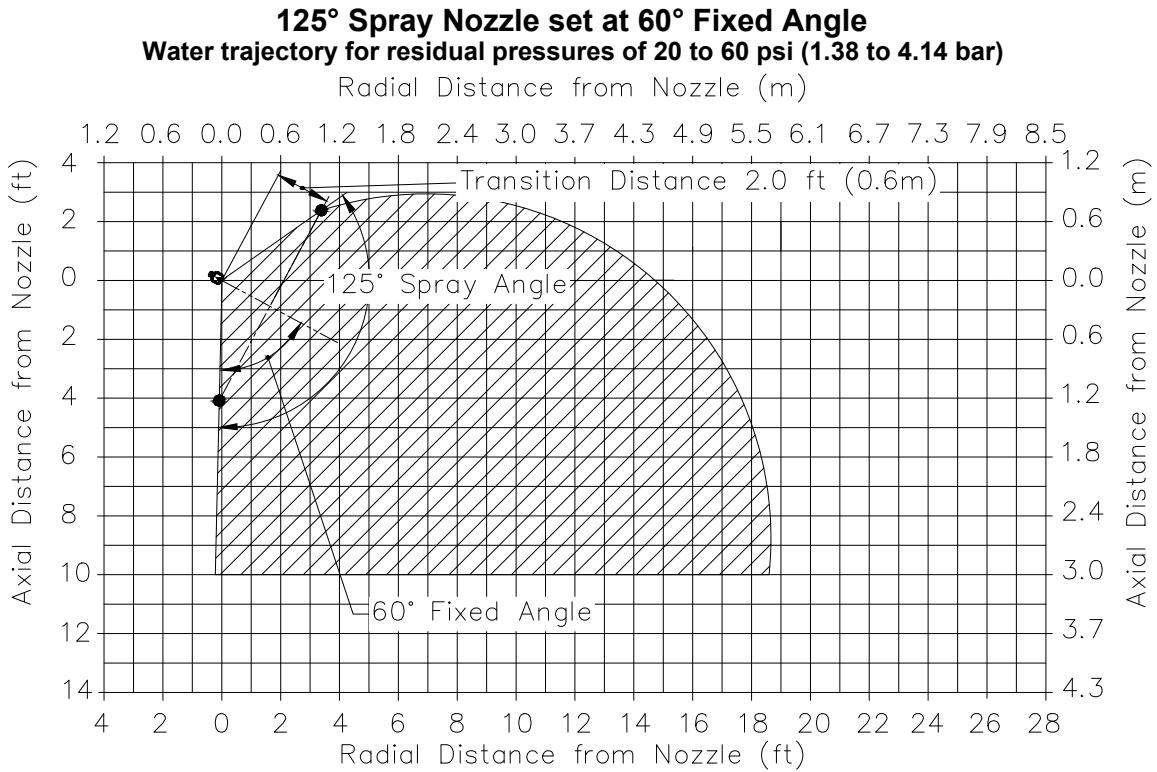

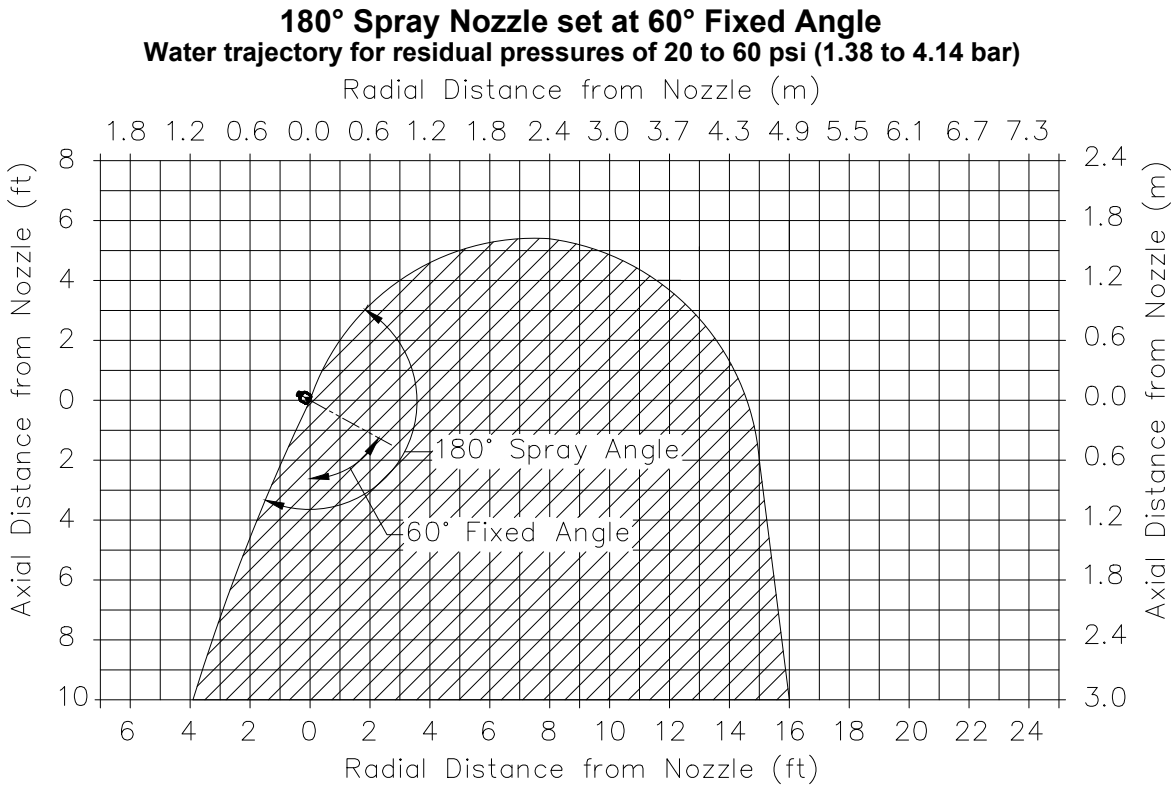
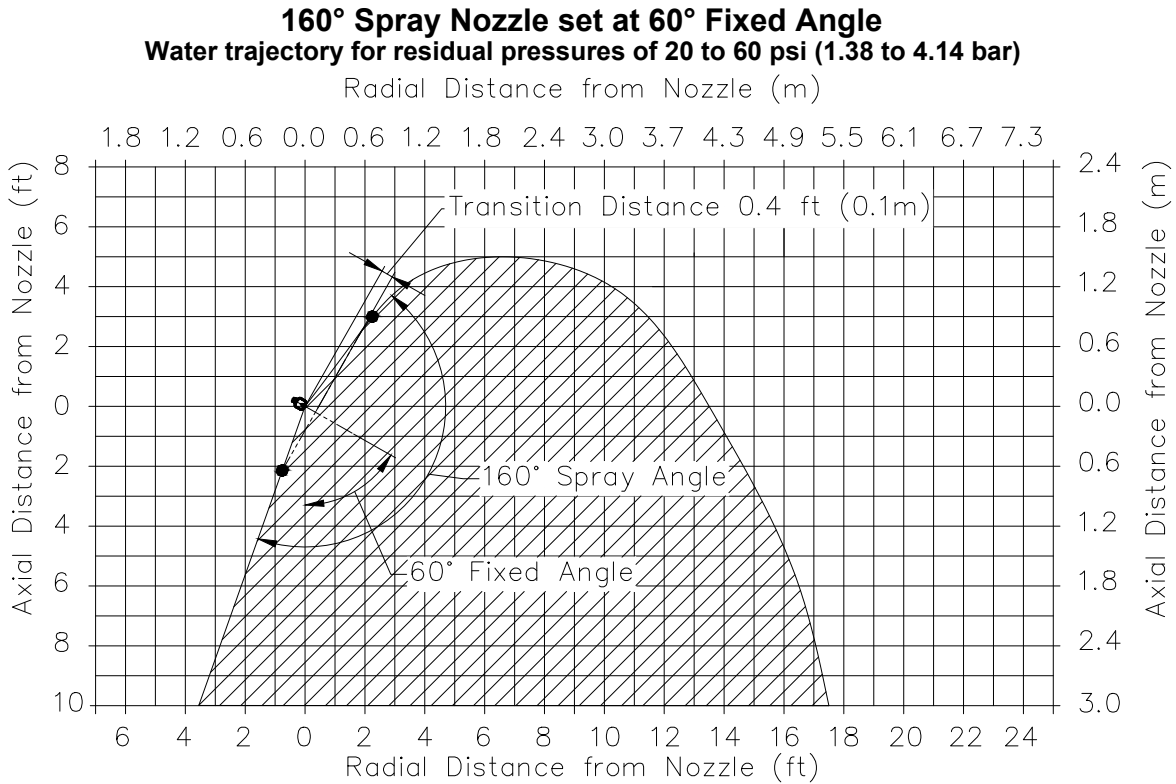

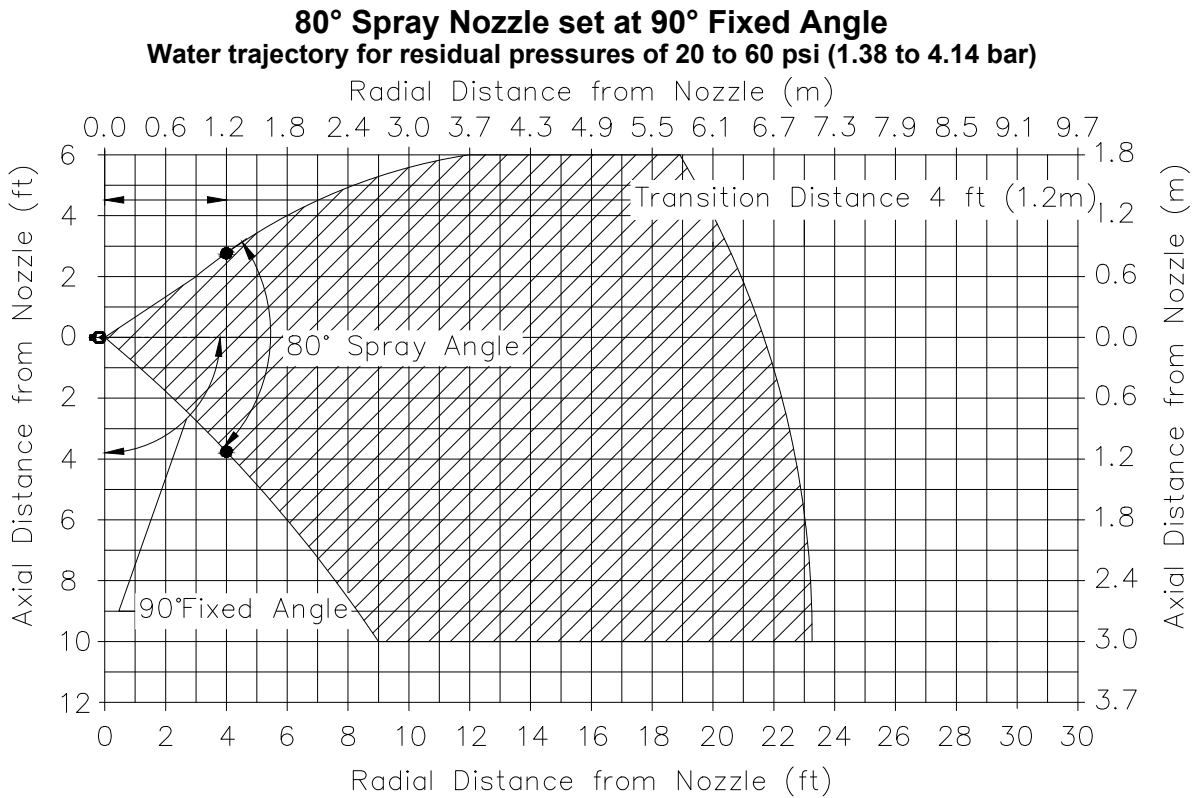
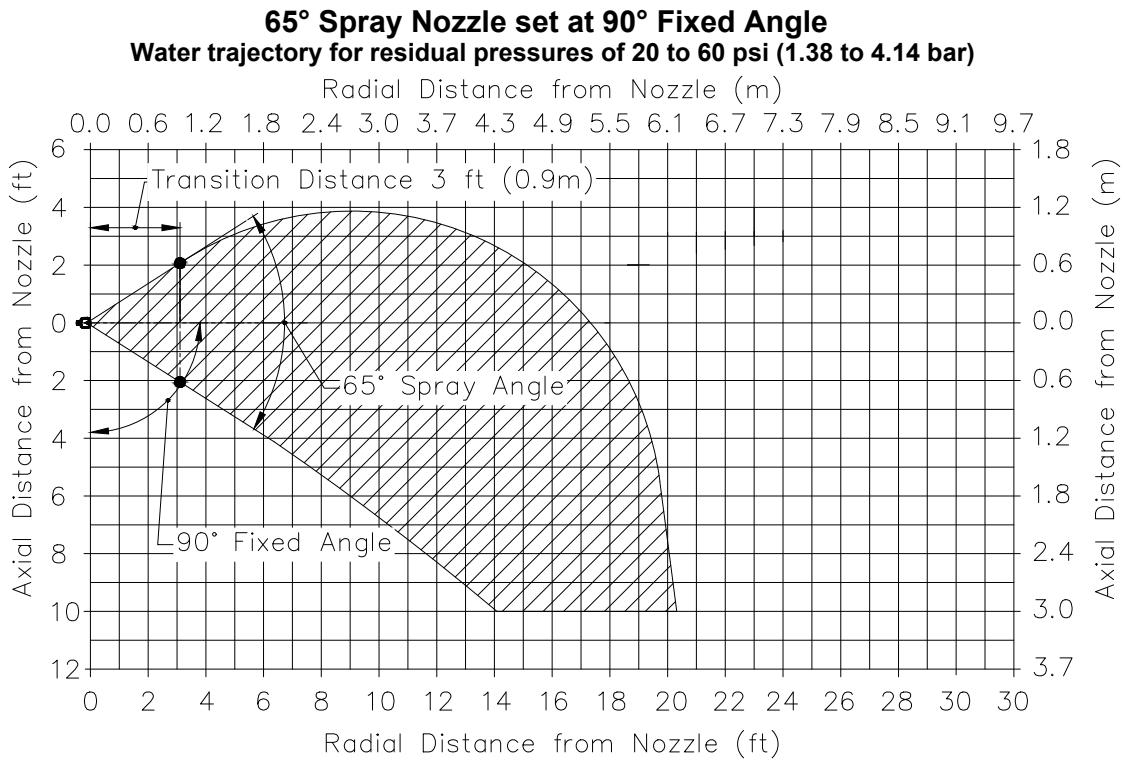

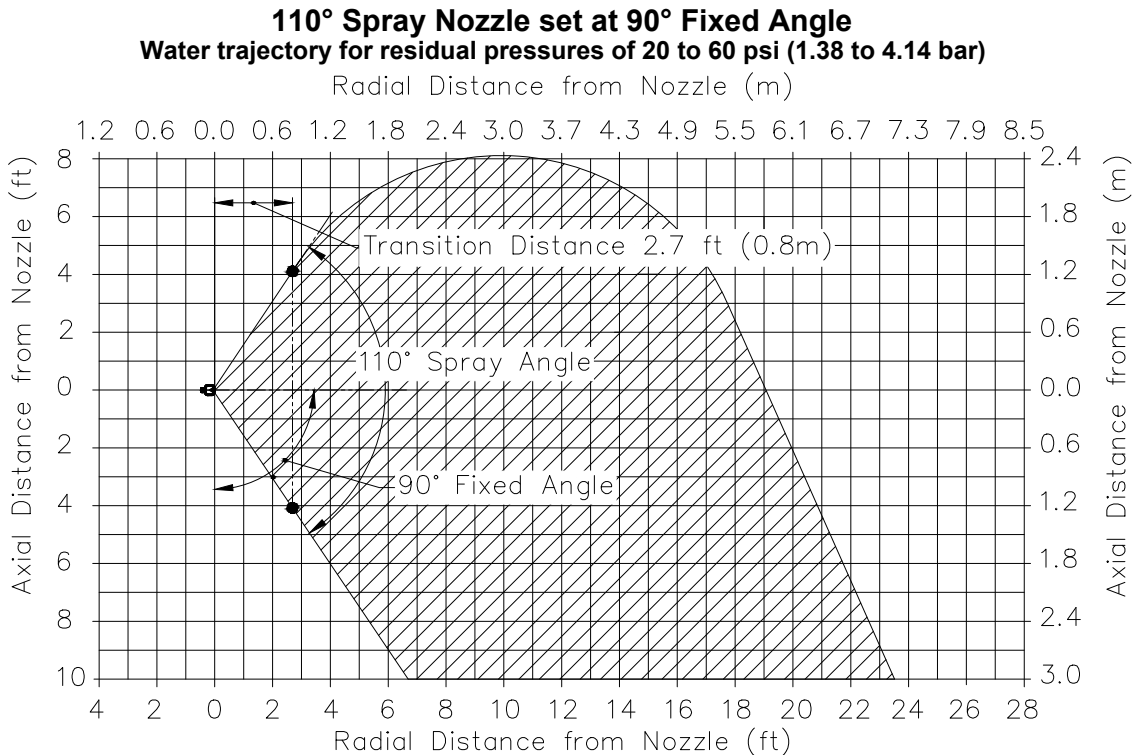
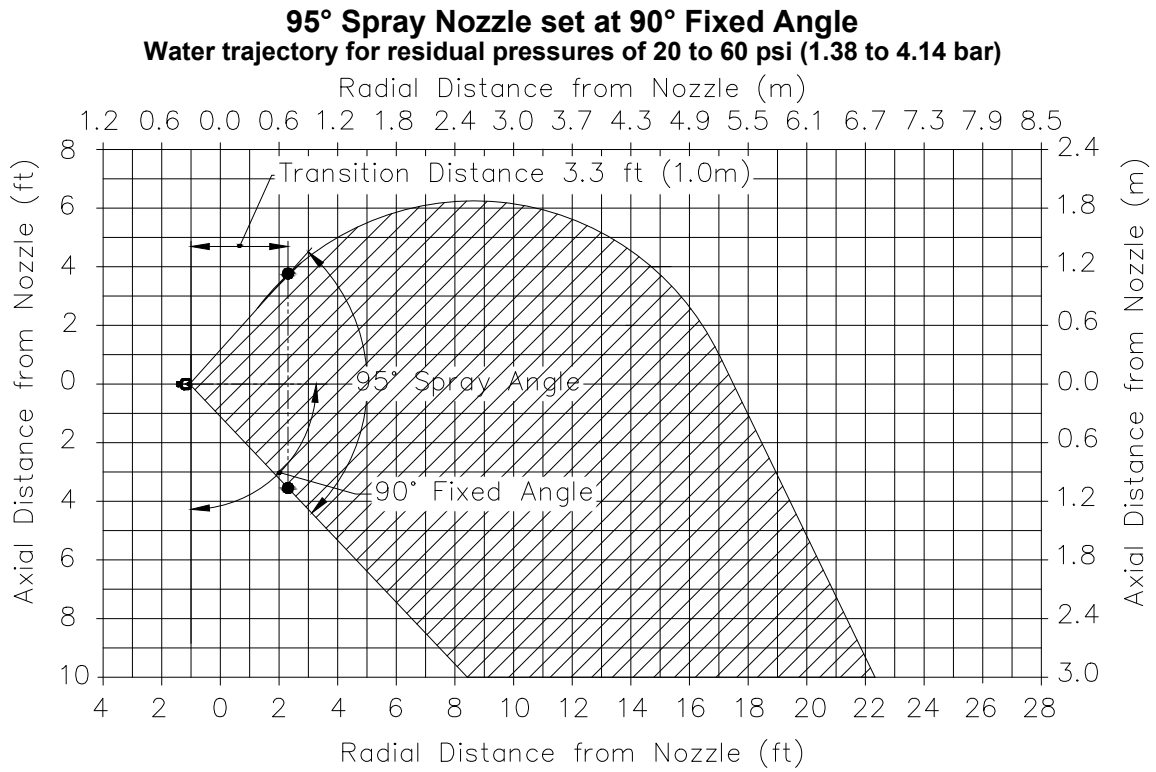

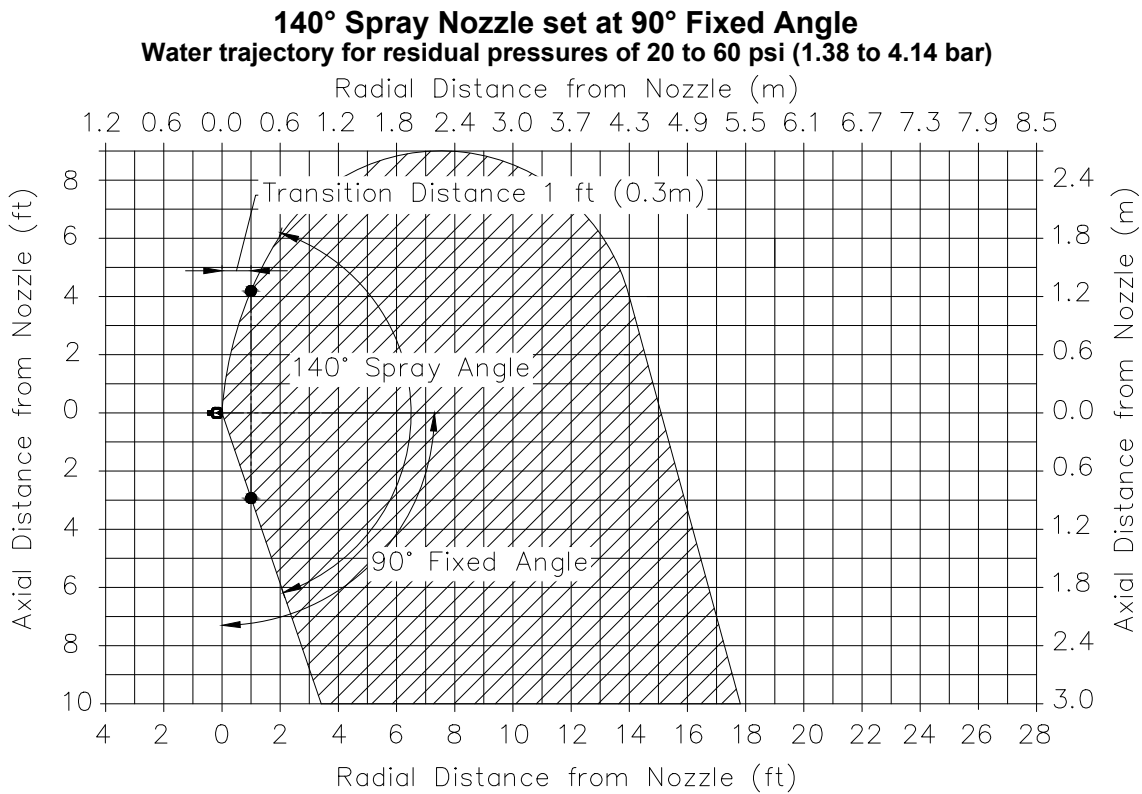
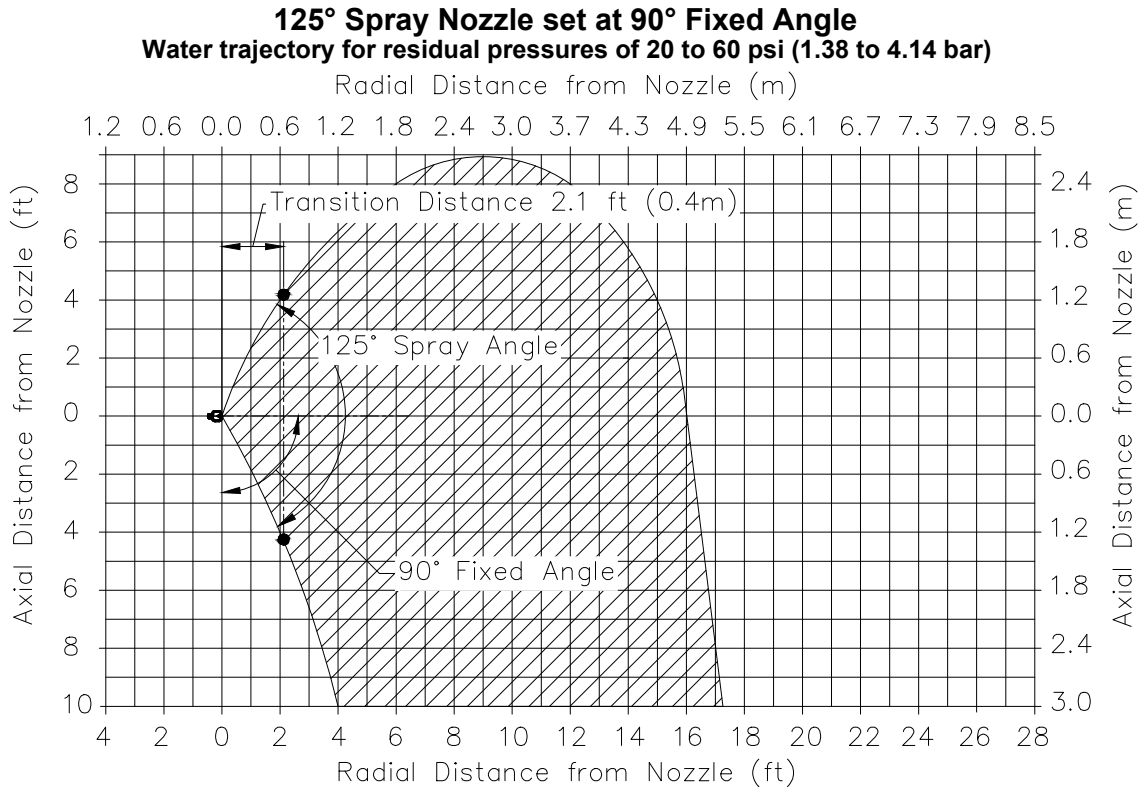

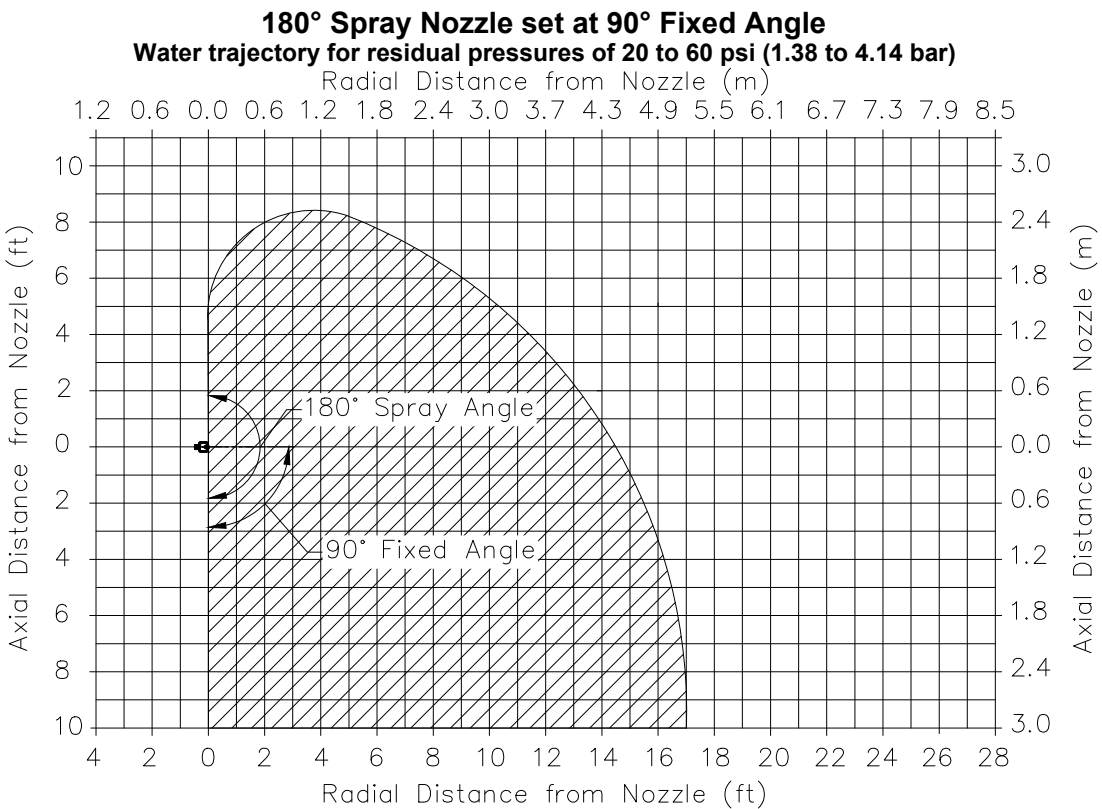
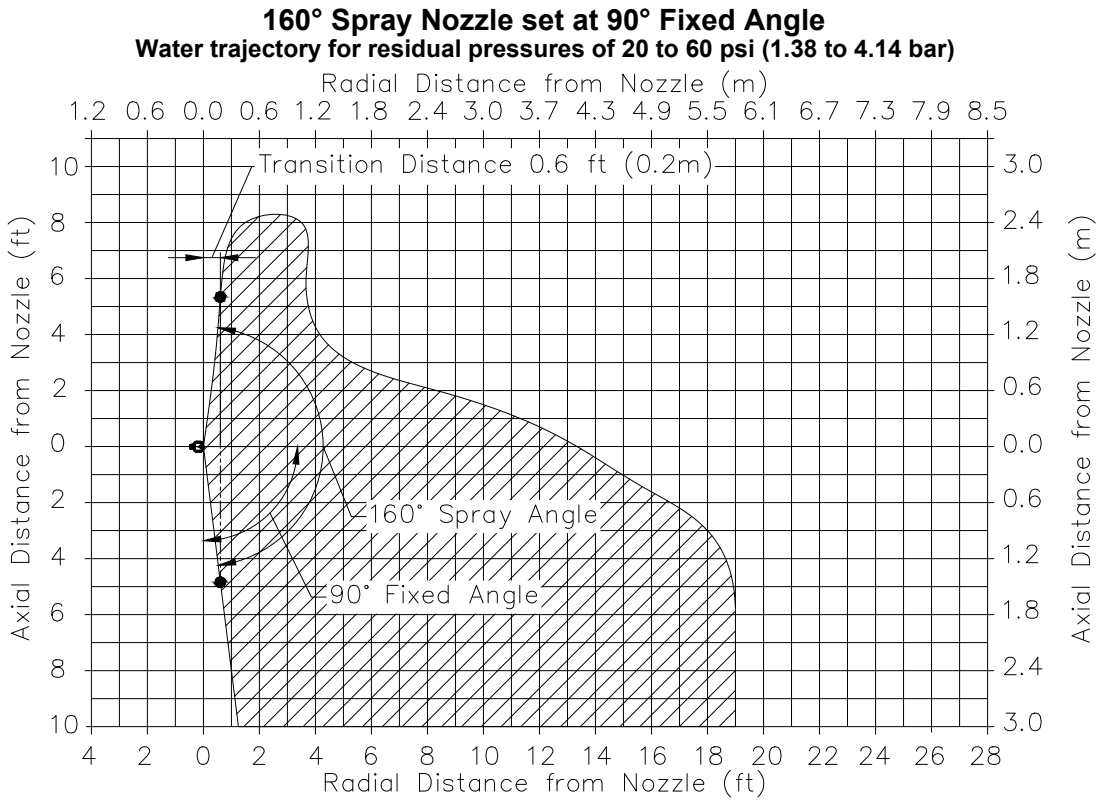

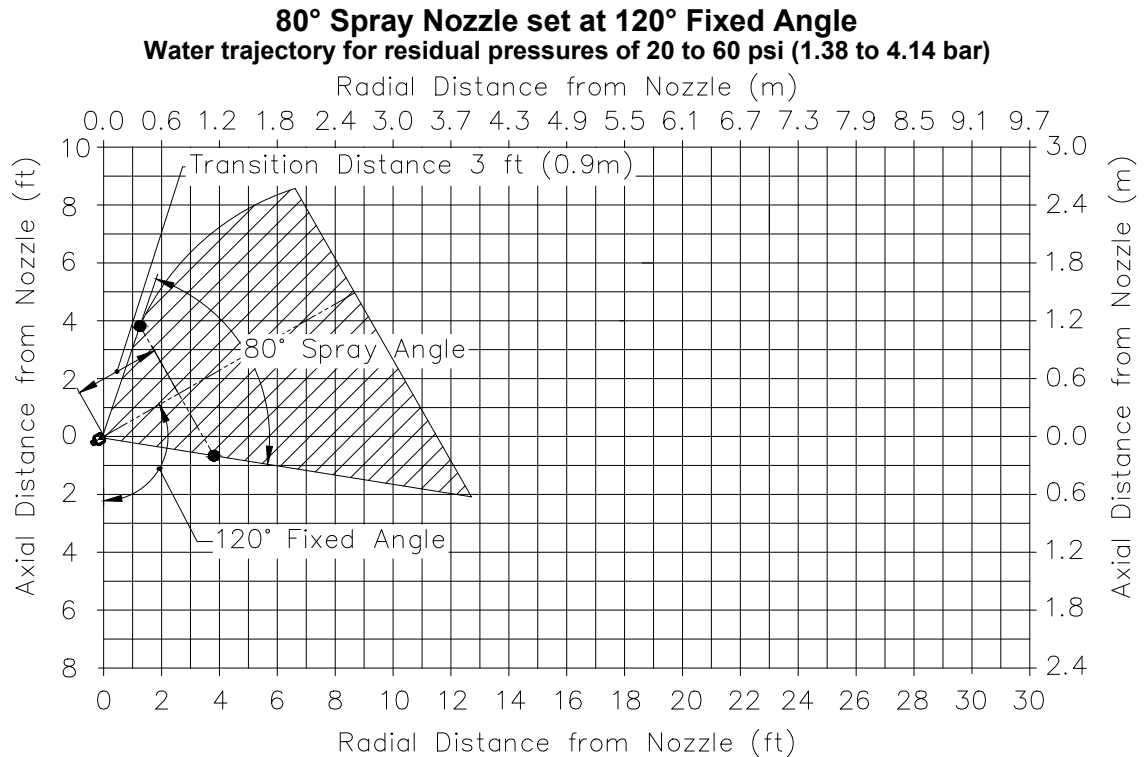
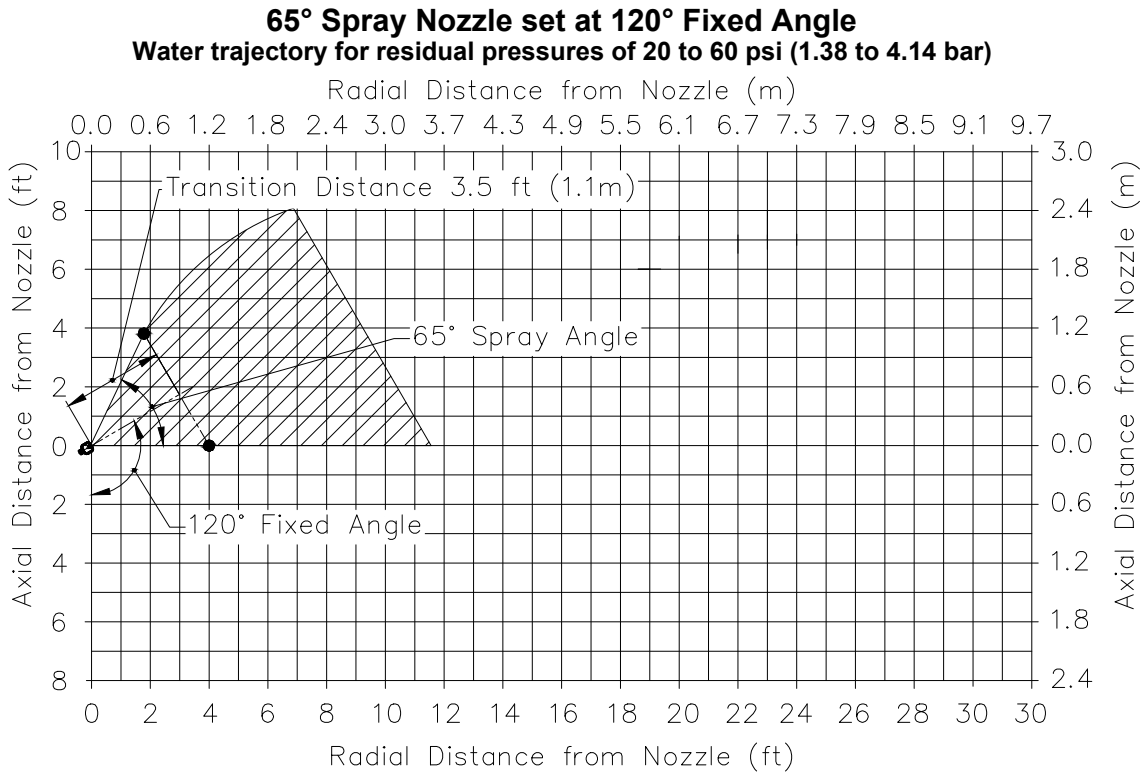

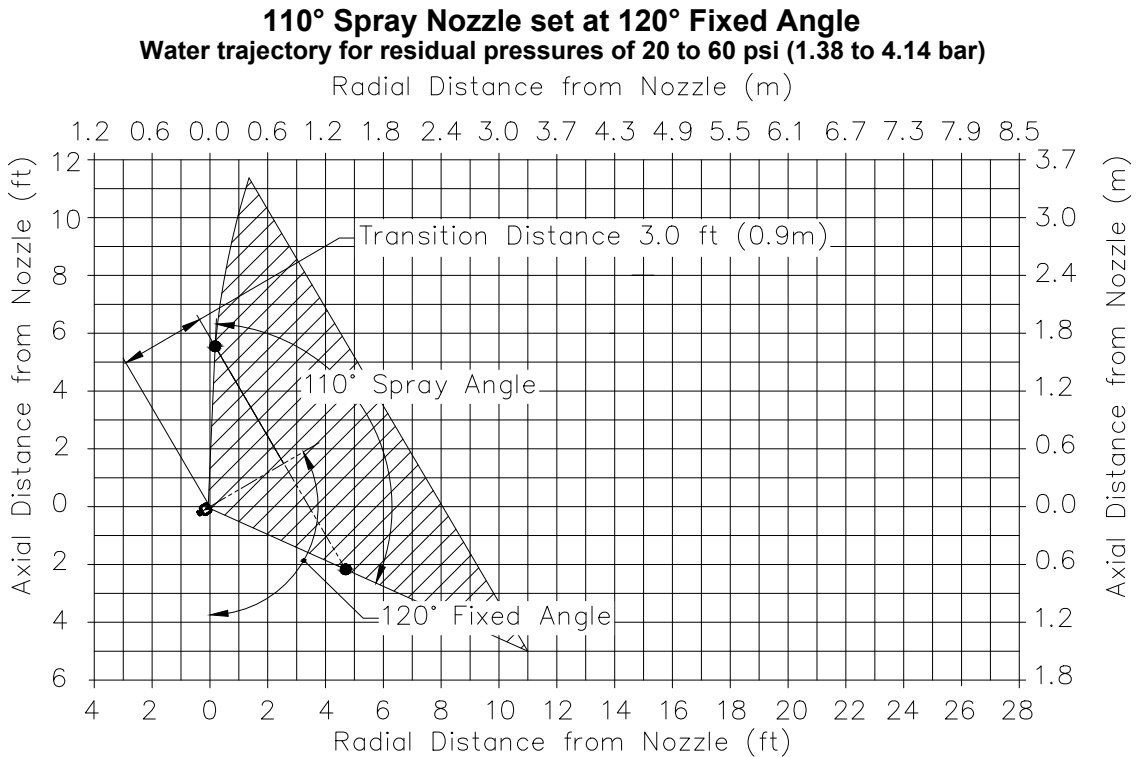
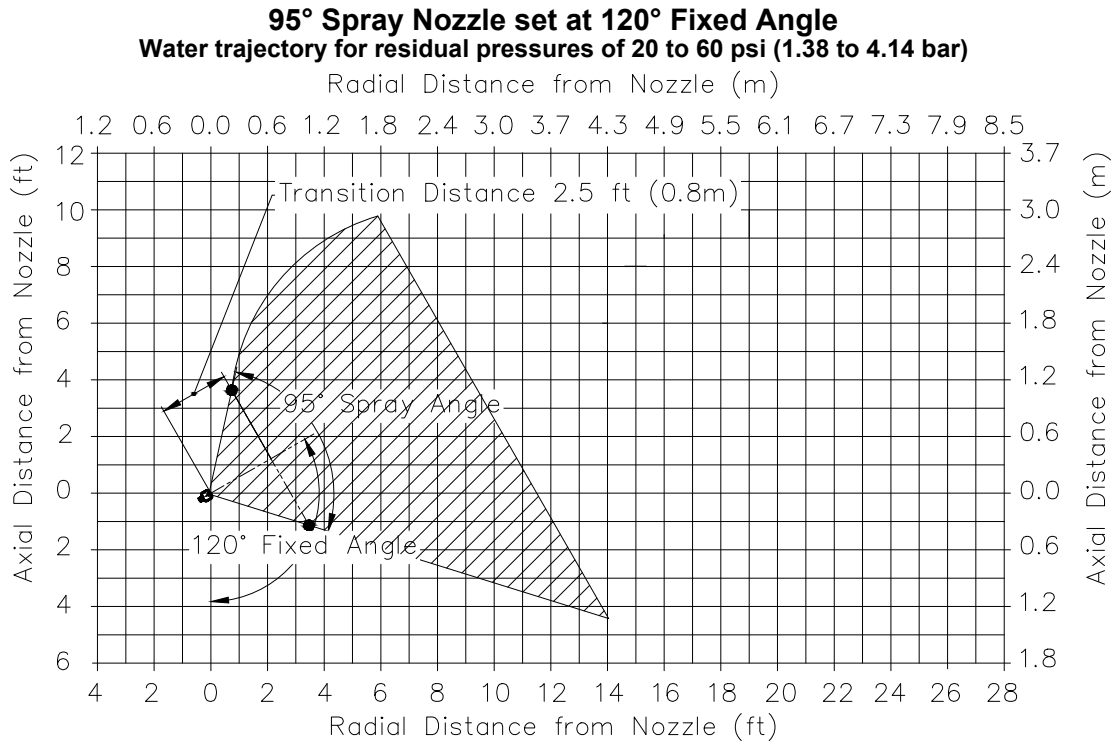

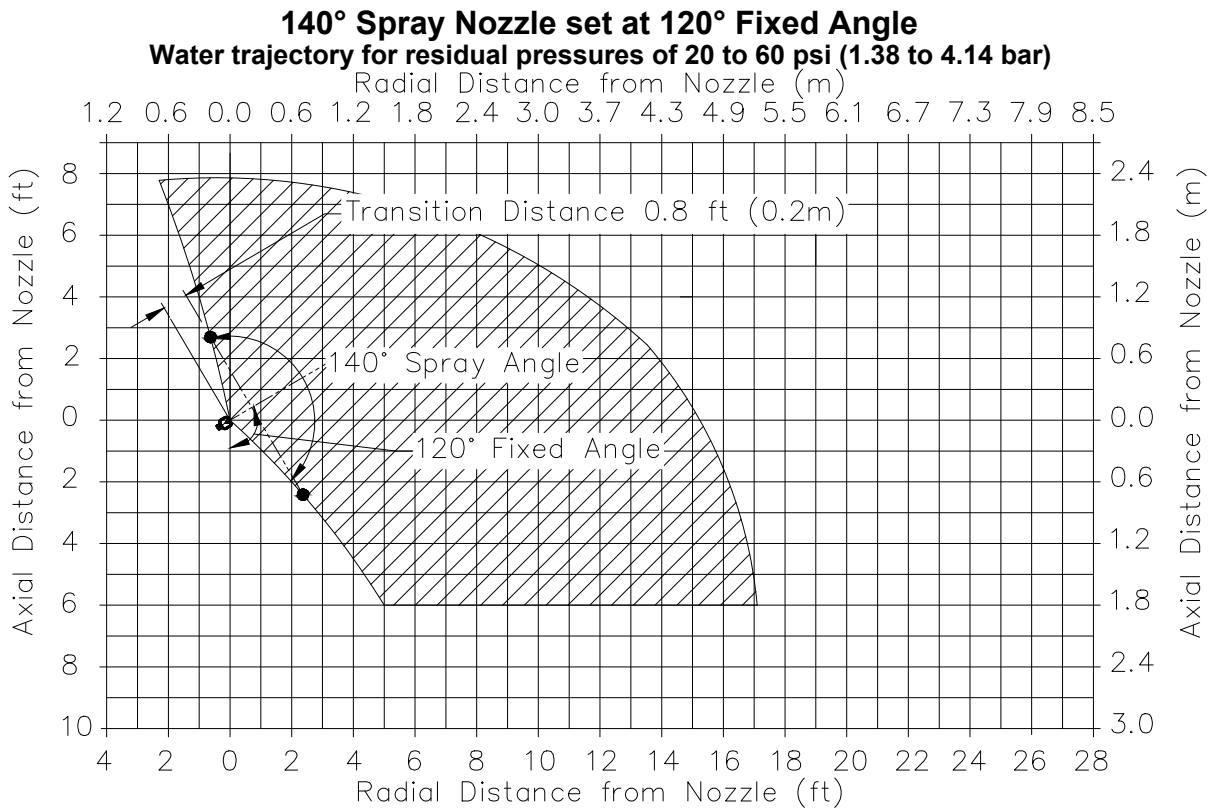
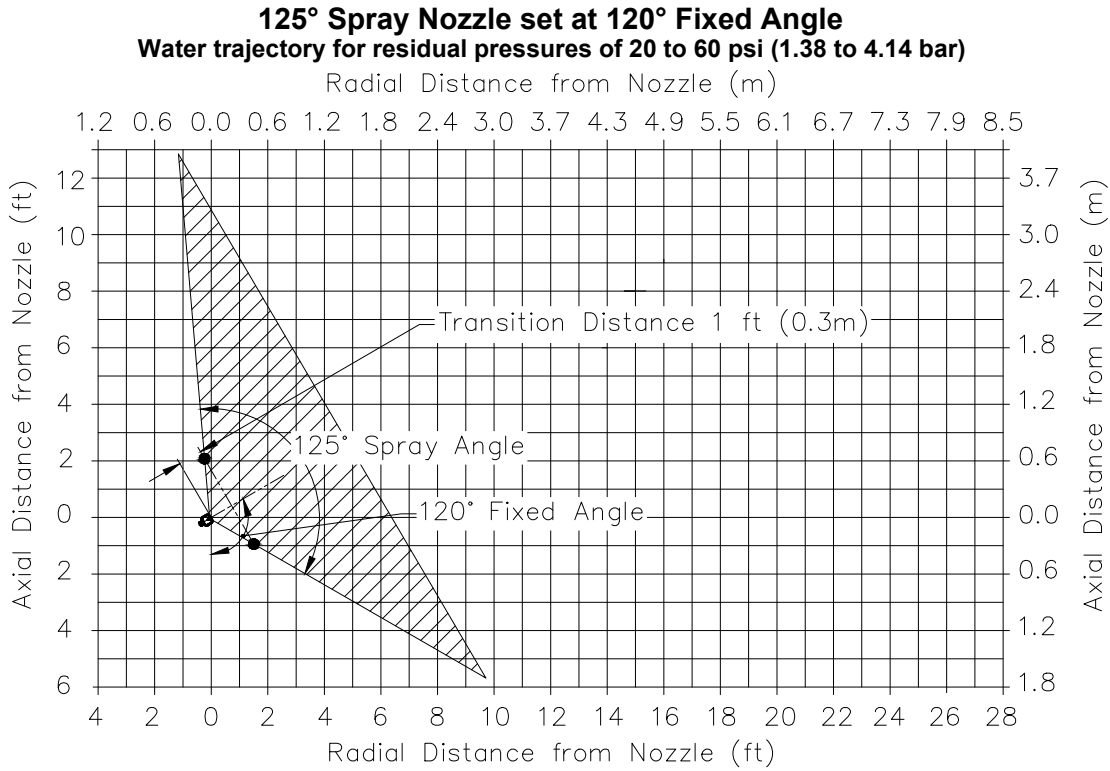

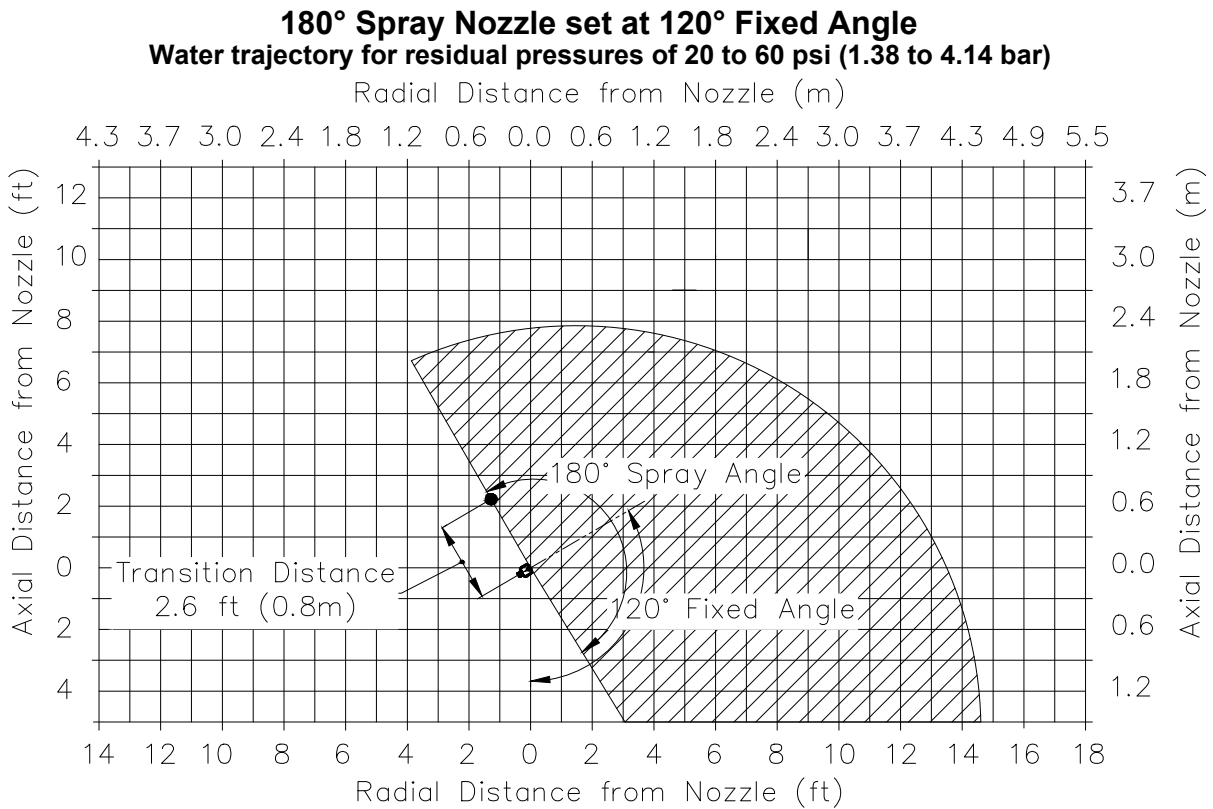
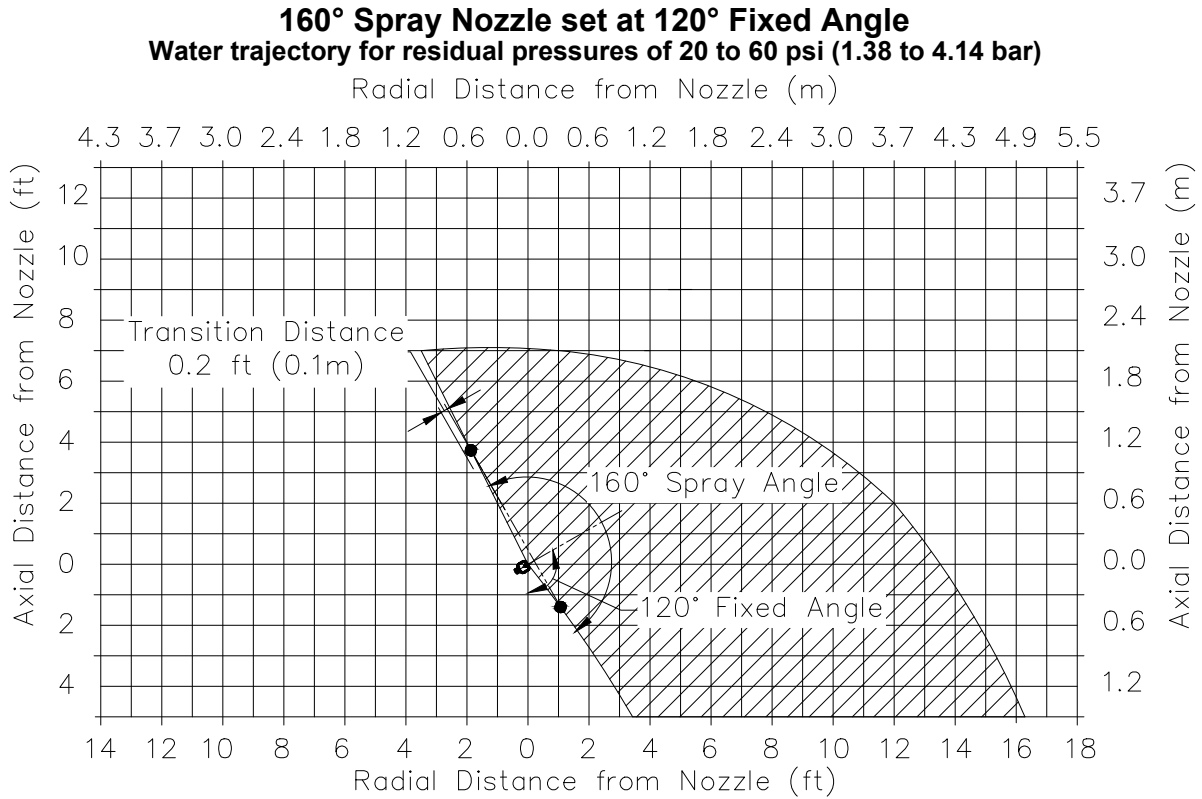

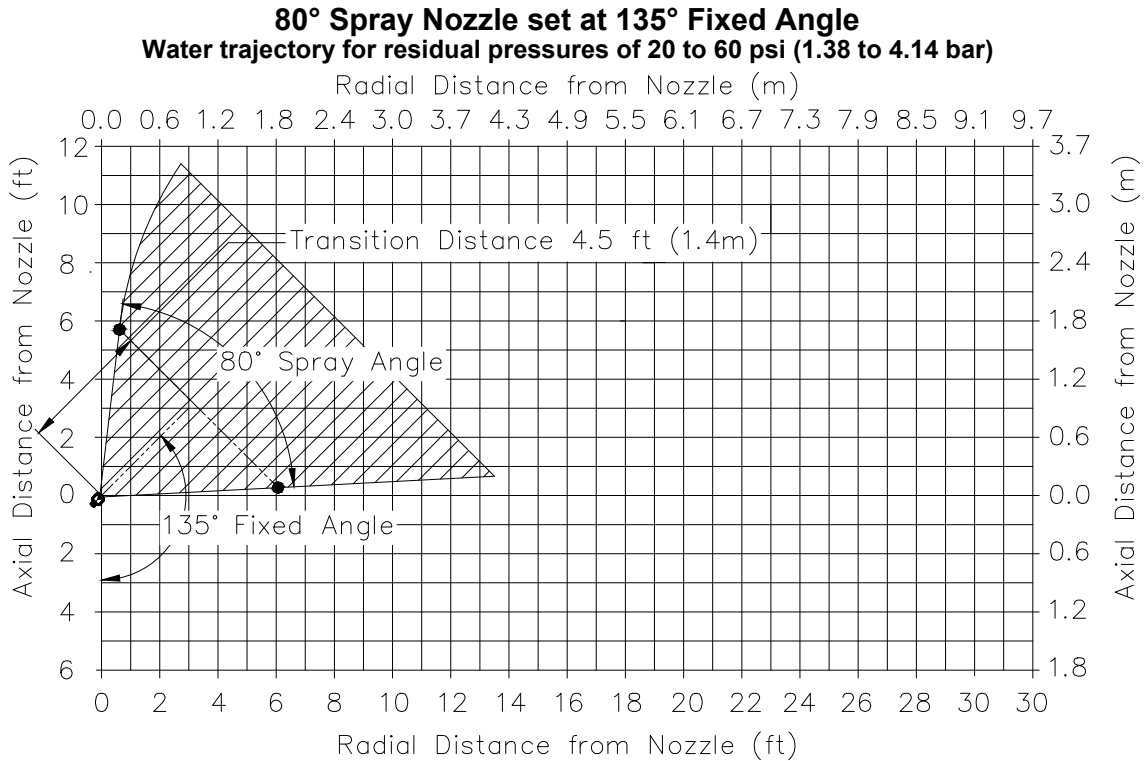
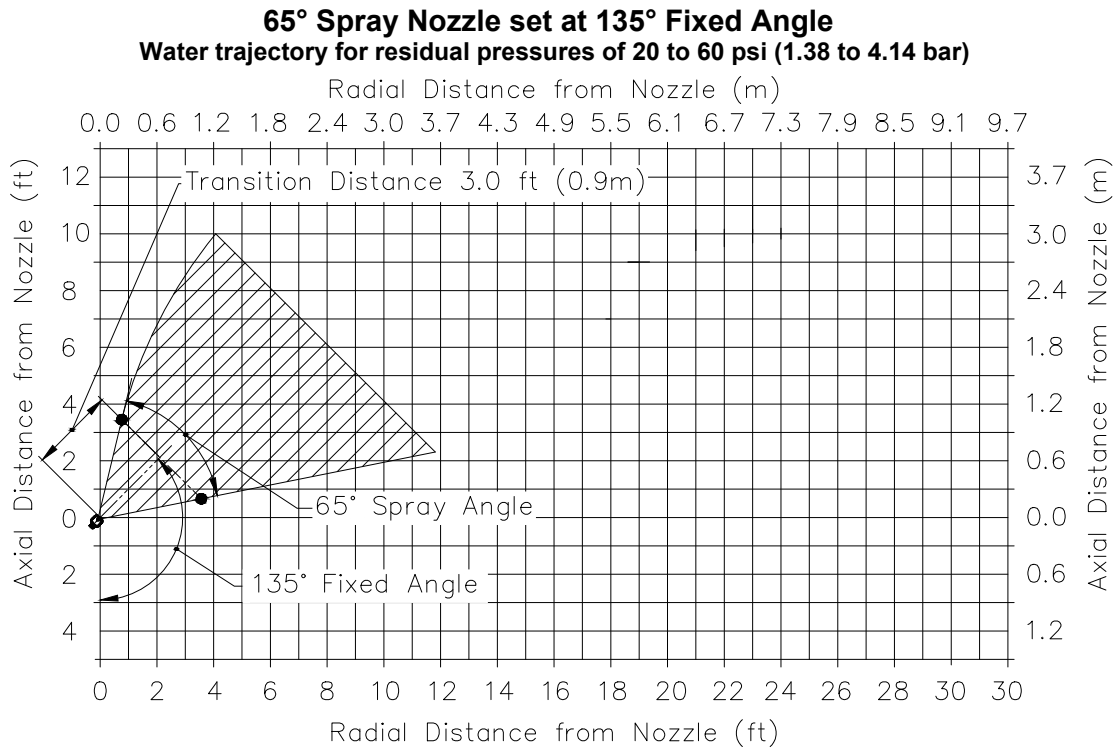

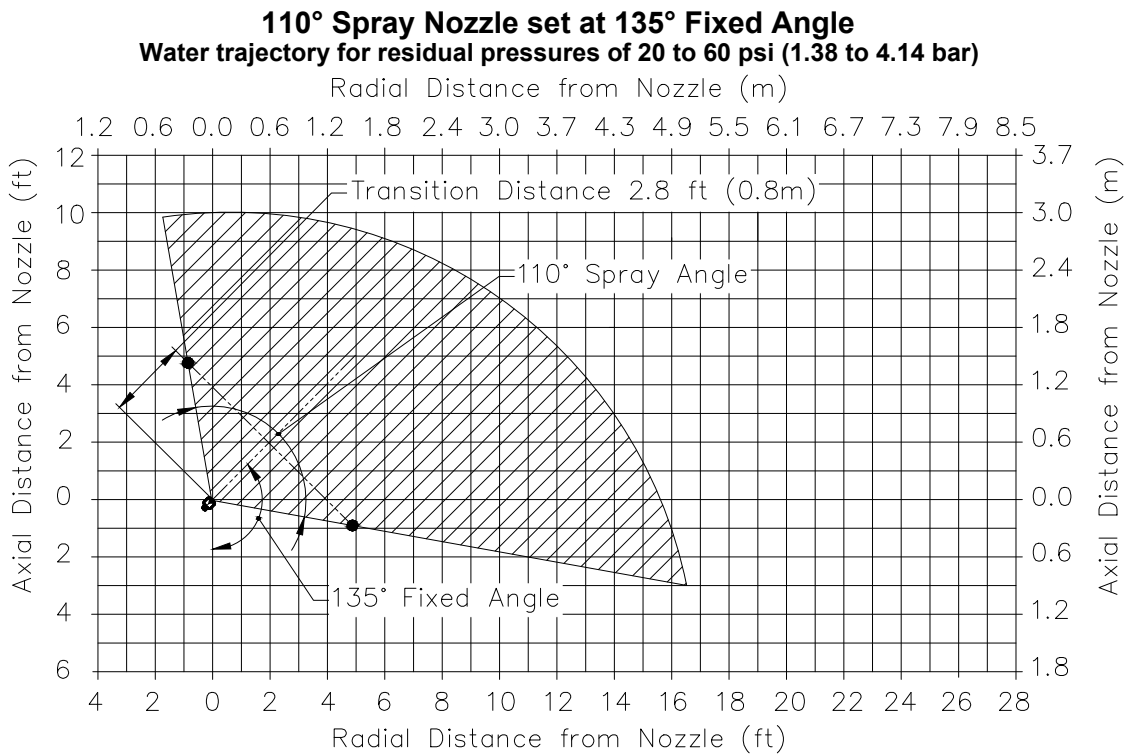
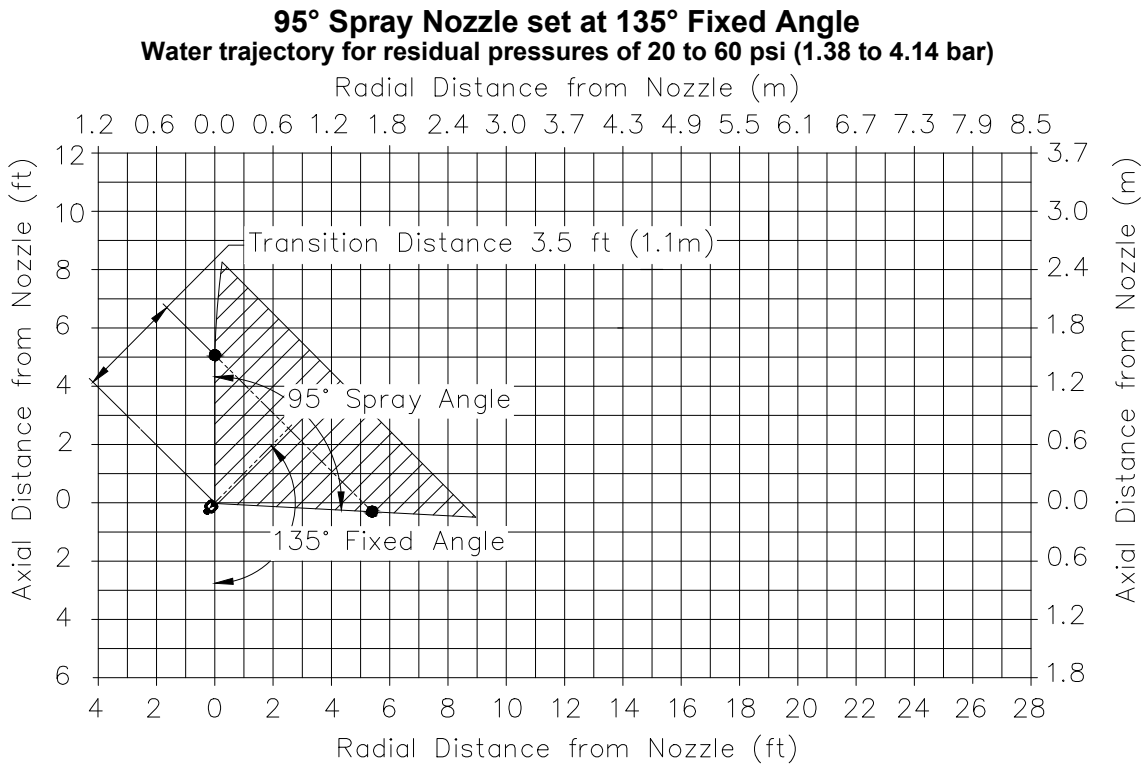

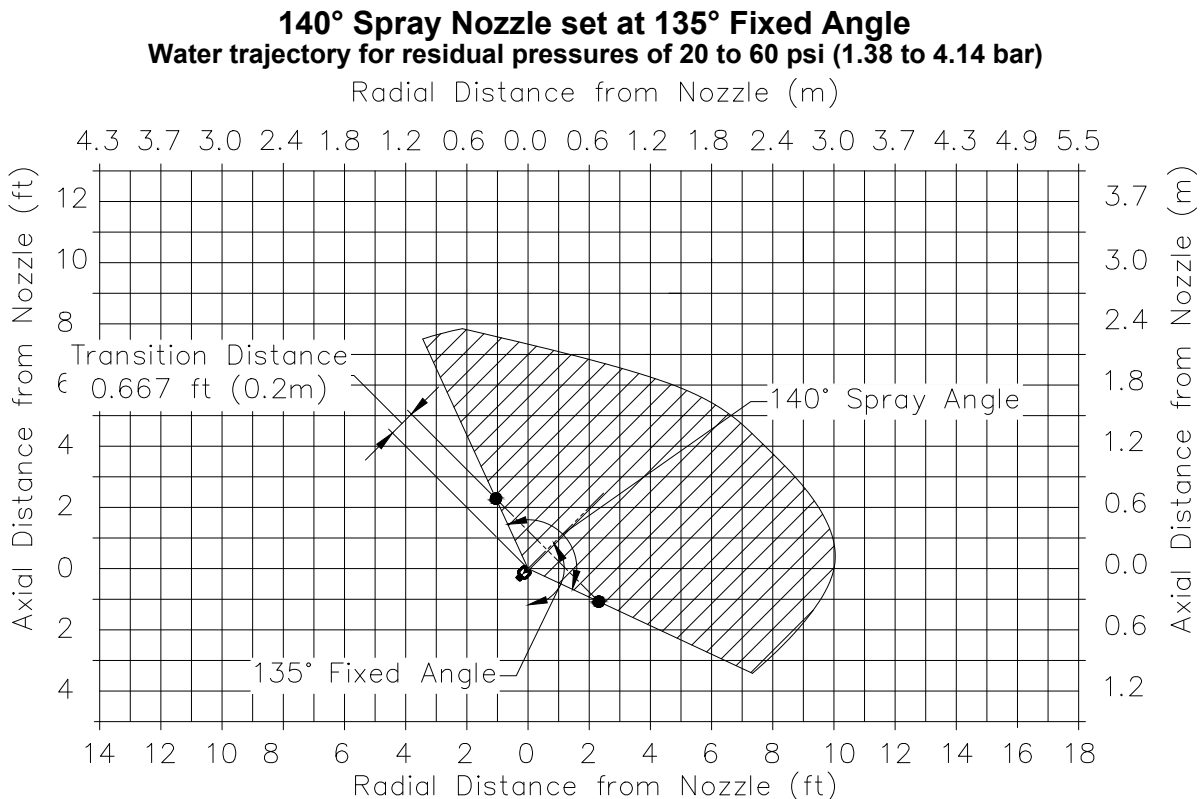
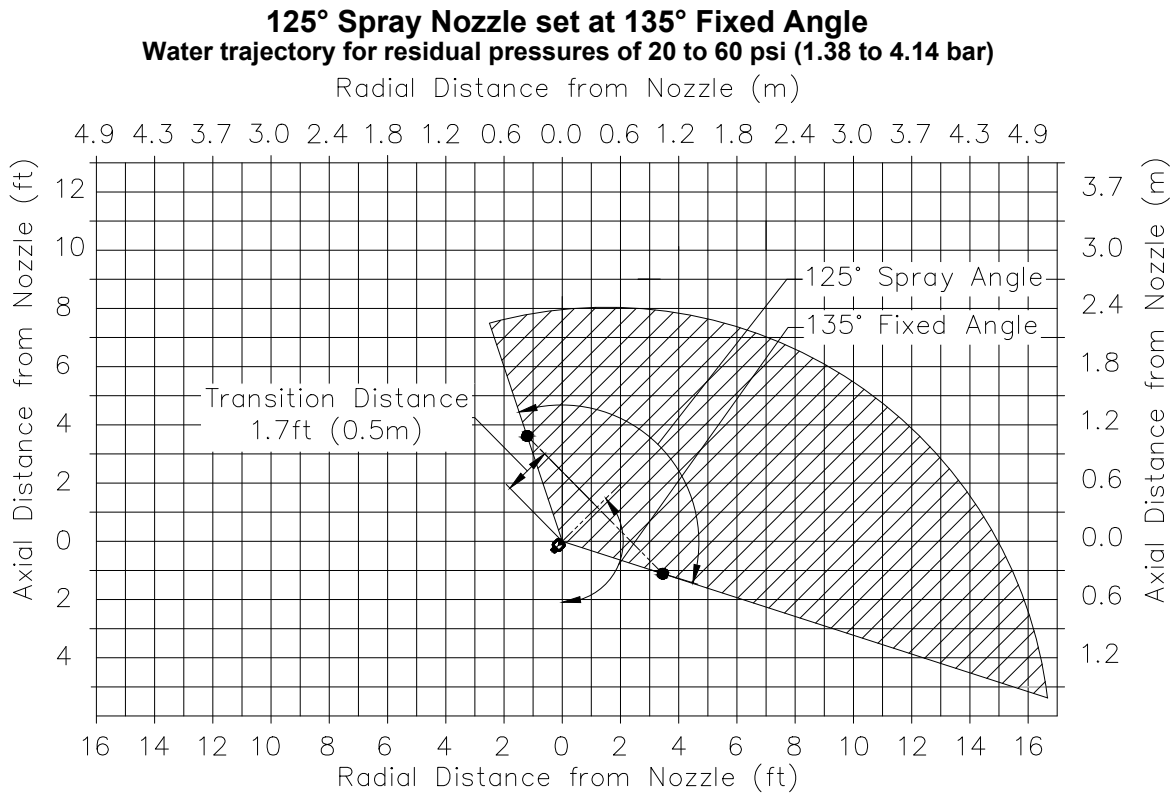

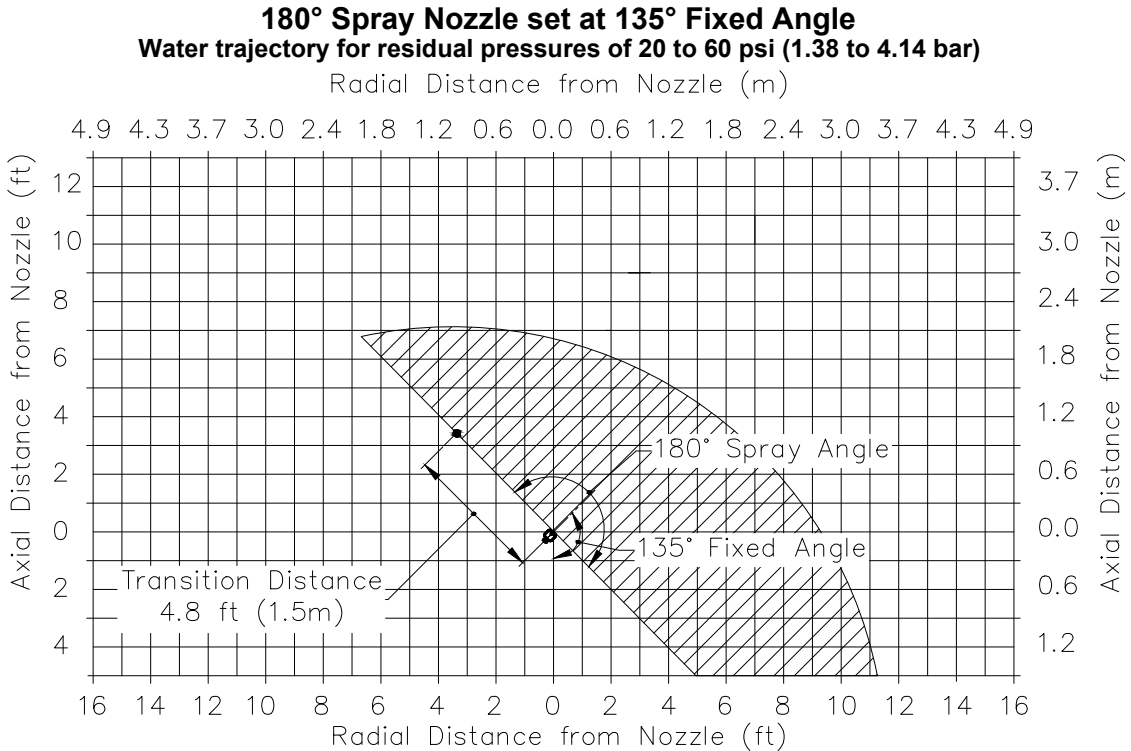
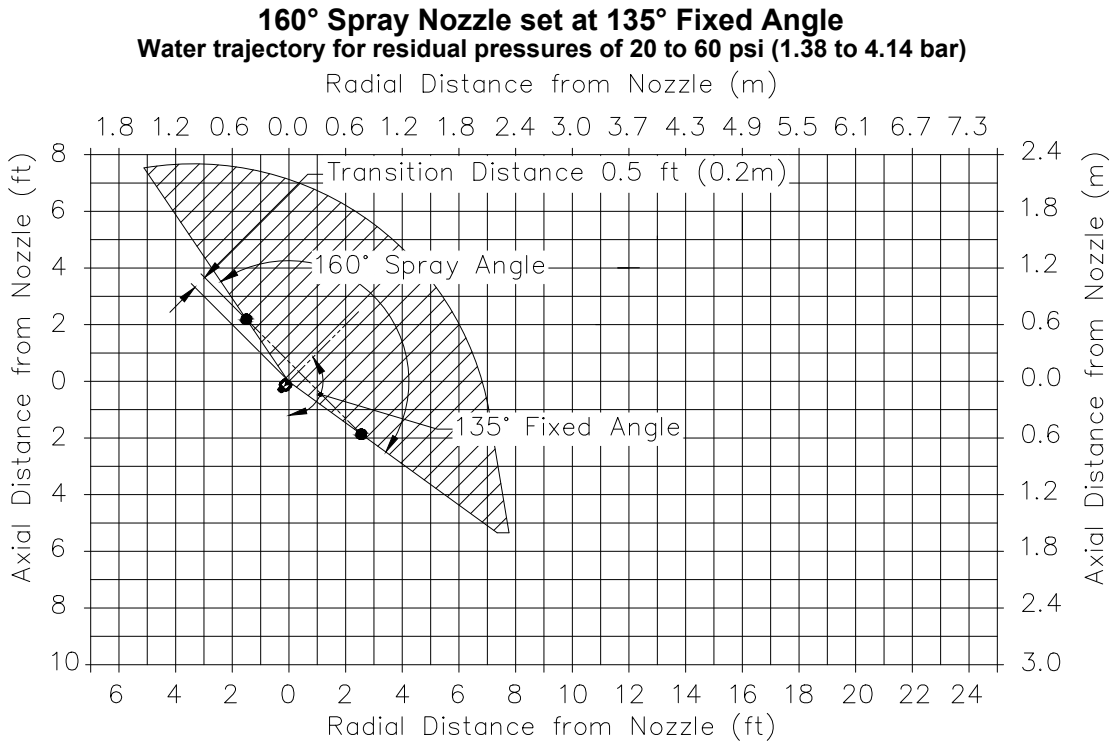

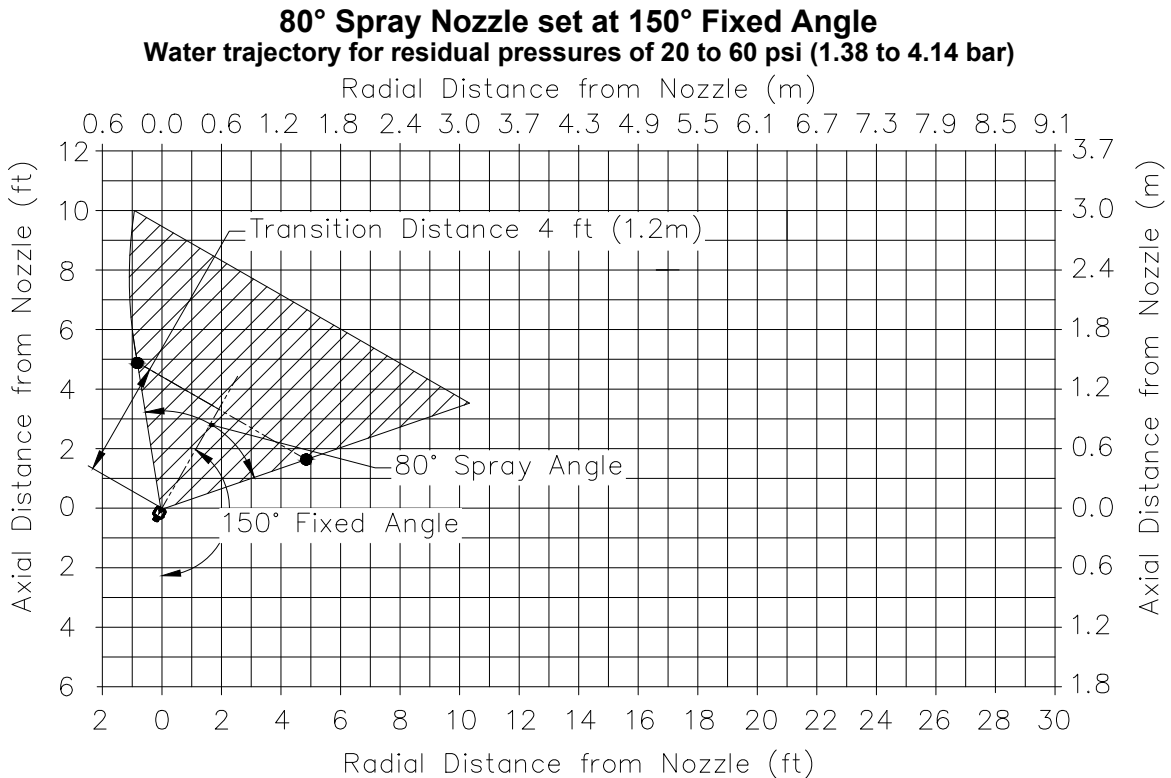
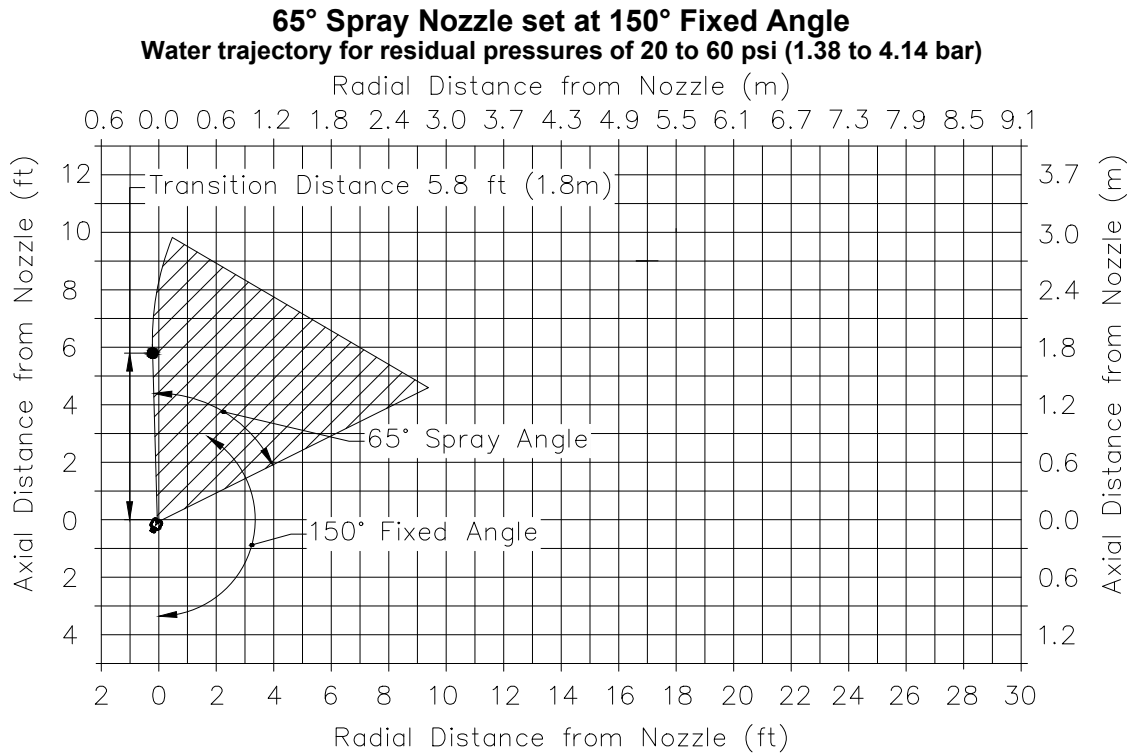

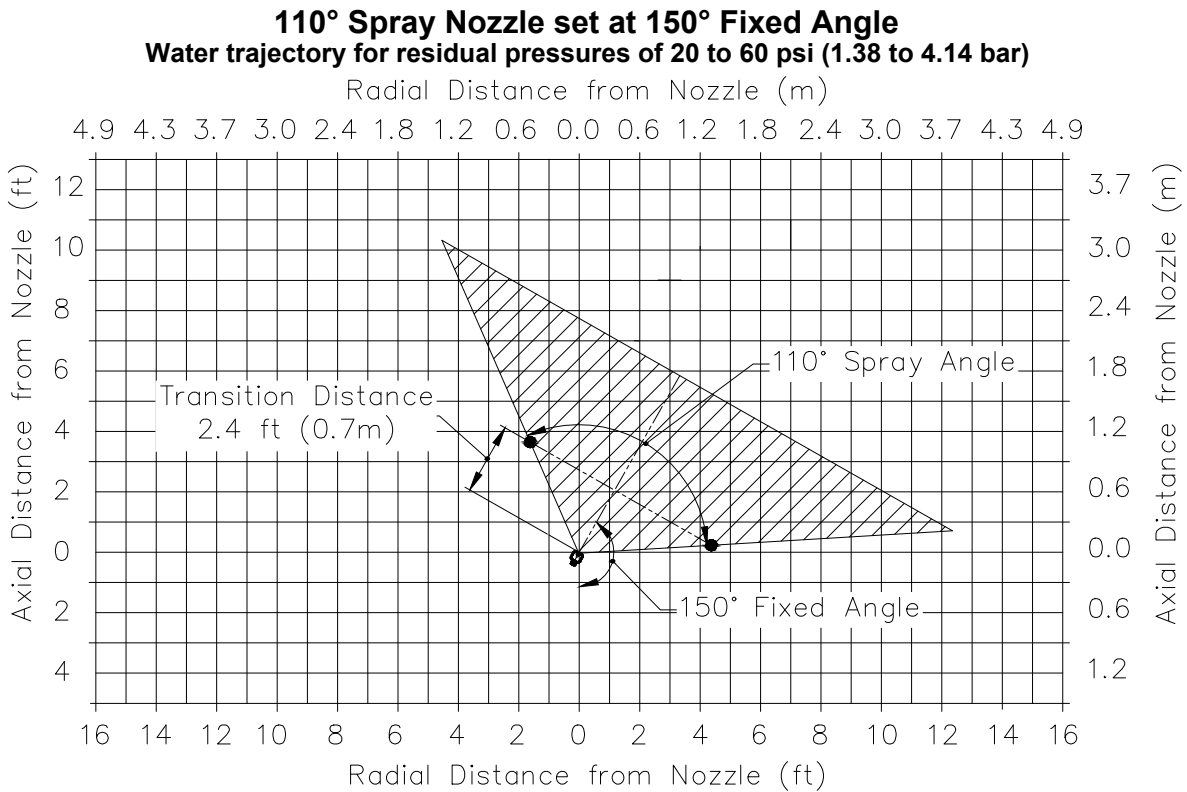
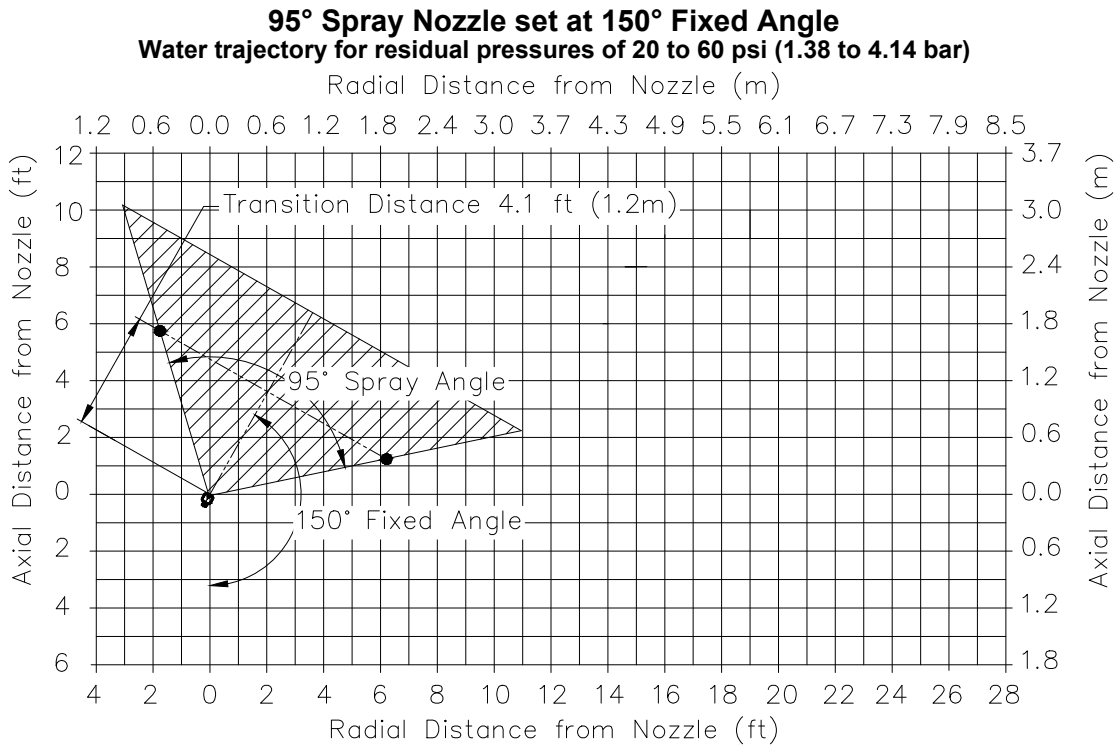

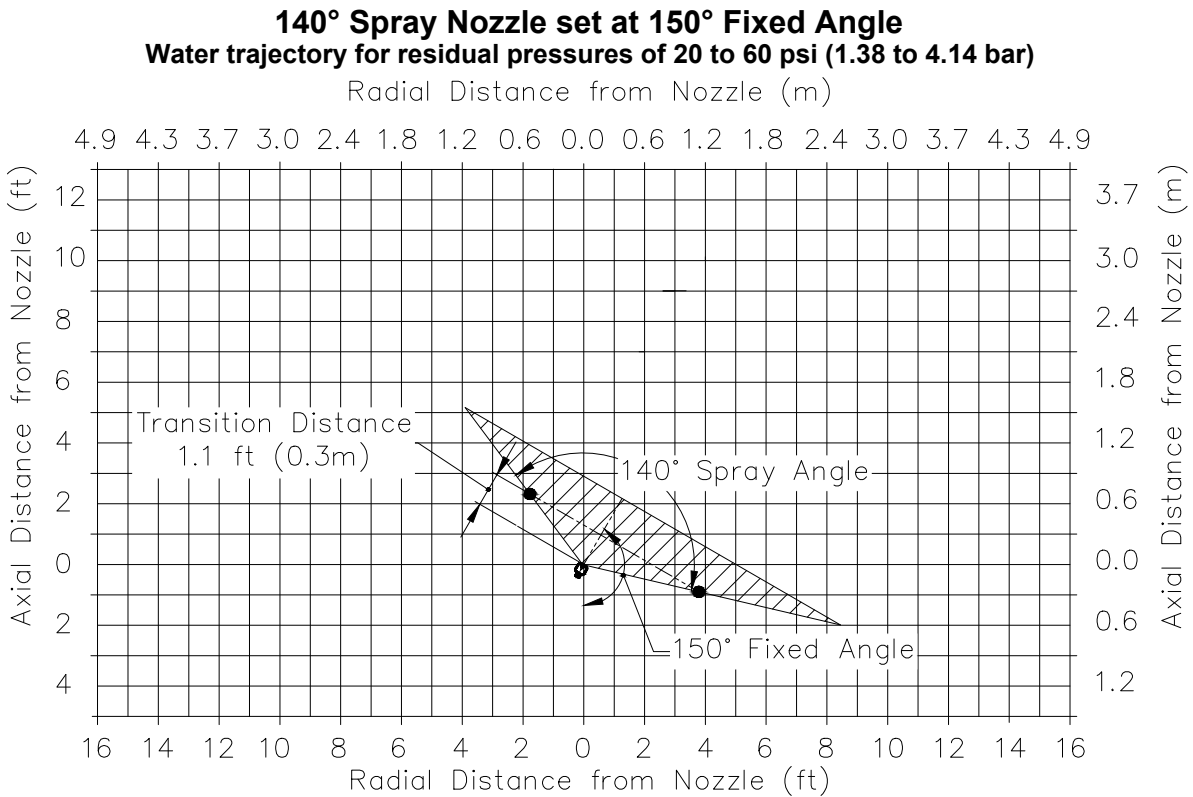
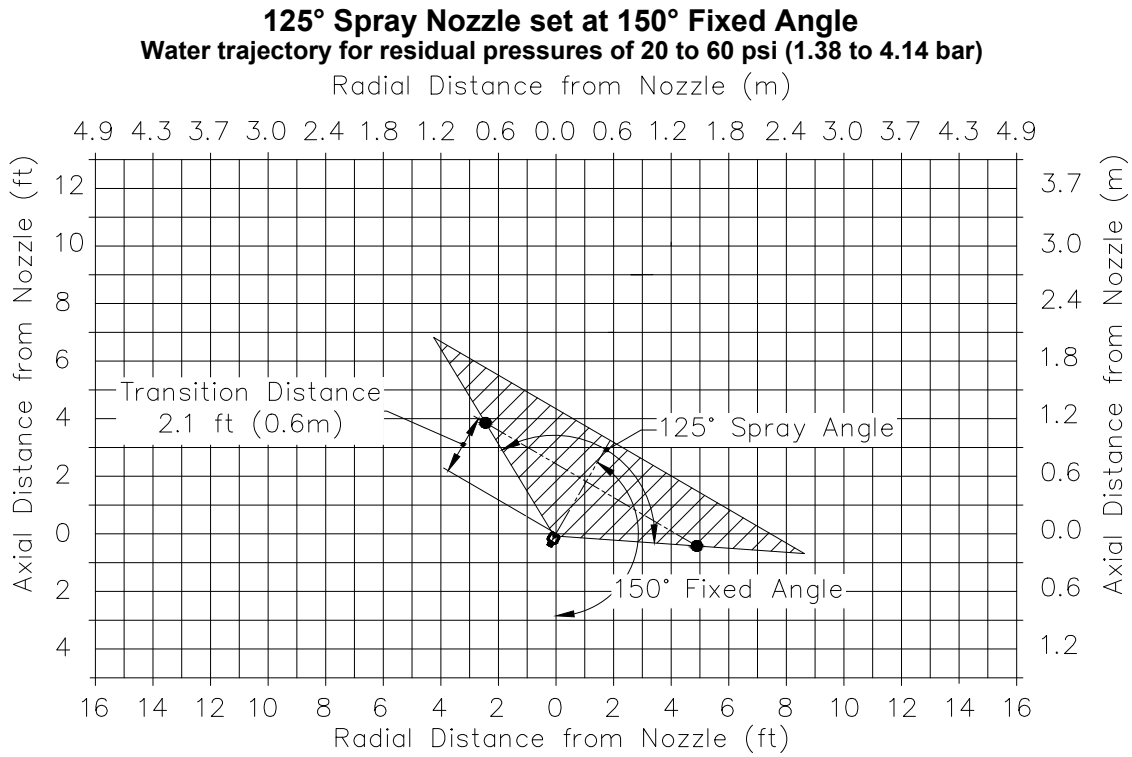

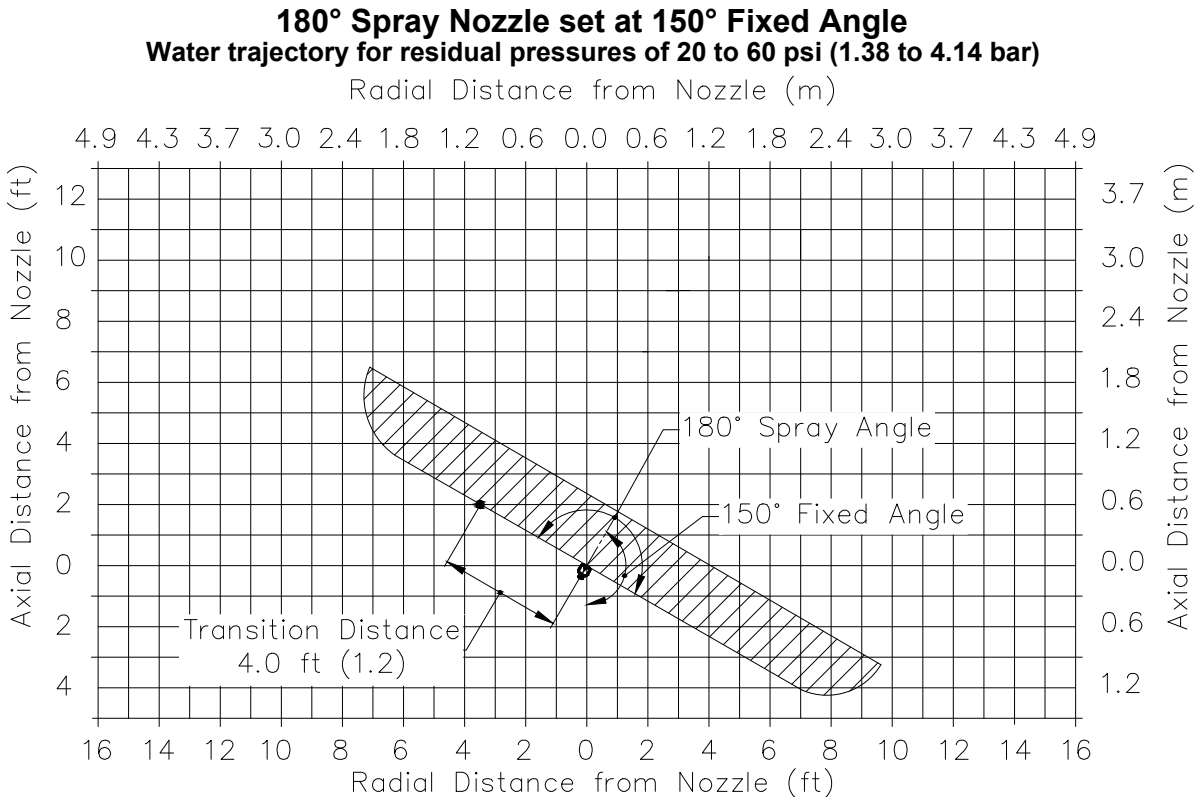
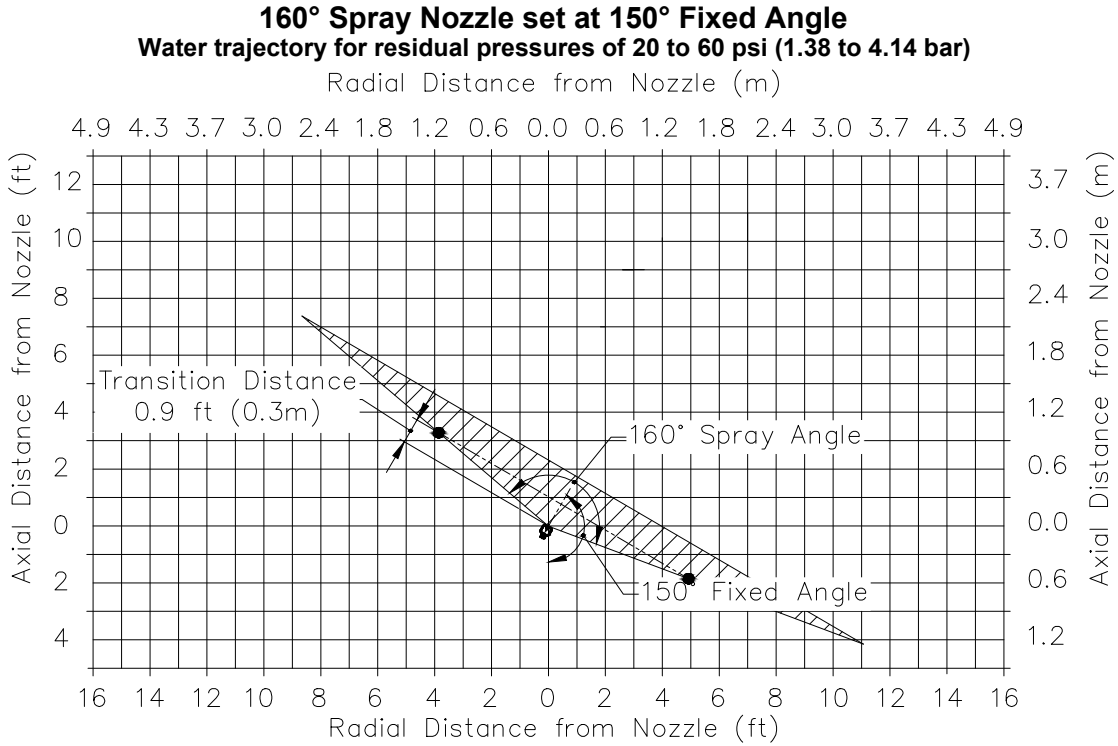

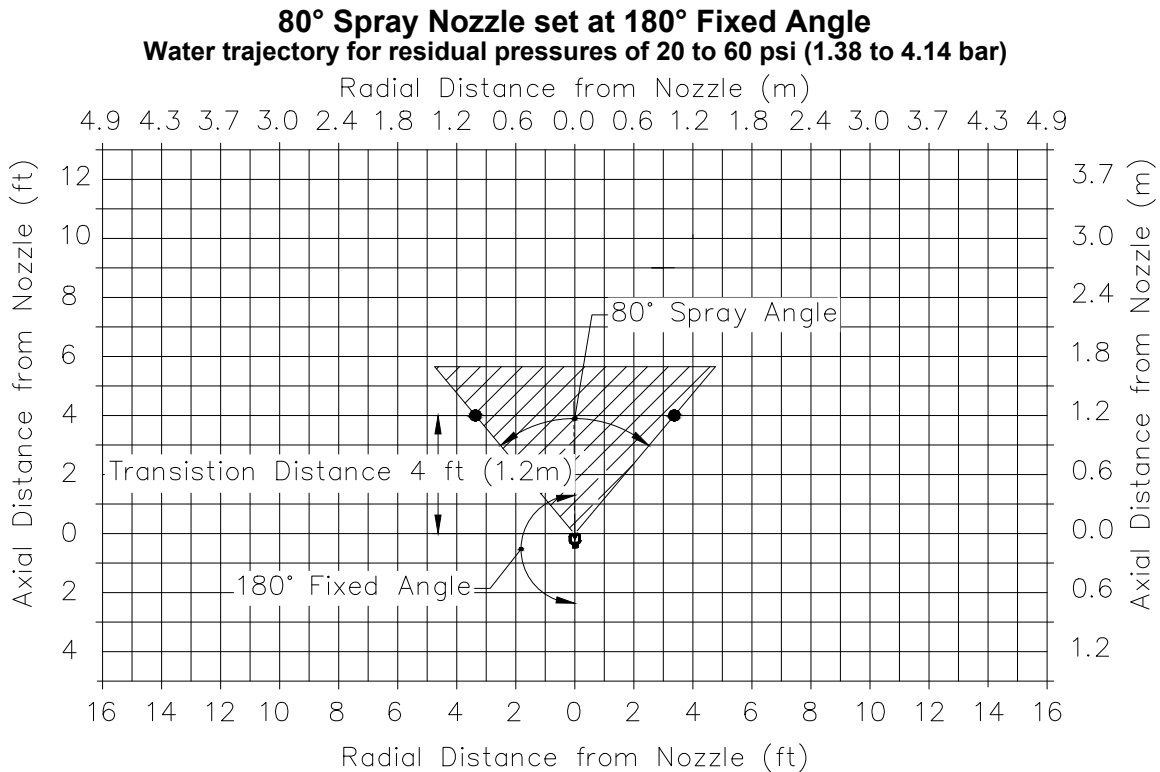
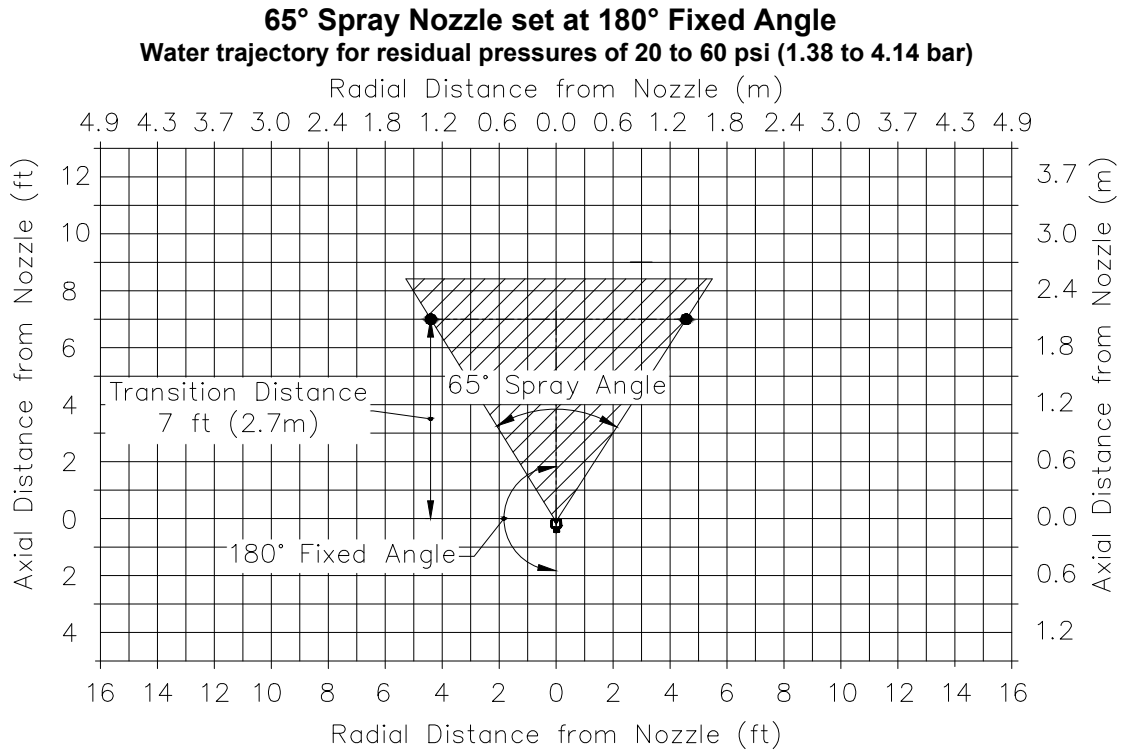

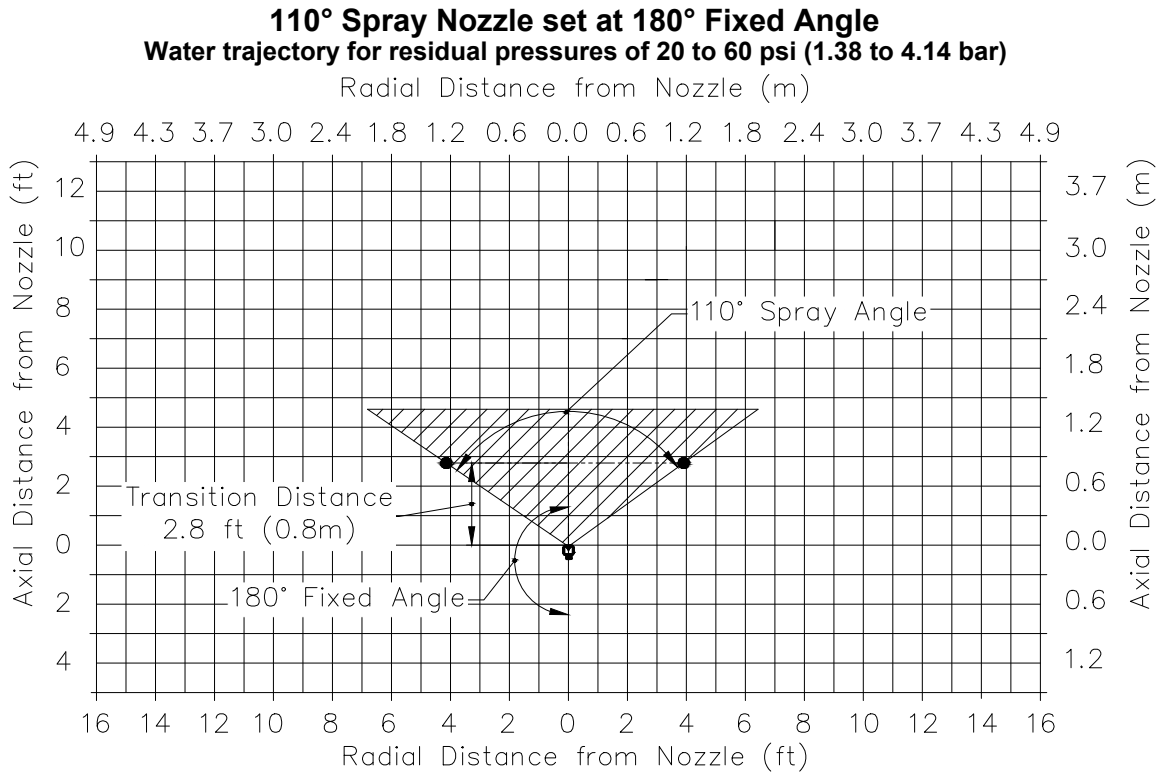
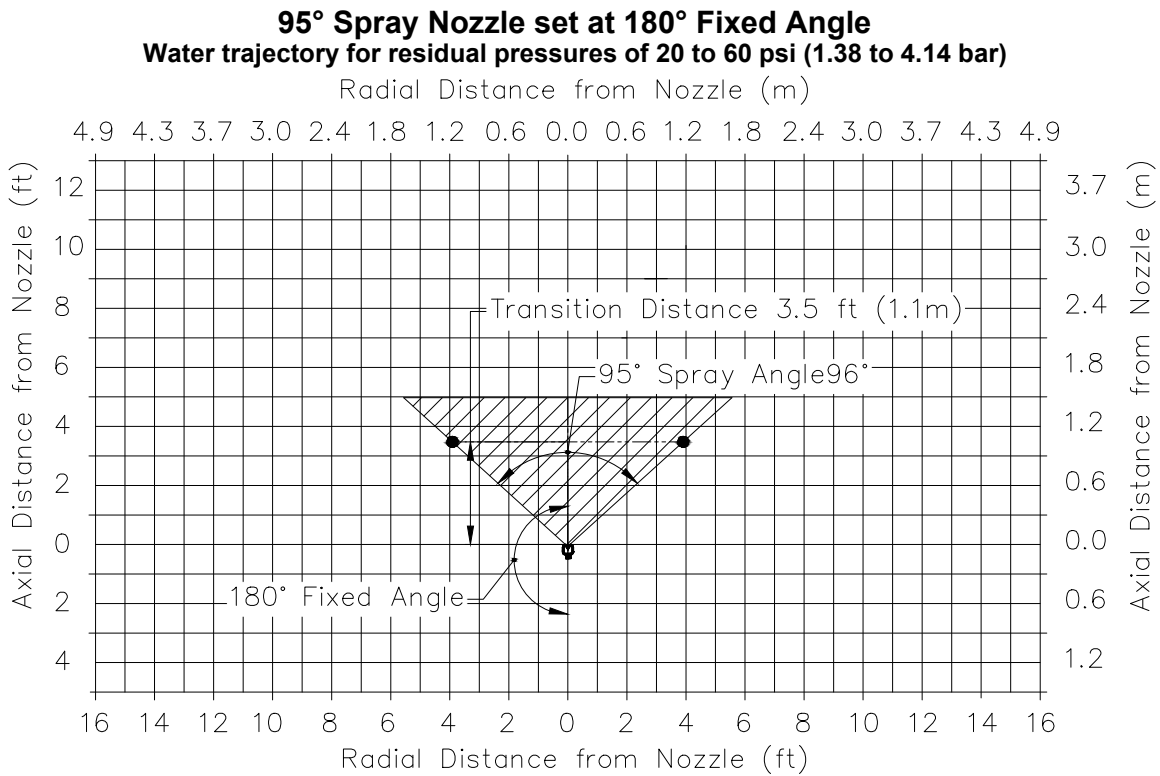

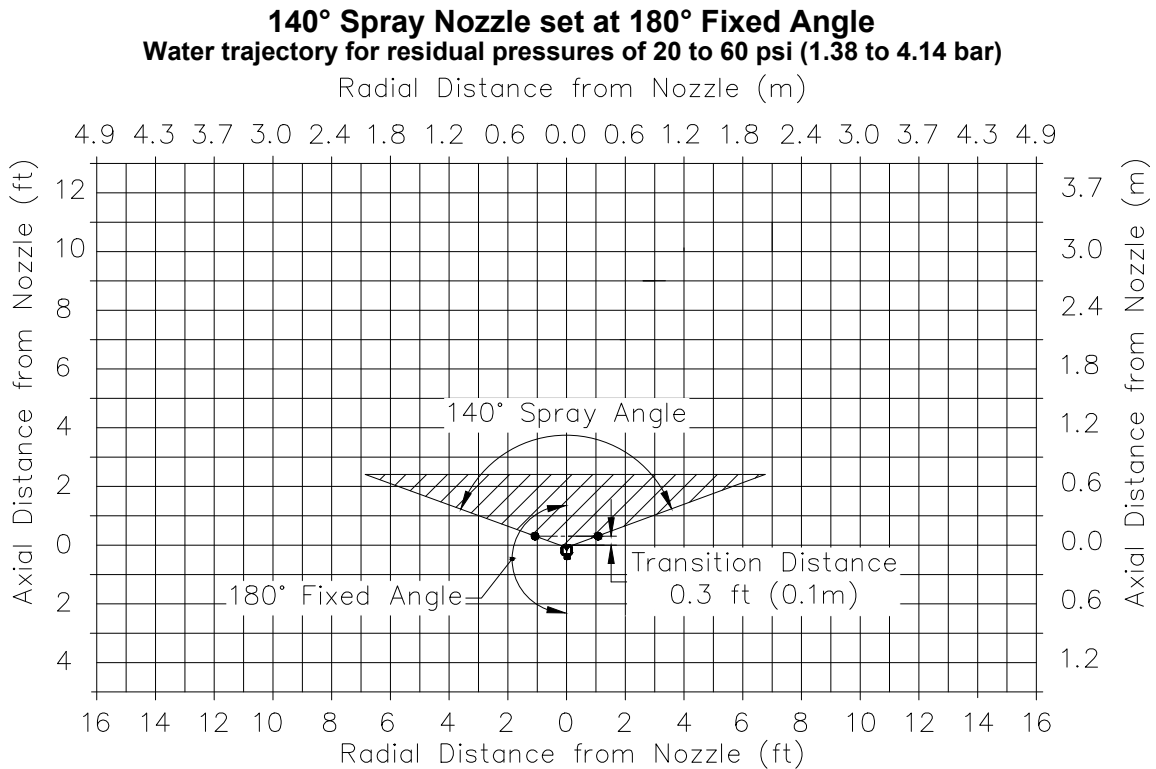
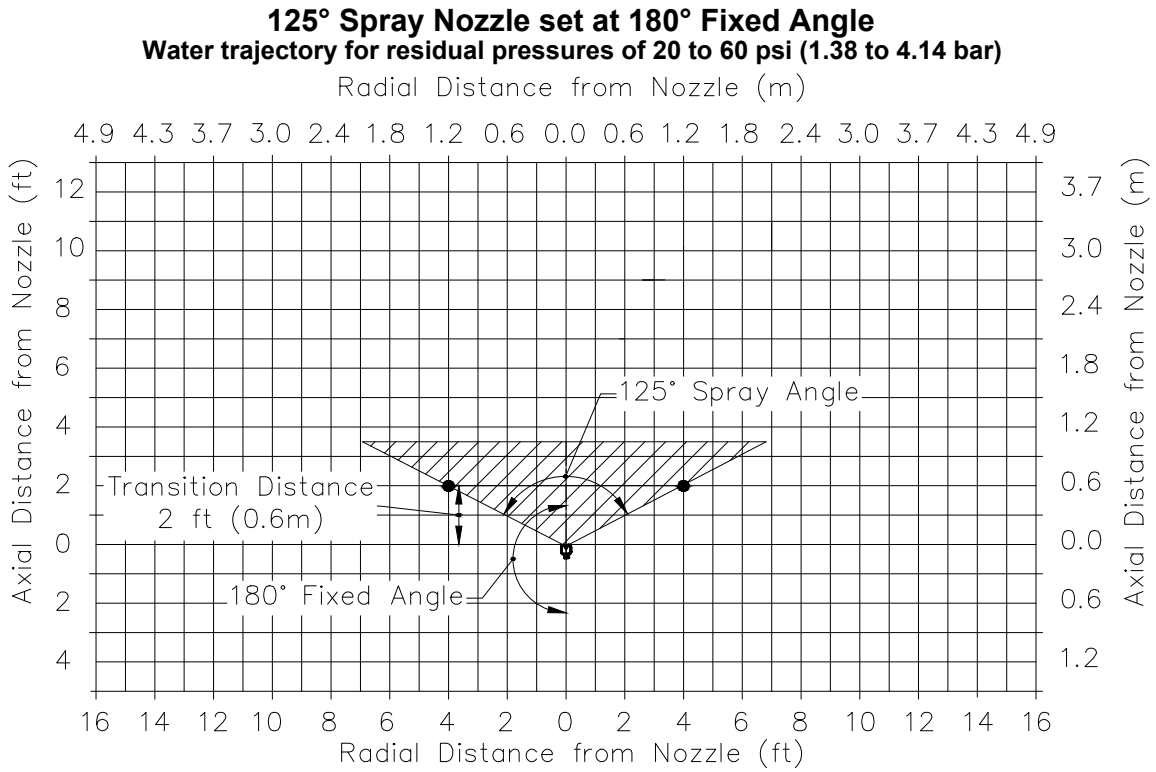

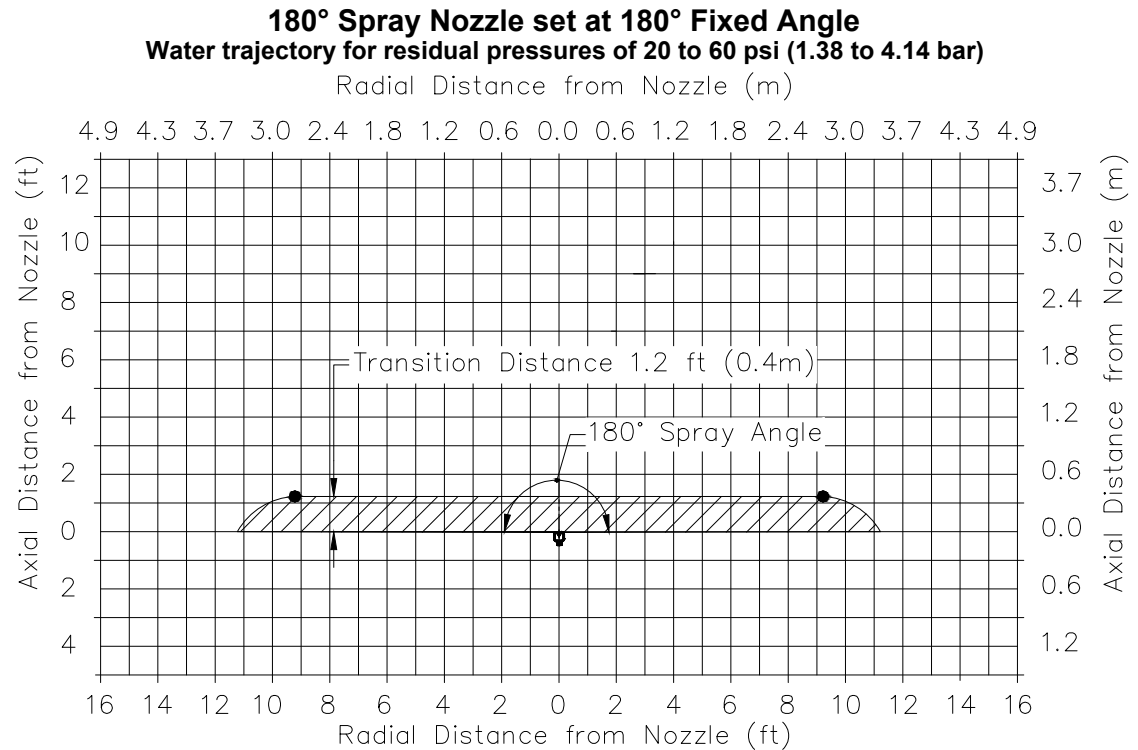
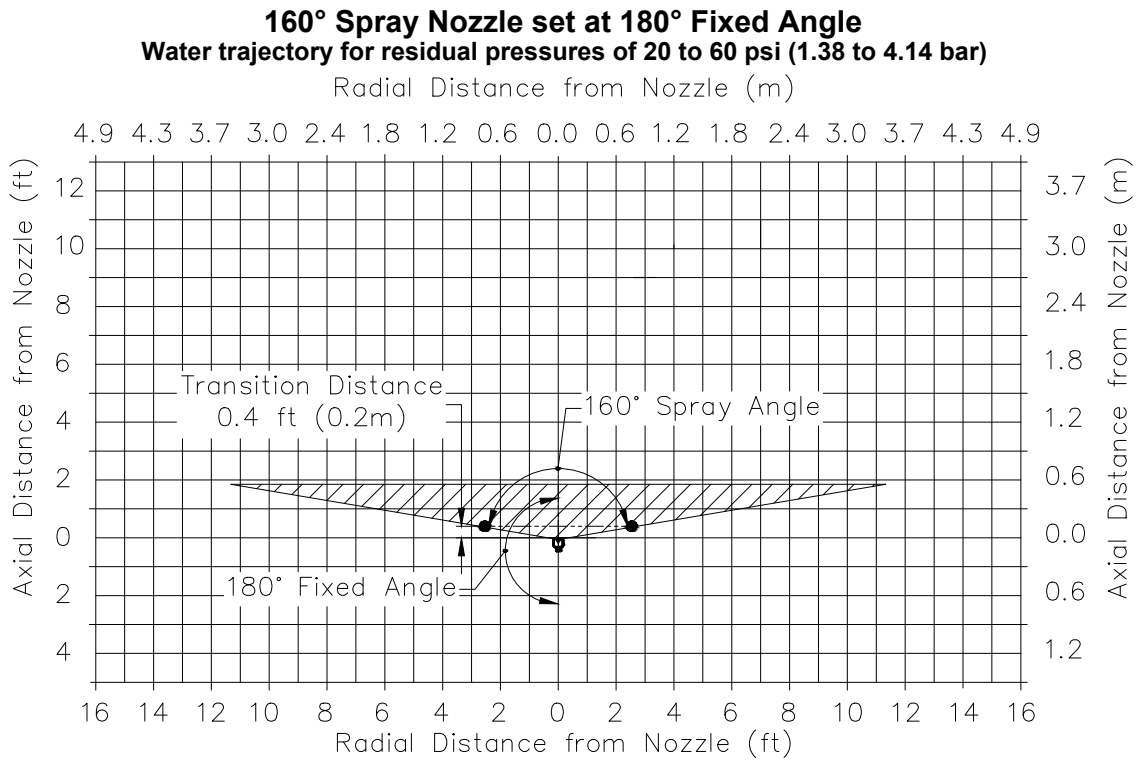

Model W2 Wrench



Any system maintenance or testing that involves placing a system out of service may eliminate the fire protection that is provided by the fire protection system. Notify any required authorities having jurisdiction and implement appropriate precautions prior to proceeding.

Prior to installation, nozzles should remain in the original cartons and packaging until used. This will minimize the potential for damage to nozzles that could cause improper operation or non-operation.

A stock of spare nozzles should be maintained to allow quick replacement of damaged nozzles. Failure to properly maintain nozzles may result in improper or impaired water distribution during a fire event.

Installation

Model MV Medium Velocity series spray nozzles are intended to be installed in accordance with NFPA standards and the requirements of applicable authorities having jurisdiction.

Model MV series spray nozzles must be installed with the Reliable Model W2 installation wrench. Any other wrench may damage the nozzle. Recommended installation torque is 8 to 18 lb/ft (11 to 24 N-m). Do not tighten nozzles over the maximum recommended installation torque. Exceeding the maximum recommended installation torque may cause impairment of the nozzle.

Note: NFPA 15 requires a main pipeline strainer for all systems utilizing nozzles with waterways less than 3/8 in. (9.5mm) and for any system where the water is likely to contain obstructive material.

Maintenance

Reliable Model MV Series nozzles should be inspected and the sprinkler system maintained in accordance with NFPA 25, as well as the requirements of any Authorities Having Jurisdiction.

Guarantee

For the guarantee, terms, and conditions, visit www.reliablesprinkler.com.

Ordering Information

Specify:

Nozzle

- Model MV Nozzle
- Finish
- K-Factor
- Nozzle Angle
- Blow-off Plug (optional)

Wrench

- Model W2

Ordering Information: Model MV Medium Velocity Series Spray Nozzles

4EØ YY KK AAA

Finish <u>YY</u>	K-Factor gpm/psi^{1/2} (L/min/bar^{1/2}) <u>KK</u>	Nozzle Angle <u>AAA</u>
11 = Brass	12 = 1.2 (17)	065 = 65°
43 = ENT	18 = 1.8 (26)	080 = 80°
	23 = 2.3 (33)	095 = 95°
	30 = 3.0 (43)	110 = 110°
	41 = 4.1 (59)	125 = 125°
	56 = 5.6 (80)	140 = 140°
	72 = 7.2 (104)	160 = 160°
		180 = 180°