

# Reliable®

## Model DH56 Dry Extended Coverage Horizontal Sidewall Sprinkler

cULus Listed

### Features

- Coverage for long and narrow light hazard spaces such as hallways, decks, and rooms
- Coverage area up to 28 ft (8.5m) long and 10 ft (3m) deep
- Available in four trim styles and a variety of finish combinations.

### Product Description

The Reliable Model DH56 Dry Extended Coverage Horizontal Sidewall Sprinkler is a quick-response sprinkler utilizing a sensitive 3mm glass bulb thermal element listed for use in light hazard applications.

Dry sprinklers are intended for use on wet, dry, and preaction systems to protect indoor and outdoor areas that are subject to freezing. When used on wet systems, it is important that a minimum exposed length of barrel inside the face of the wall or insulation is provided to offset conduction of potentially freezing temperatures from the unconditioned (sprinkler) end along the barrel. See Figure 6 for guidelines on using dry sprinklers on wet systems.

Environments where dry sprinklers are employed are often corrosive. For this reason, Model DH56 dry sprinklers have a special wax fillet placed in the gap between the cup that supports the bulb and the wrenching boss. This wax prevents contaminants from entering the internal portion of the drop nipple and must not be removed.



DH56 Dry EC HSW with standard escutcheon

### Application

The Model DH56 is a horizontal sidewall dry sprinkler intended for installation in light hazard occupancies in accordance with NFPA 13. These sprinklers are designed to provide fire protection in long and narrow spaces such as hallways, corridors, decks and rooms up to 28 feet (8.5m) wide and 10 feet (3m) deep. Model DH56 sprinklers are rated for 250 psi (17.2 bar) and can be mounted between 4 and 12 inches (102 and 305mm) down from the ceiling.

Table A

Sprinkler Model	Max. Working Pressure psi (bar)	Maximum Coverage Area Width x Length ft x ft (m x m)	Flow Rate gpm (L/min)	Pressure psi (bar)	Sprinkler Identification Number (SIN)
DH56 Dry EC	250 (17.2)	28 x 8 (8.5 x 2.4)	23 (87.1)	16.9 (1.2)	RA1664
		28 x 10 (8.5 x 3)	28 (106)	25 (1.7)	

**Technical Specifications**

**Style:**

Extended Coverage  
Horizontal Sidewall

**Threads:** 1" NPT or ISO7-1R1

**Nominal K-Factor:** 5.6 (80)

**Max. Working Pressure:** 250 psi (17.2 bar)

**Max. Spacing:** 28 ft (8.5m)

**Min. Spacing:** 16 ft (4.9m)

**Material Specifications**

**Inlet Fitting:** Brass Alloy

**Flip Disk:** Brass Alloy

**Seal:** PTFE Coated Belleville Spring

**Outer Tube:** Galvanized Steel Pipe

**Sprinkler Frame:** Brass Alloy

**Bulb Insert:** Copper Alloy

**Thermal Element:** Glass Bulb

**Deflector:** Bronze Alloy

**Load Screw:** Brass Alloy

**Sprinkler Finishes**

See finish combination tables on following pages

**Sensitivity**

Quick Response

**Temperature Ratings**

155°F (68°C)

175°F (79°C)

200°F (93°C)

**Recessed Escutcheons/Cover Plates**

Standard Escutcheon

HB Escutcheon

FP Escutcheon

SWC Cover Plate

**Listings and Approvals**

cULus Listed for Light Hazard



Shown here with standard escutcheon. See pages 3-6 for additional trim styles

**Model DH56 EC HSW Coverage Area**

**Figure 1**

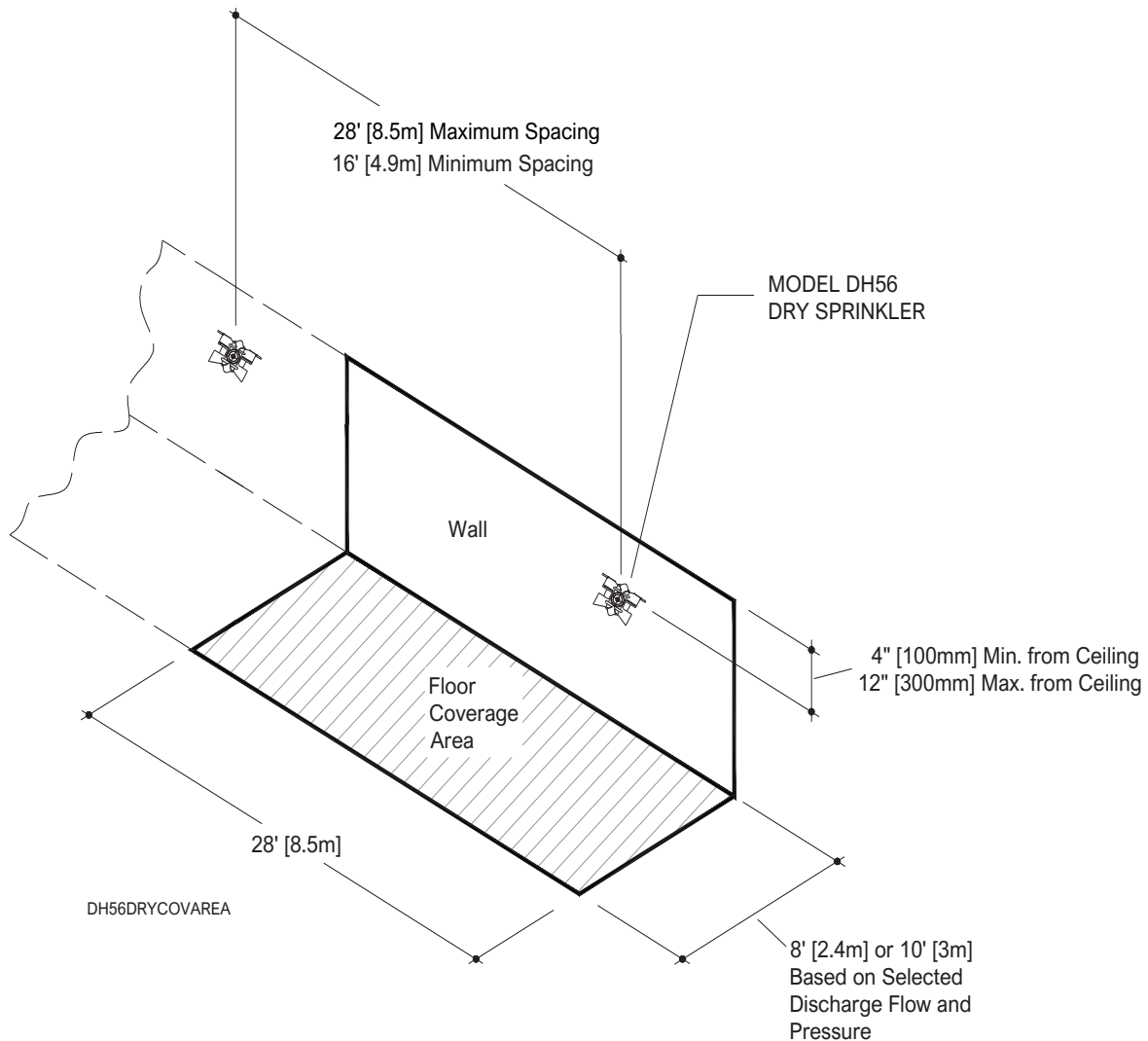

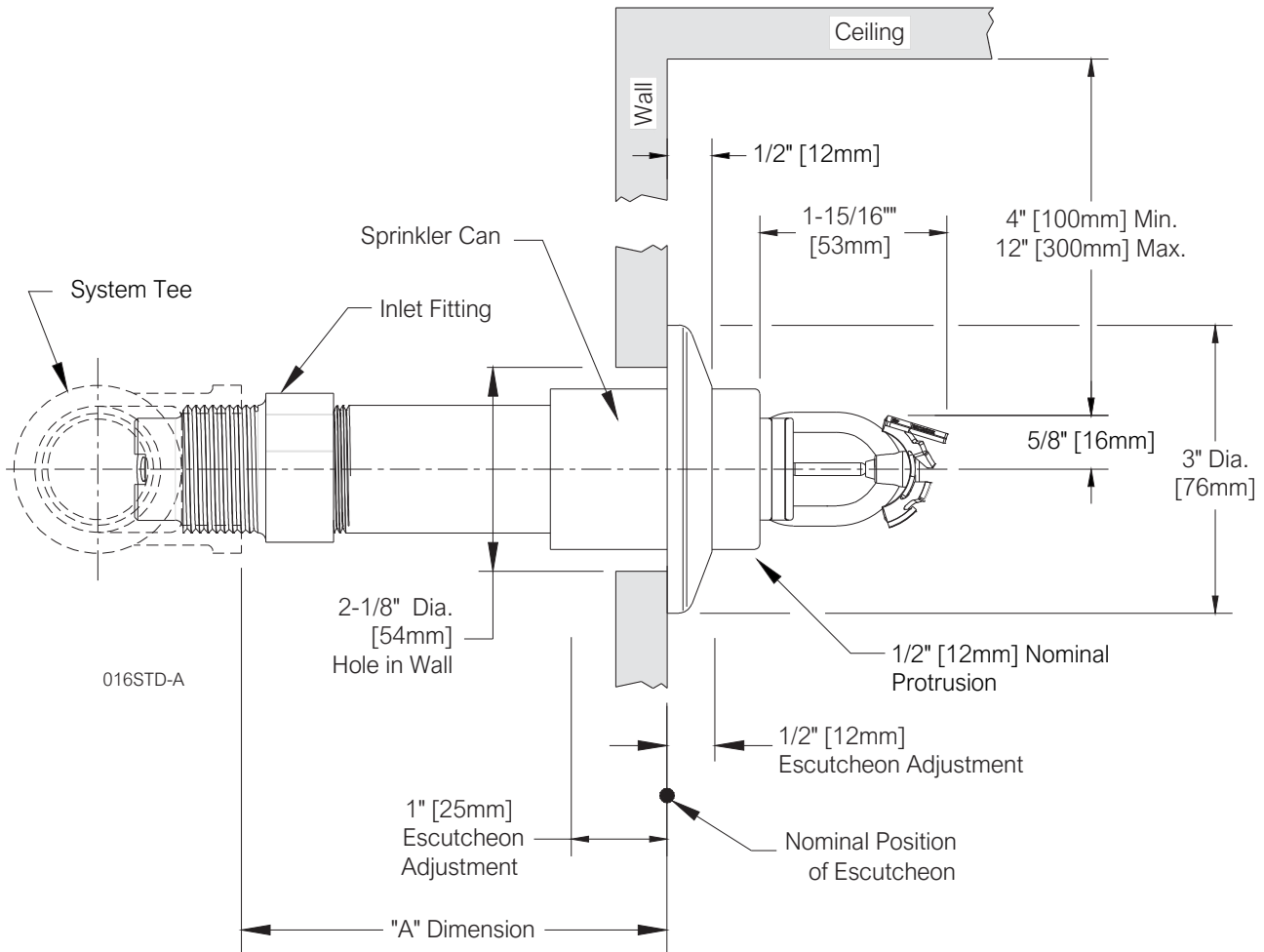

"A" Dimension: 2" to 48" (50mm to 1200mm) in 1/4" (6mm) increments

Finish Combinations: Standard Escutcheon	
Sprinkler	Escutcheon <sup>(2)(3)</sup>
Bronze	Polished Stainless Steel
Bronze	Laquered Brass
Chrome	Polished Stainless Steel
White Polyester <sup>(1)</sup>	White Polyester
Black Polyester <sup>(1)</sup>	Black Polyester
Custom Color Polyester <sup>(1)</sup>	Custom Color Polyester
Electroless Nickel PTFE <sup>(1)</sup>	Polished Stainless Steel



**Notes:**

1. UL Listed as Corrosion Resistant.
2. Escutcheons do not carry corrosion resistant listings.
3. Base material is 316 stainless steel.

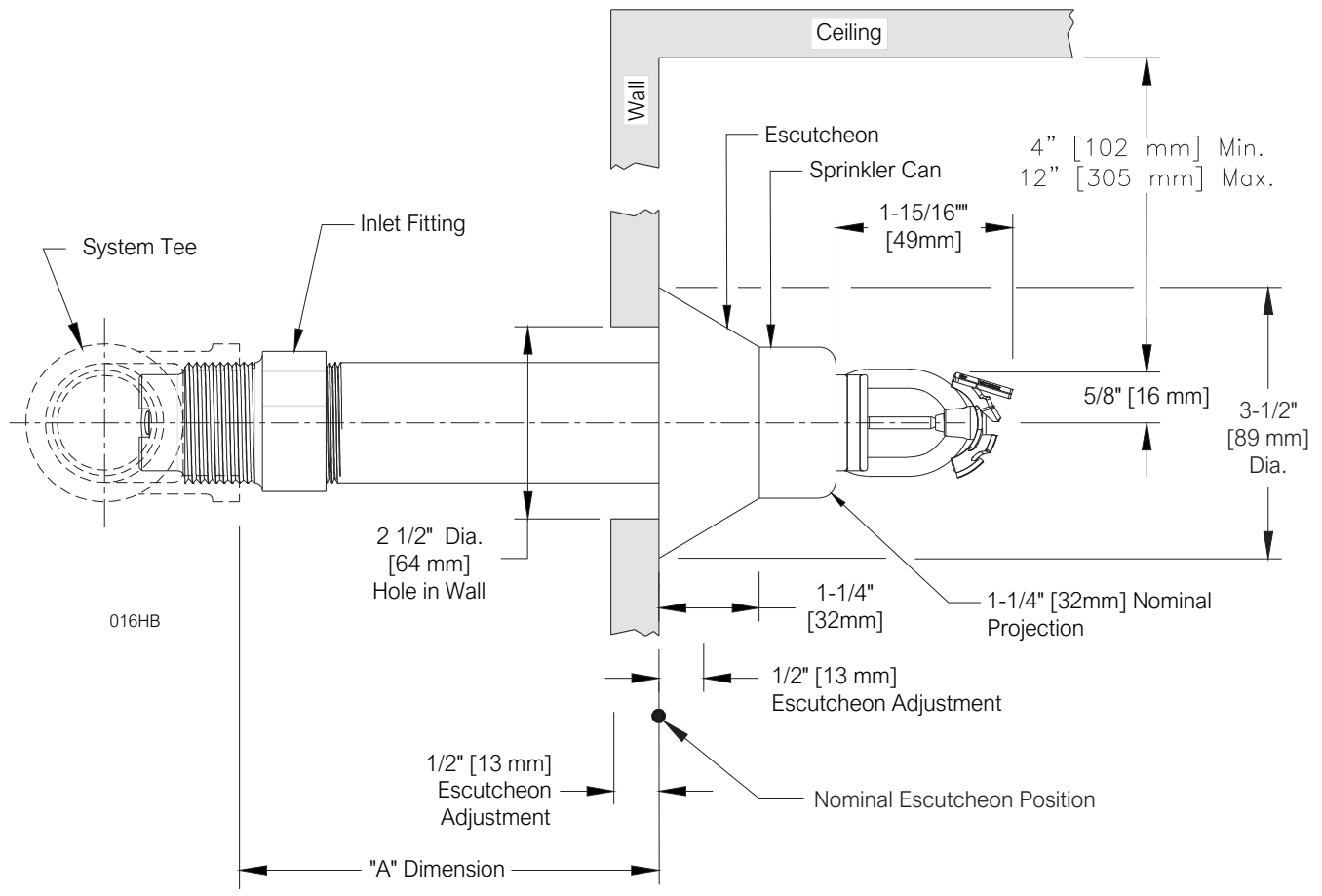

"A" Dimension: 3-1/2" to 36" (90mm to 900mm) in 1/4" (6mm) increments

Finish Combinations: HB Escutcheon	
Sprinkler	Escutcheon <sup>(2)(3)</sup>
Bronze	Chrome
Chrome	Chrome
White Polyester <sup>(1)</sup>	White Polyester
Black Polyester <sup>(1)</sup>	Black Polyester
Custom Color Polyester <sup>(1)</sup>	Custom Color Polyester
Electroless Nickel PTFE <sup>(1)</sup>	Stainless Steel

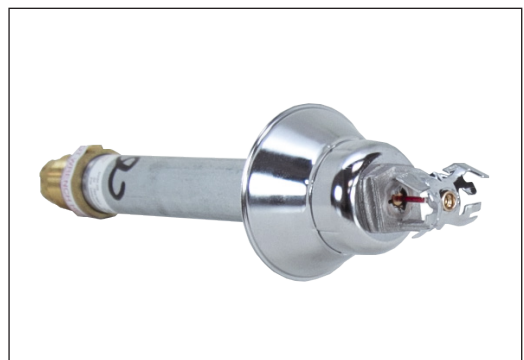

**Notes:**

1. UL Listed as Corrosion Resistant.
2. Escutcheons do not carry corrosion resistant listings.
3. Base material is cold rolled steel unless noted.

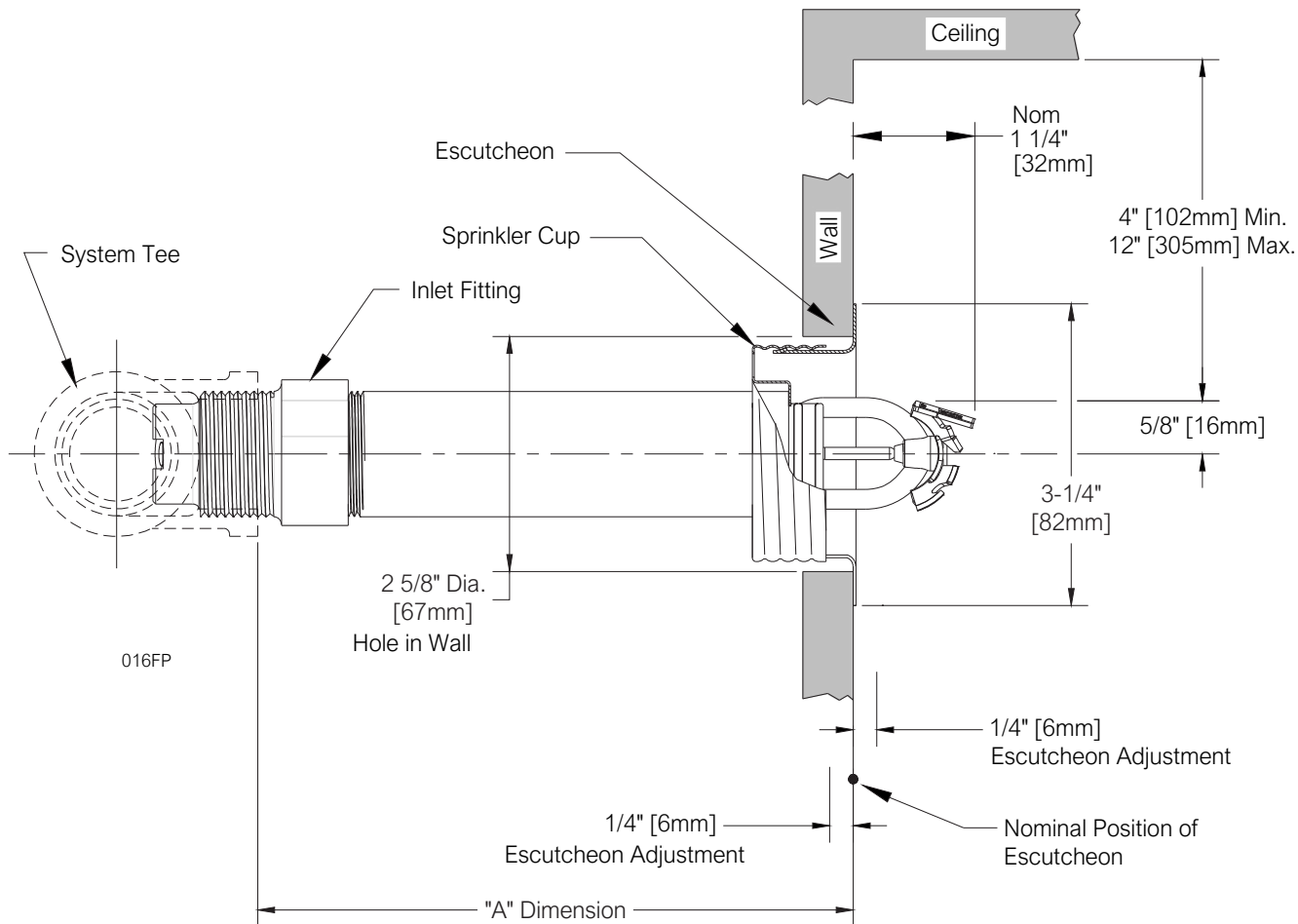

"A" Dimension: 3-1/2" to 48" (90mm to 1200mm) in 1/4" (6mm) increments

**Note:** Do not install the Model DH56 Dry Sprinkler with FP recessed escutcheon in locations where the pressure in the space behind the sprinkler is positive with respect to the pressure in the protected space. Ensure that openings in the sprinkler cup are unobstructed following installation.

Finish Combinations: FP Recessed Escutcheon	
Sprinkler <sup>(1)</sup>	Escutcheon <sup>(3)(4)</sup>
Bronze	Brass
Chrome	Chrome
White Polyester <sup>(2)</sup>	White Polyester
Black Polyester <sup>(2)</sup>	Black Polyester
Custom Color Polyester <sup>(2)</sup>	Custom Color Polyester
Electroless Nickel PTFE <sup>(2)</sup>	Stainless Steel



**Notes:**

1. Cup for FP Recessed is unfinished galvanized steel except electroless nickel PTFE sprinkler uses a stainless steel cup.
2. UL Listed as Corrosion Resistant.
3. Escutcheons do not carry corrosion resistant listings.
4. Base material is cold rolled steel unless noted.

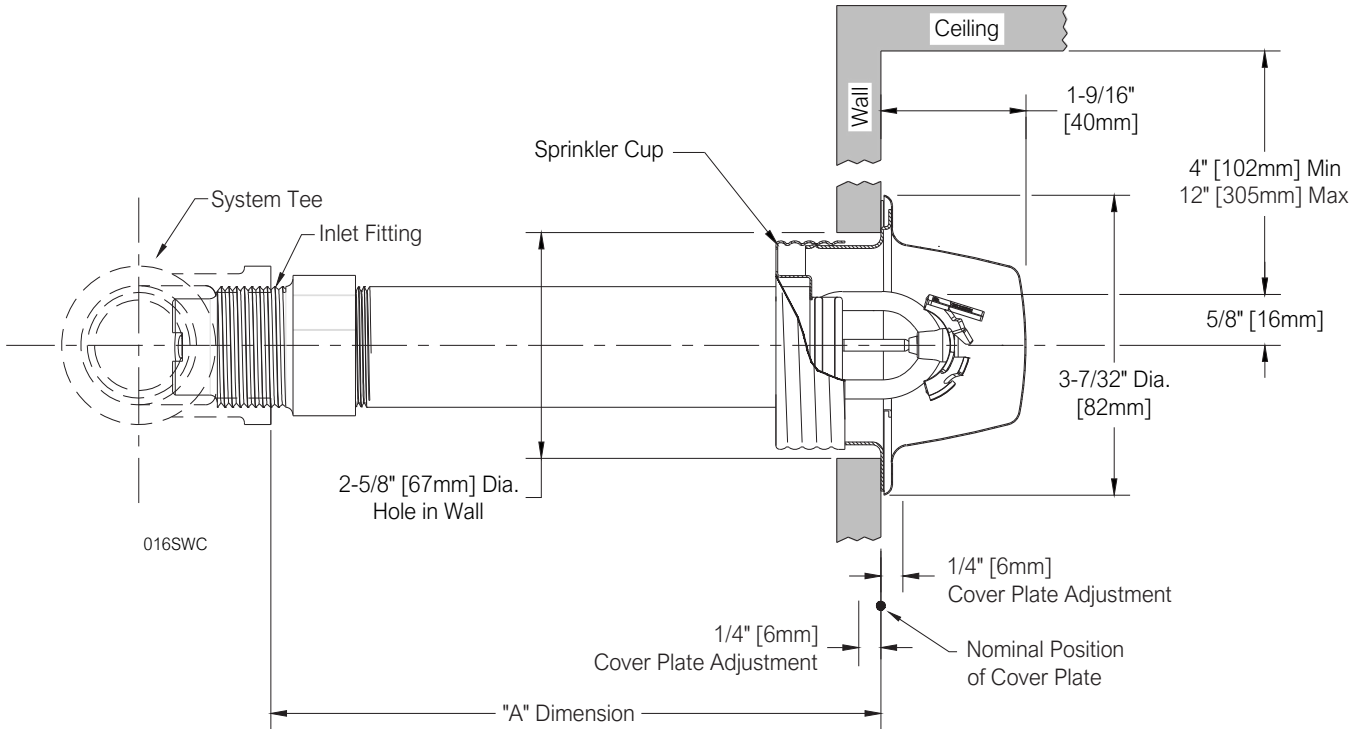

"A" Dimension: 3-1/2" to 48" (90mm to 1200mm) in 1/4" (6mm) increments

**Note:** Do not install the Model DH56 Dry Sprinkler with SWC cover plate in locations where the pressure in the space behind the sprinkler is positive with respect to the pressure in the protected space. Ensure that openings in the sprinkler cup are unobstructed following installation.

Finish Combinations: SWC Concealed Cover Plate	
Sprinkler <sup>(1)</sup>	Cover Plate <sup>(2)</sup>
Bronze	White Polyester
	Chrome Bright
	Chrome Dull
	Bright Brass
	Unfinished Bronze
	Custom Color

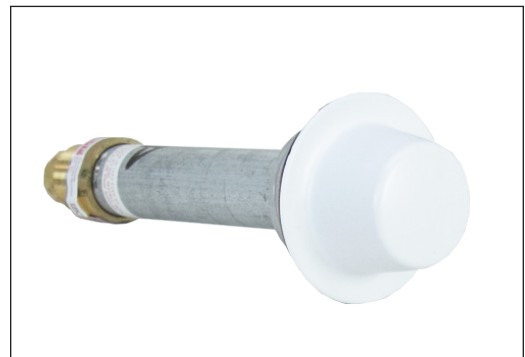

**Notes:**

1. Cup for SWC Concealed is unfinished galvanized steel.
2. Cover plates do not carry corrosion resistant listings.

MINIMUM EXPOSED BARREL LENGTH WHEN CONNECTED TO WET PIPE SPRINKLER SYSTEM

NOTE: STANDARD DRY PENDENT IS SHOWN, HOWEVER, MINIMUM EXPOSED BARREL LENGTH APPLIES TO ALL STYLES OF DRY SPRINKLERS CONNECTED TO A WET PIPE SYSTEM.

AMBIENT TEMPERATURE EXPOSED TO DISCHARGE END OF SPRINKLER*	EXPOSED BARREL AMBIENT TEMPERATURE		
	40°F/4°C	50°F/10°C	60°F/16°C
	EXPOSED MINIMUM BARREL LENGTH** (FACE OF FITTING TO TOP OF CEILING)***		
	IN. (MM)	IN. (MM)	IN. (MM)
40°F (4°C)	0	0	0
30°F (-1°C)	0	0	0
20°F (-7°C)	4 (100)	0	0
10°F (-12°C)	8 (200)	1 (25)	0
0°F (-18°C)	12 (300)	3 (75)	0
-10°F (-23°C)	14 (350)	4 (100)	1 (25)
-20°F (-29°C)	14 (350)	6 (150)	3 (75)
-30°F (-34°C)	16 (400)	8 (200)	4 (100)
-40°F (-40°C)	18 (450)	8 (200)	4 (100)
-50°F (-46°C)	20 (500)	10 (250)	6 (150)
-60°F (-51°C)	20 (500)	10 (250)	6 (150)

\* FOR AMBIENT TEMPERATURES EXPOSED TO THE DISCHARGE END OF THE SPRINKLER THAT OCCUR BETWEEN THE VALUES LISTED, USE THE NEXT COOLER TEMPERATURE.

\*\* THE MINIMUM EXPOSED BARREL LENGTH IS NOT THE SAME AS THE "A" DIMENSION. THE MINIMUM EXPOSED BARREL LENGTH IS BASED ON A PROPERLY SEALED PENETRATION WITH A MAXIMUM WIND VELOCITY ON THE EXPOSED SPRINKLER OF 30 MPH (48 KM/H). LONGER EXPOSED BARREL LENGTHS WILL HELP AVOID FREEZING OF THE WET PIPING WHERE HIGHER WIND VELOCITY IS EXPECTED.

\*\*\* THE MINIMUM EXPOSED BARREL LENGTH IS MEASURED FROM THE FACE OF THE FITTING TO THE INSIDE FACE OF THE INSULATION, WALL, OR CEILING LEADING TO THE COLD SPACE, WHICHEVER IS CLOSEST TO THE FITTING.

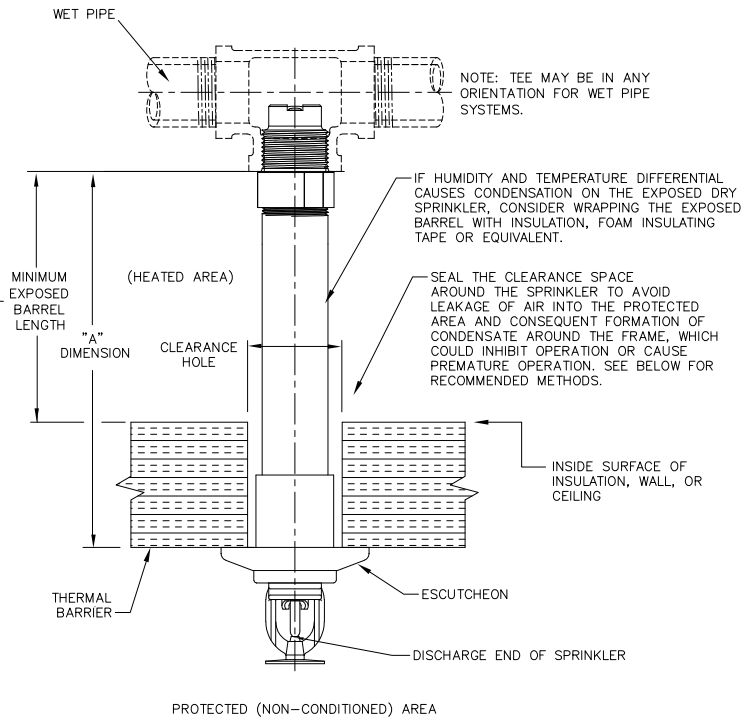

RECOMMENDED DRY SPRINKLER SEAL ARRANGEMENTS  
(DRY SPRINKLER WITH STANDARD ESCUTCHEON SHOWN)

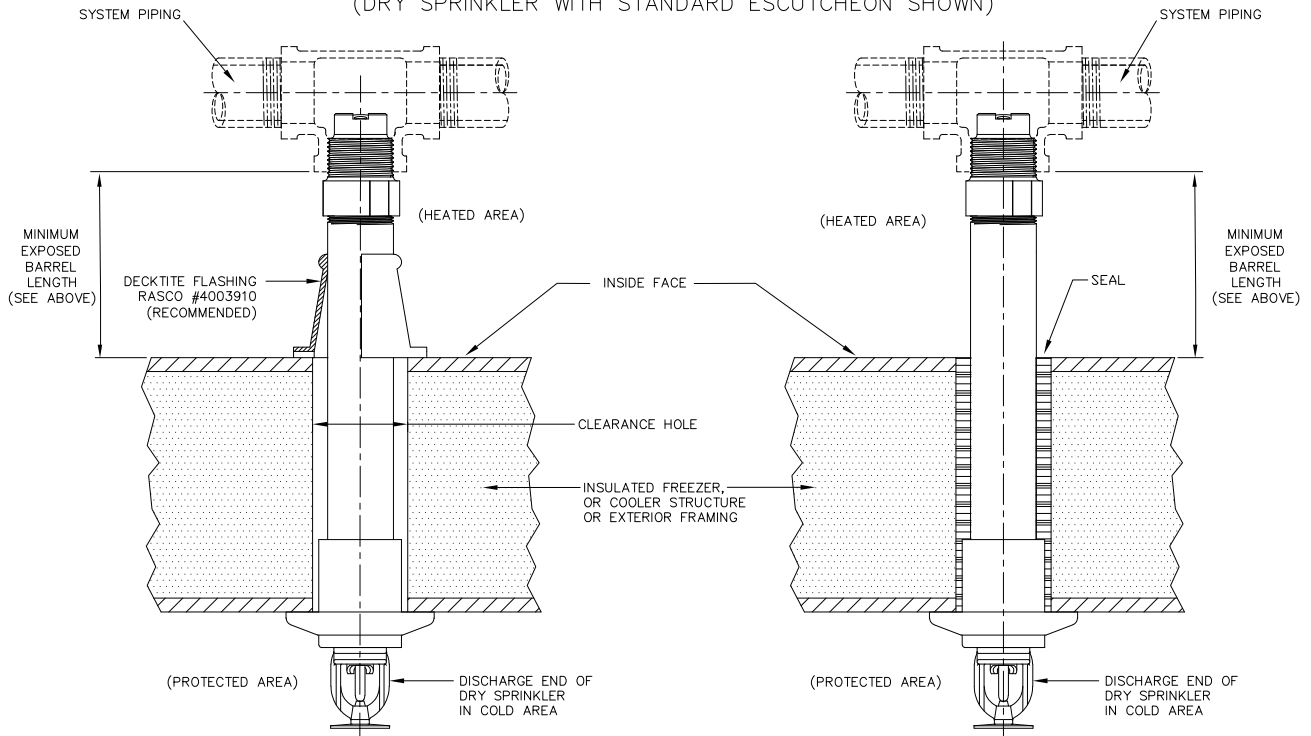

COMDRYDET11

### \*CAUTION\*

RELIABLE DRY SPRINKLERS MAY BE INSTALLED IN A LISTED CPVC SPRINKLER FITTING, ONLY UPON VERIFICATION THAT THE FITTING DOES NOT INTERFERE WITH THE SPRINKLER'S INLET.

Do not install dry sprinklers with standard inlets into CPVC fittings that have an internal obstruction; this will damage the sprinkler, the fitting, or both.

Short inlet ("PL") versions of Reliable dry sprinklers are available that may or may not be compatible with fittings having internal obstructions in existing installations. Sprinklers with the short inlet ("PL") should only be installed in CPVC fittings of wet-pipe systems.

In all cases, verify sprinkler and fitting dimensions prior to installation to avoid interference.

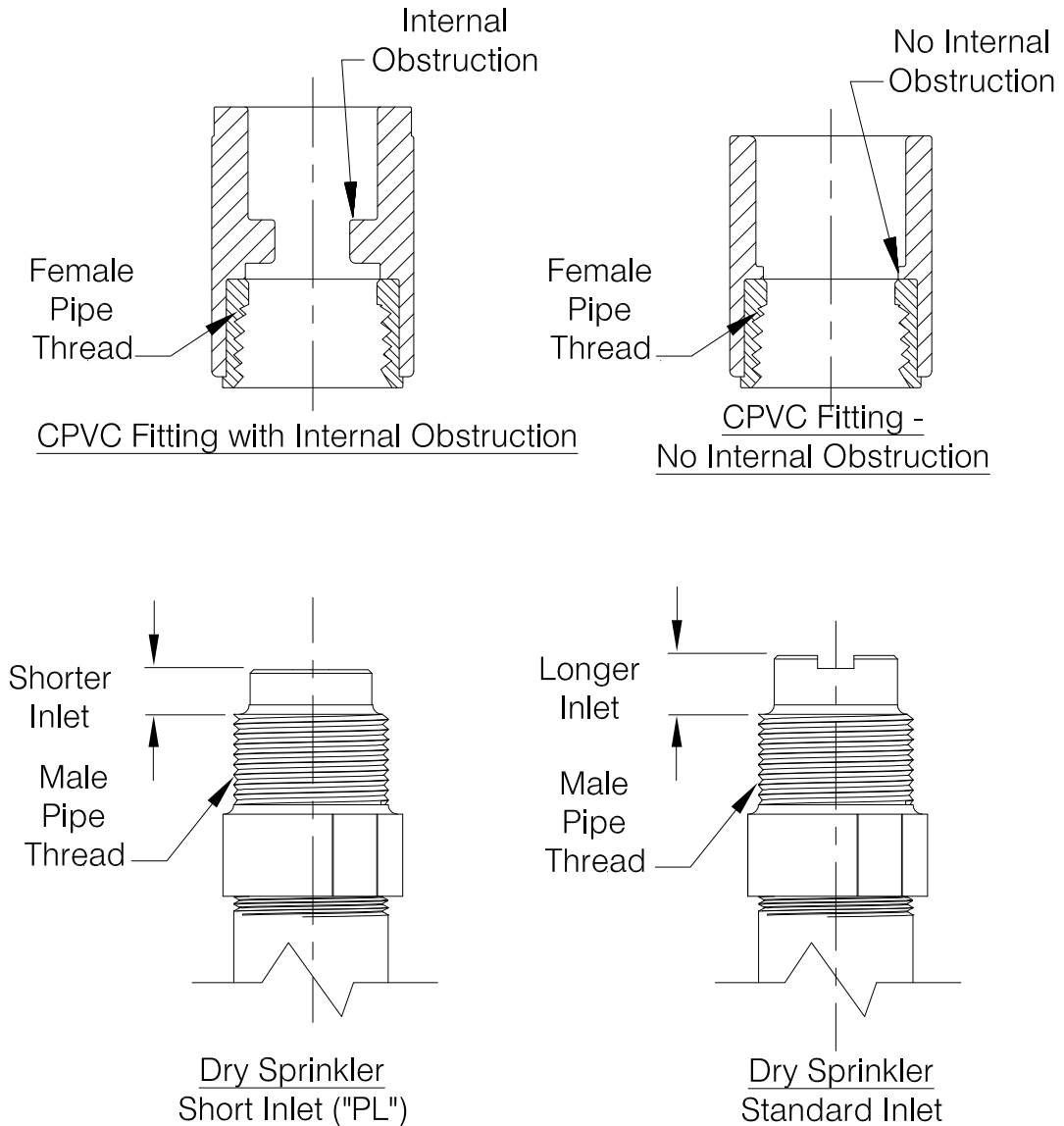

BE SURE TO ORDER THE CORRECT SPRINKLERS FOR YOUR APPLICATION



## Installation (General)

Dry sprinklers connected to wet pipe systems must be installed as indicated in Figure 6 and as required by NFPA 13 with the Exposed Minimum Barrel Length located in a heated area.

Reliable Model DH56 dry sidewall sprinklers may be installed in ductile or malleable cast iron threaded tees, or CPVC tees and adapters upon verification that the sprinkler inlet fitting does not interfere with the interior of the fitting (see Figure 7).

DO NOT install Reliable Model DH56 dry sidewall sprinklers into elbows or couplings, welded outlets, mechanical tees, or gasket sealed CPVC fittings.

### DH56 HSW with Standard Escutcheon

Cut a 2-1/8" (54mm) diameter hole in the wall as shown in Fig. 2. Apply a PTFE based sealant to the sprinkler threads before installing into the fitting. Use the Model F3R installation wrench (see Fig. 8) on the square boss to tighten the sprinkler until it is secured in the sprinkler fitting. Installation is completed by removing the orange glass bulb protector and sliding the escutcheon over the finished sleeve until tight to the finished surface.

### DH56 HSW with HB Escutcheon

Cut a 2-1/2" (64mm) diameter hole in the wall as shown in Fig. 3. Apply a PTFE based sealant to the sprinkler threads before installing into the fitting. Use the Model F3R installation wrench (see Fig. 8) on the square boss to tighten the sprinkler until it is secured in the sprinkler fitting. Installation is completed by removing the orange glass bulb protector and sliding the skirt over the finished sleeve until tight to the finished surface.

### DH56 HSW with FP Recessed Escutcheon

Cut a 2-5/8" (67mm) diameter hole in the wall as shown in Fig. 4. Apply a PTFE based sealant to the sprinkler threads before installing into the fitting. Use the Model F3R installation wrench (see Fig. 8) on the square boss to tighten the sprinkler until it is secured in the sprinkler fitting. Installation is completed by removing the orange glass bulb protector and pushing (or threading) the FP escutcheon into the threaded cup. Final adjustment is made by turning the FP escutcheon clockwise until the flange makes full contact with the wall surface.

### DH56 HSW SWC Concealed Cover Plate

Cut a 2-5/8" (67mm) diameter hole in the wall as shown in Fig. 5. Apply a PTFE based sealant to the sprinkler threads before installing into the fitting. Use the Model F3R installation wrench (see Fig. 8) on the square boss to tighten the sprinkler until it is secured in the sprinkler fitting. Installation is completed by removing the orange glass bulb protector and pushing (or threading) the SWC cover plate into the threaded cup. Final adjustment is made by turning the cover plate clockwise until the cover plate flange makes full contact with the finished surface.

#### Note:

1. The Model XLO2 installation wrench for FP Recessed and SWC Concealed installations has an open side to accommodate the sprinkler deflector and can only be inserted in one way (see Figure 8). Care must be taken not to damage the deflector during installation.
2. Do not over-tighten sprinklers into fittings. It is recommended that Reliable dry sprinklers be installed using the wrench referenced in this bulletin. A pipe wrench may also be used to install dry sprinklers provided that it only engages the outer tube (steel pipe) of the assembly. Note that a pipe wrench will impart a large amount of torque into the final assembly. This torque will need to be matched or exceeded to remove the sprinkler at a later date. A leak free joint can normally be obtained by installing the sprinkler to a minimum torque of 22 ft-lb (30 N-m) after applying an appropriate thread sealant.
3. Glass bulb sprinklers have orange bulb protectors to minimize bulb damage during shipping, handling, and installation. Reliable installation wrenches are designed to install sprinklers while bulb protectors are in place. REMOVE THE PROTECTORS AT THE TIME THE SPRINKLER SYSTEM IS PLACED INTO SERVICE. Removal of the protectors before this time may leave the glass bulb vulnerable to damage. Remove protectors by undoing the clasp by hand. DO NOT USE TOOLS TO REMOVE THE PROTECTORS.
4. Do not remove the wax fillet in the gap between the cup that supports the bulb and the wrenching boss.

XLO2 Installation Procedure

Figure 8

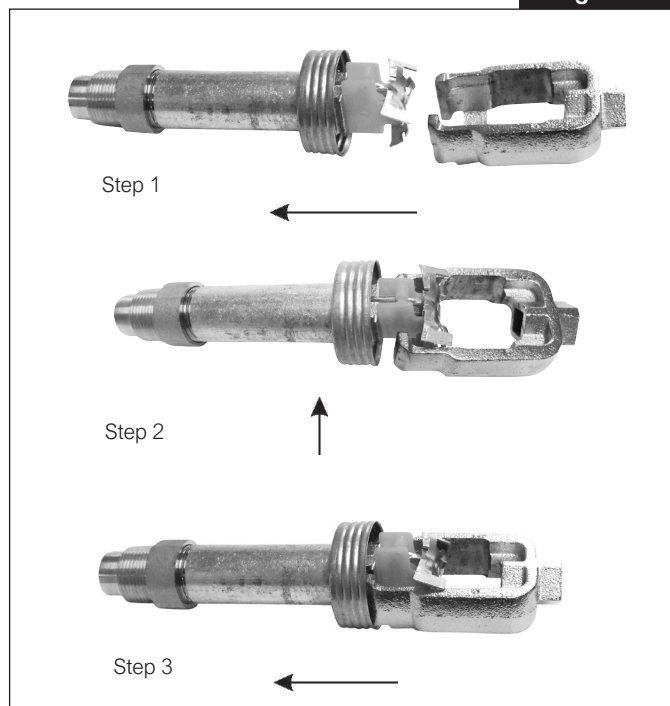

## Wrench Options



F3R Wrench (Standard & HB trims)



XLO2 Wrench (FP recessed and SWC trims)

## Maintenance

Reliable Model DH56 series sprinklers should be inspected and the sprinkler system maintained in accordance with NFPA 25, as well as the requirements of any Authorities Having Jurisdiction. Prior to installation, sprinklers should remain in the original cartons and packaging until used. This will minimize the potential for damage to sprinklers that could cause improper operation or non-operation.

Do not clean sprinklers with soap and water, ammonia liquid or any other cleaning fluids. Remove dust by gentle vacuuming without touching the sprinkler.

Replace any sprinkler which has been painted (other than factory applied). A stock of spare sprinklers should be maintained to allow quick replacement of damaged or operated sprinklers. Failure to properly maintain sprinklers may result in inadvertent operation or non-operation during a fire event.

## Guarantee

For the Reliable Automatic Sprinkler Co., Inc. guarantee, terms, and conditions, visit [www.reliablesprinkler.com](http://www.reliablesprinkler.com).

## Patents

US Patent No. 7,841,418

## Ordering Information

### Specify:

#### Sprinkler Type

- Model DH56 Dry Extended Coverage Horizontal Sidewall Sprinkler

#### Trim Style

- Standard Escutcheon
- HB Escutcheon
- FP Recessed Escutcheon
- SWC Cover Plate

#### Temperature Rating

- 155°F (68°C)
- 175°F (79°C)
- 200°F (93°C)

#### Finish

- See available combinations (depending on trim style) on pages 3-6

#### Length

- "A" Dimension (face of fitting to finished wall surface, in 1/4" [6mm] increments)

#### Installation Wrench

- Model F3R (Standard & HB trims)
- Model XLO2 (FP Recessed & SWC trims)